

Phased Array System Toolbox™

User's Guide

R2013b

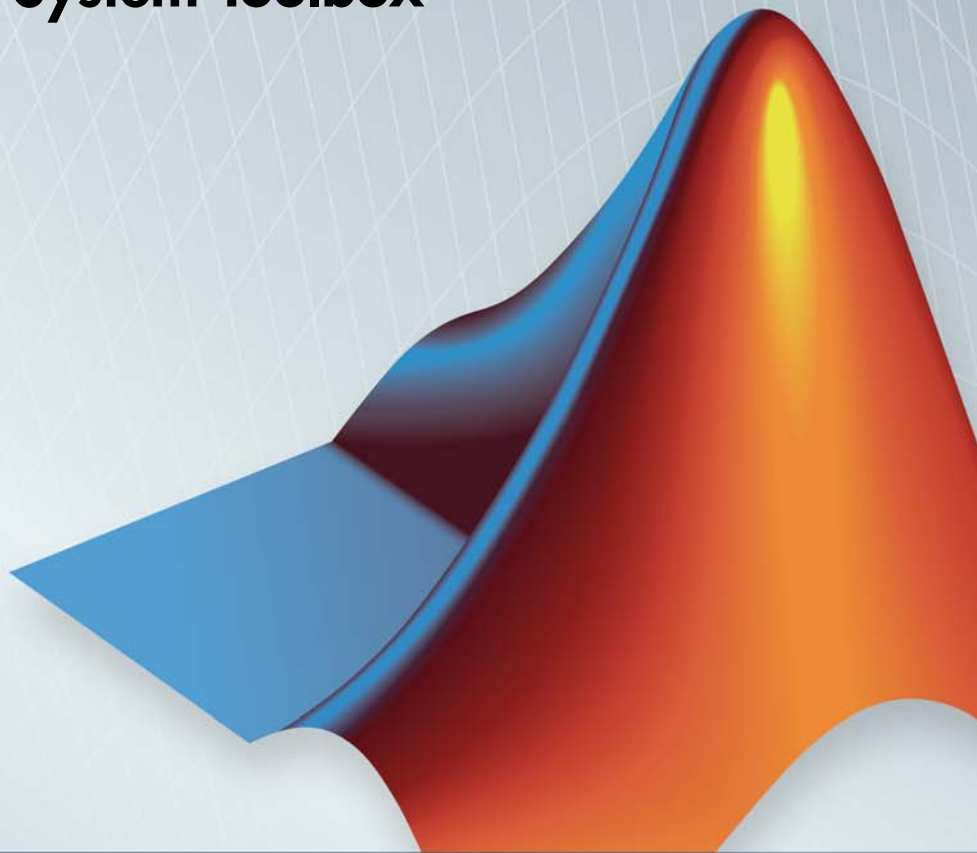

MATLAB®

How to Contact MathWorks



www.mathworks.com Web
comp.soft-sys.matlab Newsgroup
www.mathworks.com/contact_TS.html Technical Support



suggest@mathworks.com Product enhancement suggestions
bugs@mathworks.com Bug reports
doc@mathworks.com Documentation error reports
service@mathworks.com Order status, license renewals, passcodes
info@mathworks.com Sales, pricing, and general information



508-647-7000 (Phone)



508-647-7001 (Fax)



The MathWorks, Inc.
3 Apple Hill Drive
Natick, MA 01760-2098

For contact information about worldwide offices, see the MathWorks Web site.

Phased Array System Toolbox™ User's Guide

© COPYRIGHT 2011–2013 by The MathWorks, Inc.

The software described in this document is furnished under a license agreement. The software may be used or copied only under the terms of the license agreement. No part of this manual may be photocopied or reproduced in any form without prior written consent from The MathWorks, Inc.

FEDERAL ACQUISITION: This provision applies to all acquisitions of the Program and Documentation by, for, or through the federal government of the United States. By accepting delivery of the Program or Documentation, the government hereby agrees that this software or documentation qualifies as commercial computer software or commercial computer software documentation as such terms are used or defined in FAR 12.212, DFARS Part 227.72, and DFARS 252.227-7014. Accordingly, the terms and conditions of this Agreement and only those rights specified in this Agreement, shall pertain to and govern the use, modification, reproduction, release, performance, display, and disclosure of the Program and Documentation by the federal government (or other entity acquiring for or through the federal government) and shall supersede any conflicting contractual terms or conditions. If this License fails to meet the government's needs or is inconsistent in any respect with federal procurement law, the government agrees to return the Program and Documentation, unused, to The MathWorks, Inc.

Trademarks

MATLAB and Simulink are registered trademarks of The MathWorks, Inc. See www.mathworks.com/trademarks for a list of additional trademarks. Other product or brand names may be trademarks or registered trademarks of their respective holders.

Patents

MathWorks products are protected by one or more U.S. patents. Please see www.mathworks.com/patents for more information.

Revision History

April 2011	Online only	Revised for Version 1.0 (R2011a)
September 2011	Online only	Revised for Version 1.1 (R2011b)
March 2012	Online only	Revised for Version 1.2 (R2012a)
September 2012	Online only	Revised for Version 1.3 (R2012b)
March 2013	Online only	Revised for Version 2.0 (R2013a)
September 2013	Online only	Revised for Version 2.1 (R2013b)

Phased Arrays

Antenna and Microphone Elements

1

Isotropic Antenna Element	1-2
Support for Isotropic Antenna Elements	1-2
Backbaffled Isotropic Antenna	1-2
Element Response of Backbaffled Isotropic Antenna Element	1-4
Cosine Antenna Element	1-6
Support for Cosine Antenna Elements	1-6
Concentration of Cosine Response	1-7
Cosine Antenna Element Operating from 1 to 10 GHz	1-7
Custom Antenna Element	1-9
Support for Custom Antenna Elements	1-9
Antenna with Custom Radiation Pattern	1-10
Omnidirectional Microphone	1-11
Support for Omnidirectional Microphones	1-11
Backbaffled Omnidirectional Microphone	1-11
Custom Microphone Element	1-14
Support for Custom Microphone Elements	1-14

Array Geometries and Analysis

2

Uniform Linear Array	2-2
Support for Uniform Linear Arrays	2-2

Positions of Elements in Array	2-2
Identical Elements in Array	2-3
Response of Array Elements	2-4
Signal Delay Between Array Elements	2-4
Steering Vector	2-5
Array Response	2-6
Reception of Plane Wave Across Array	2-8
Microphone Array	2-9
Uniform Rectangular Array	2-11
Support for Uniform Rectangular Arrays	2-11
Uniform Rectangular Array with Isotropic Antenna Elements	2-11
Conformal Array	2-14
Support for Arrays with Custom Geometry	2-14
Uniform Circular Array	2-15
Custom Antenna Array	2-16
Subarrays Within Arrays	2-20
Definition of Subarrays	2-20
Benefits of Using Subarrays	2-20
Support for Subarrays Within Arrays	2-20
Rectangular Array Partitioned into Linear Subarrays	2-22
Linear Subarray Replicated to Form Rectangular Array ..	2-25
Linear Subarray Replicated in a Custom Grid	2-26

Signal Radiation and Collection

3

Signal Radiation	3-2
Support for Modeling Signal Radiation	3-2
Radiate Signal with Uniform Linear Array	3-2
Signal Collection	3-4
Support for Modeling Signal Collection	3-4
Narrowband Collector for Uniform Linear Array	3-5

Narrowband Collector for a Single Antenna Element	3-6
Wideband Signal Collection	3-7

Waveforms, Transmitter, and Receiver

4

Rectangular Pulse Waveforms	4-2
Definition of Rectangular Pulse Waveform	4-2
How to Create Rectangular Pulse Waveforms	4-2
Rectangular Waveform Plot	4-3
Pulses of Rectangular Waveform	4-4
Linear Frequency Modulated Pulse Waveforms	4-6
Benefits of Using Linear FM Pulse Waveform	4-6
Definition of Linear FM Pulse Waveform	4-6
How to Create Linear FM Pulse Waveforms	4-7
Configuration of Linear FM Pulse Waveform	4-8
Linear FM Pulse Waveform Plots	4-8
Ambiguity Function of Linear FM Waveform	4-10
Comparing Autocorrelation for Rectangular and Linear FM Waveforms	4-11
Stepped FM Pulse Waveforms	4-13
FMCW Waveforms	4-16
Benefits of Using FMCW Waveform	4-16
How to Create FMCW Waveforms	4-16
Double Triangular Sweep	4-17
Phase-Coded Waveforms	4-19
When to Use Phase-Coded Waveforms	4-19
How to Create Phase-Coded Waveforms	4-19
Basic Radar Using Phase-Coded Waveform	4-20
Waveforms with Staggered PRFs	4-24
When to Use Staggered PRFs	4-24
Linear FM Waveform with Staggered PRF	4-24

Transmitter	4-26
Transmitter Object	4-26
Phase Noise	4-28
Receiver Preamp	4-32
Operation of Receiver Preamp	4-32
Configuring Receiver Preamp	4-32
Model Receiver Effects on Sinusoidal Input	4-34
Model Coherent on Receive Behavior	4-35
Radar Equation	4-37
Radar Equation Theory	4-37
Link Budget Calculation Using the Radar Equation	4-39
Maximum Detectable Range for a Monostatic Radar	4-39
Output SNR at the Receiver in a Bistatic Radar	4-40

Beamforming

5

Conventional Beamforming	5-2
Uses for Beamformers	5-2
Support for Conventional Beamforming	5-2
Narrowband Phase Shift Beamformer with a ULA	5-2
Adaptive Beamforming	5-7
Benefits of Adaptive Beamforming	5-7
Support for Adaptive Beamforming	5-7
LCMV Beamformer	5-7
Wideband Beamforming	5-11
Support for Wideband Beamforming	5-11
Time-Delay Beamforming	5-11
Visualization of Wideband Beamformer Performance	5-13

Direction-of-Arrival (DOA) Estimation

6

Beamscan Direction-of-Arrival Estimation	6-2
Super-resolution DOA Estimation	6-4

Space-Time Adaptive Processing (STAP)

7

Angle-Doppler Response	7-2
Benefits of Visualizing Angle-Doppler Response	7-2
Angle-Doppler Response of a Stationary Target at a Stationary Array	7-2
Angle-Doppler Response of a Stationary Target Return at a Moving Array	7-5
Displaced Phase Center Antenna (DPCA) Pulse Canceller	7-9
When to Use the DPCA Pulse Canceller	7-9
Example: DPCA Pulse Canceller for Clutter Rejection ...	7-9
Adaptive Displaced Phase Center Antenna Pulse Canceller	7-14
When to Use the Adaptive DPCA Pulse Canceller	7-14
Example: Adaptive DPCA Pulse Canceller	7-14
Sample Matrix Inversion (SMI) Beamformer	7-21
When to Use the SMI Beamformer	7-21
Example: Sample Matrix Inversion (SMI) Beamformer ...	7-21

Neyman-Pearson Hypothesis Testing	8-2
Purpose of Hypothesis Testing	8-2
Support for Neyman-Pearson Hypothesis Testing	8-2
Threshold for Real-Valued Signal in White Gaussian Noise	8-3
Threshold for Two Pulses of Real-Valued Signal in White Gaussian Noise	8-4
Threshold for Complex-Valued Signals in Complex White Gaussian Noise	8-5
 Receiver Operating Characteristic (ROC) Curves	 8-6
 Matched Filtering	 8-11
Reasons for Using Matched Filtering	8-11
Support for Matched Filtering	8-11
Matched Filtering of Linear FM Waveform	8-11
Matched Filtering to Improve SNR for Target Detection ..	8-13
 Stretch Processing	 8-17
Reasons for Using Stretch Processing	8-17
Support for Stretch Processing	8-17
Stretch Processing Procedure	8-17
 FMCW Range Estimation	 8-19
 Range-Doppler Response	 8-21
Benefits of Producing Range-Doppler Response	8-21
Support for Range-Doppler Processing	8-21
Range-Speed Response Pattern of Target	8-23
 Constant False-Alarm Rate (CFAR) Detectors	 8-27
Reasons for Using CFAR Detectors	8-27
Cell-Averaging CFAR Detector	8-28
Testing CFAR Detector Adaption to Noisy Input Data ...	8-30
Extensions of Cell-Averaging CFAR Detector	8-31
Detection Probability for CFAR Detector	8-32

Environment and Target Models

9

Free Space Path Loss	9-2
Support for Modeling Propagation in Free Space	9-2
Free Space Path Loss in Decibels	9-3
Propagation of a Linear FM Pulse Waveform to and from a Target	9-3
One-Way and Two-Way Propagation	9-4
Propagation from Stationary Radar to Moving Target	9-6
Radar Target	9-9
Clutter Modeling	9-13
Surface Clutter Overview	9-13
Approaches for Clutter Simulation or Analysis	9-13
Considerations for Setting Up a Constant Gamma Clutter Simulation	9-14
Related Examples	9-15
Barrage Jammer	9-17
Support for Modeling Barrage Jammer	9-17
Model Real and Imaginary Parts of Barrage Jammer Output	9-17
Model Effect of Barrage Jammer on Target Echo	9-18

Coordinate Systems and Motion Modeling

10

Rectangular Coordinates	10-2
Definitions of Coordinates	10-2
Notation for Vectors and Points	10-3
Orthogonal Basis and Euclidean Norm	10-3
Orientation of Coordinate Axes	10-4
Rotations and Rotation Matrices	10-7
Spherical Coordinates	10-16
Support for Spherical Coordinates	10-16

Azimuth and Elevation Angles	10-16
Phi and Theta Angles	10-17
U and V Coordinates	10-18
Conversion Between Rectangular and Spherical Coordinates	10-19
Broadside Angle	10-20
Global and Local Coordinate Systems	10-23
Global Coordinate System	10-23
Local Coordinate System	10-25
Converting Between Global and Local Coordinate Systems	10-28
Motion Modeling in Phased Array Systems	10-30
Support for Motion Modeling	10-30
Platform Motion with Constant Velocity	10-31
Platform Motion with Nonconstant Velocity	10-32
Track Range and Angle Changes Between Platforms	10-33
Doppler Shift and Pulse-Doppler Processing	10-35
Support for Pulse-Doppler Processing	10-35
Converting Speed to Doppler Shift	10-35
Converting Doppler Shift to Speed	10-36
Pulse-Doppler Processing of Slow-Time Data	10-36

Using Polarization

11

Polarized Fields	11-2
Introduction to Polarization	11-2
Linear and Circular Polarization	11-4
Elliptic Polarization	11-9
Linear and Circular Polarization Bases	11-14
Sources of Polarized Fields	11-18
Scattering Cross-Section Matrix	11-26
Polarization Loss Due to Field and Receiver Mismatch ...	11-32
Polarization Example	11-34

12

About Code Generation 12-2

 Code Generation Use and Benefits 12-2

 Limitations Specific to Phased Array System Toolbox 12-4

 General Limitations 12-6

 Limitations for System Objects that Require Dynamic
 Memory Allocation 12-12

Estimating Directions of Arrival 12-13

Making System Objects Persistent 12-16

Functions Supported for C/C++ Code Generation 12-19

**System Objects Supported for C/C++ Code
 Generation** 12-23

Define New System Objects

13

Define Basic System Objects 13-2

Change Number of Step Inputs or Outputs 13-4

Validate Property and Input Values 13-7

**Initialize Properties and Setup One-Time
 Calculations** 13-10

Set Property Values at Construction Time 13-13

Reset Algorithm State 13-16

Define Property Attributes	13-18
Hide Inactive Properties	13-22
Limit Property Values to Finite String Set	13-24
Process Tuned Properties	13-27
Release System Object Resources	13-29
Define Composite System Objects	13-31
Define Finite Source Objects	13-35
Save System Object	13-37
Load System Object	13-40
Clone System Object	13-43
Methods Timing	13-44
Setup Method Call Sequence	13-44
Step Method Call Sequence	13-45
Reset Method Call Sequence	13-45
Release Method Call Sequence	13-46
System Object Input Arguments and ~ in Code	
Examples	13-47
What Are Mixin Classes?	13-48

Phased Arrays

- Chapter 1, “Antenna and Microphone Elements”
- Chapter 2, “Array Geometries and Analysis”
- Chapter 3, “Signal Radiation and Collection”

Antenna and Microphone Elements

- “Isotropic Antenna Element” on page 1-2
- “Cosine Antenna Element” on page 1-6
- “Custom Antenna Element” on page 1-9
- “Omnidirectional Microphone” on page 1-11
- “Custom Microphone Element” on page 1-14

Isotropic Antenna Element

In this section...
“Support for Isotropic Antenna Elements” on page 1-2
“Backbaffled Isotropic Antenna” on page 1-2
“Element Response of Backbaffled Isotropic Antenna Element” on page 1-4

Support for Isotropic Antenna Elements

An isotropic antenna element radiates equal power in all nonbaffled directions. To construct an isotropic antenna, use `phased.IsotropicAntennaElement`. When you use this object, you must specify these aspects of the antenna:

- Operating frequency range of the antenna
- Whether the response of the antenna is baffled at azimuth angles outside the interval $[-90,90]$

You can find your isotropic antenna element’s voltage response at specific frequencies and angles using the antenna element’s `step` method.

Backbaffled Isotropic Antenna

This example shows how to construct a backbaffled isotropic antenna element with a uniform frequency response over azimuth angles from $[-180,180]$ degrees and elevation angles from $[-90,90]$ degrees. The antenna operates between 300 megahertz (MHz) and 1 gigahertz (GHz). Plot the antenna response at 1 GHz.

```
ha = phased.IsotropicAntennaElement(...  
    'FrequencyRange',[3e8 1e9],'BackBaffled',false)  
plotResponse(ha,1e9,'RespCut','3D','Format','Polar',...  
    'Unit','pow');
```

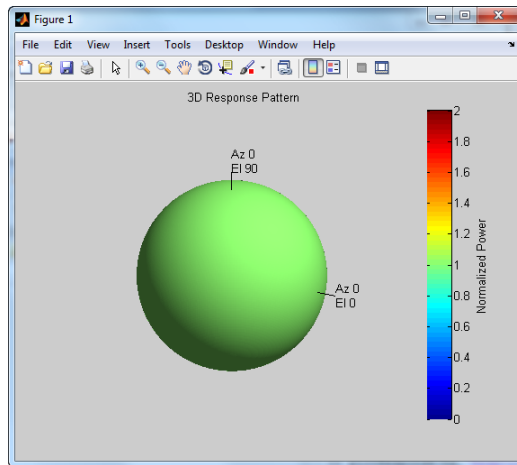

`plotResponse` is a method of `phased.IsotropicAntennaElement`. By default, `plotResponse` plots the response of the antenna element in decibels (dB) at zero degrees elevation.

```
figure;
plotResponse(ha,1e9);
```

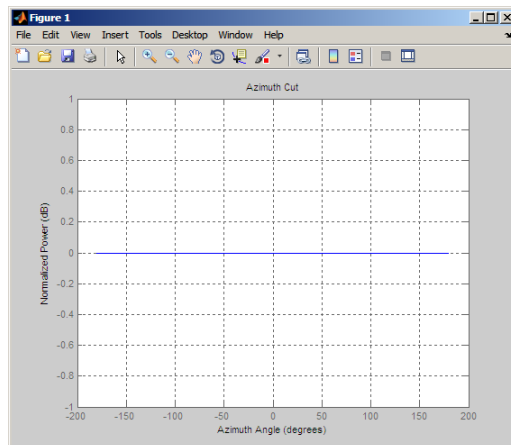

Setting the `BackBaffled` property to `true` limits the response to azimuth angles in the interval $[-90,90]$.

```

ha.BackBaffled=true;
figure;
plotResponse(ha,1e9,'RespCut','3D','Format','Polar',...
    'Unit','pow');

```

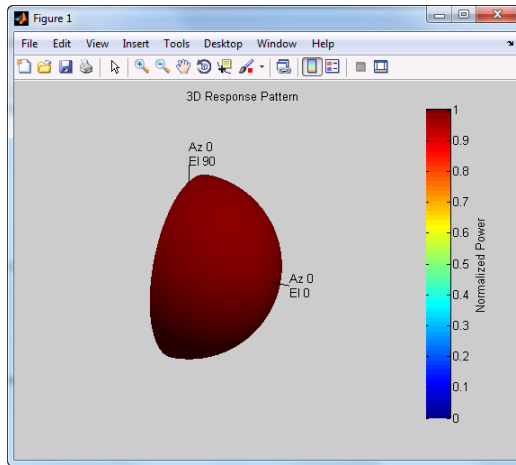

Element Response of Backbaffled Isotropic Antenna Element

This example shows how to design a backbaffled isotropic antenna element and obtain the response of that element.

Construct an isotropic antenna element to operate in the IEEE® X band between 8 and 12 GHz. Backbaffle the response of the antenna. Obtain your antenna element's response at 4 GHz intervals between 6 and 14 GHz and at azimuth angles between -100 and 100 in 50-degree increments.

```

ha = phased.IsotropicAntennaElement(...
    'FrequencyRange',[8e9 12e9],'BackBaffled',true)
respfreqs = 6e9:4e9:14e9;
respazangles = -100:50:100;
anresp = step(ha,respfreqs,respazangles)

```

The antenna response in `anresp` is a matrix whose row dimension equals the number of azimuth angles in `respazangles` and whose column dimension equals the number of frequencies in `respfreqs`.

The response voltage in the first two and last two columns of `anresp` is zero because those columns contain the antenna response at 6 and 14 GHz respectively. These frequencies are not included in the antenna's operating frequency range.

Similarly, the first and last rows of `anresp` contain all zeros because the `BackBaffled` property is set to `true`. The first and last row contain the antenna's response at azimuth angles outside of $[-90,90]$.

To obtain the antenna response at nonzero elevation angles, input the angles to `step` as a 2-by-`M` matrix where each column is an angle in the form `[azimuth;elevation]`.

```
release(ha)
respangles = -90:45:90;
respangles = [respazangles; respangles];
anresp = step(ha,respfreqs,respangles)
```

Note that `anresp(1,2)` and `anresp(5,2)` represent the antenna voltage response at the azimuth-elevation pairs $(-100,-90)$ and $(100,90)$. Because the elevation angles are equal to ± 90 degrees, these responses are equal to one even though the `BackBaffled` property is set to `true`. Thus, the resulting elevation cut degenerates into a point.

Cosine Antenna Element

In this section...

“Support for Cosine Antenna Elements” on page 1-6

“Concentration of Cosine Response” on page 1-7

“Cosine Antenna Element Operating from 1 to 10 GHz” on page 1-7

Support for Cosine Antenna Elements

The phased.CosineAntennaElement object models an antenna element whose response is cosine raised to a specified power in the azimuth and elevation directions.

The *cosine response*, or *cosine pattern*, is given by:

$$P(az, el) = \cos^m(az) \cos^n(el)$$

In this expression:

- az is the azimuth angle.
- el is the elevation angle.
- The exponents m and n are real numbers greater than or equal to 1.

The response is defined for azimuth and elevation angles between -90 and 90 degrees, inclusive. There is no response at the back of a cosine antenna. The cosine response pattern achieves a maximum value of 1 at 0 degrees azimuth and elevation. Raising the response pattern to powers greater than one concentrates the response in azimuth or elevation.

When you use the cosine antenna element, you specify the exponent of the cosine pattern and the operating frequency range of the antenna.

Concentration of Cosine Response

This example shows how to visualize the effect of concentrating the response. The example computes and plots the cosine response with powers equal to 1 and 2 for a single angle between -90 and 90 degrees.

```
theta = -90:.01:90;
Cos1 = cosd(theta);
Cos2 = Cos1.^2;
plot(theta,Cos1); hold on;
plot(theta,Cos2,'r');
legend('Exponent = 1','Exponent = 2','location','northeast');
xlabel('Degrees'); ylabel('Response');
```

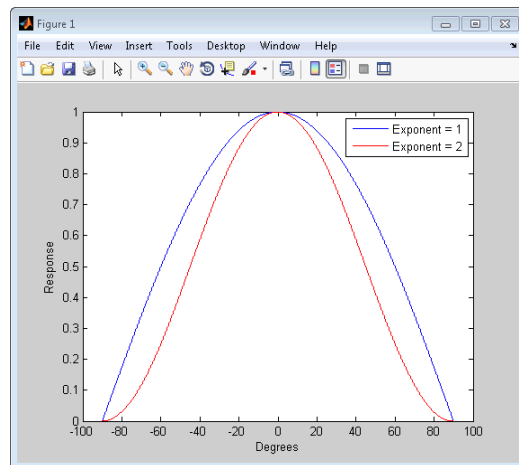

Cosine Antenna Element Operating from 1 to 10 GHz

This example shows how to construct an antenna with a cosine squared response in both azimuth and elevation and plot the antenna response. The operating frequency range of the antenna is from 1 to 10 GHz.

```
hcos = phased.CosineAntennaElement(...
    'FrequencyRange',[1e9 1e10],'CosinePower',[2 2])
plotResponse(hcos,5e9,'RespCut','3D','Format','Polar');
```

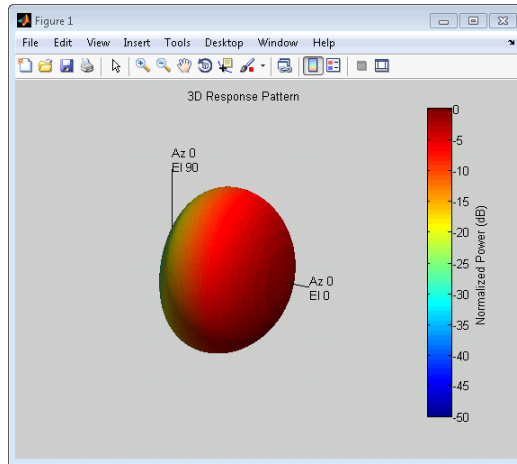

Custom Antenna Element

In this section...
“Support for Custom Antenna Elements” on page 1-9
“Antenna with Custom Radiation Pattern” on page 1-10

Support for Custom Antenna Elements

The phased.CustomAntennaElement object enables you to model a custom antenna element. When you use phased.CustomAntennaElement, you must specify these aspects of the antenna:

- Operating frequency vector for the antenna element
- Frequency response of the element at the frequencies in the operating frequency vector
- Azimuth angles and elevation angles where the custom response is evaluated
- Magnitude radiation pattern. This pattern shows the spatial response of the antenna at the azimuth and elevation angles you specify.

Tip You can import a radiation pattern that uses u/v coordinates or ϕ/θ angles, instead of azimuth/elevation angles. To use such a pattern with phased.CustomAntennaElement, first convert your pattern to azimuth/elevation form. Use uv2azelpat or phitheta2azelpat to do the conversion. For an example, see Antenna Array Analysis with Custom Radiation Pattern.

For your custom antenna element, the antenna response (the output of step) depends on the frequency response and radiation pattern. Specifically, the frequency and spatial responses are interpolated separately using nearest-neighbor interpolation and then multiplied together to produce the total response. To avoid interpolation errors, the range of azimuth angles should include ± 180 degrees and the range of elevation angles should include ± 90 degrees.

Antenna with Custom Radiation Pattern

This example shows how to construct a custom antenna element object. The radiation pattern is constant over each azimuth angle and has a cosine pattern for the elevation angles.

```
Az = -180:90:180;
El = -90:45:90;
Elresp = cosd(El);
ha = phased.CustomAntennaElement('AzimuthAngles',Az,...
    'ElevationAngles',El,...
    'RadiationPattern',repmat(Elresp',1,numel(Az)));
ha.RadiationPattern
```

Use the `step` method to calculate the antenna response at the azimuth-elevation pairs `[-30 0; -45 0]`; for a frequency of 500 MHz.

```
ANG = [-30 0; -45 0];
resp = step(ha,5e8,ANG)
```

The following illustrates the nearest-neighbor interpolation method used to find the antenna voltage response.

```
G = interp2(deg2rad(ha.AzimuthAngles),...
    deg2rad(ha.ElevationAngles),...
    db2mag(ha.RadiationPattern),...
    deg2rad(ANG(1,:))', deg2rad(ANG(2,:))', 'nearest', 0);
H = interp1(ha.FrequencyVector,...
    db2mag(ha.FrequencyResponse),5e8, 'nearest', 0);
antresp = H.*G
```

Compare the value of `antresp` to the output of the `step` method.

Omnidirectional Microphone

In this section...

“Support for Omnidirectional Microphones” on page 1-11

“Backbaffled Omnidirectional Microphone” on page 1-11

Support for Omnidirectional Microphones

An omnidirectional microphone has a response which is equal to one in all nonbaffled directions. The `phased.OmnidirectionalMicrophoneElement` object enables you to model an omnidirectional microphone. When you use this object, you must specify these aspects of the microphone:

- Operating frequency range of the microphone
- Whether the response of the microphone is baffled at azimuth angles outside the interval $[-90,90]$

Backbaffled Omnidirectional Microphone

Construct an omnidirectional microphone element using the human audible frequency range of 20 to 20,000 Hz. Baffle the microphone response for azimuth angles outside of ± 90 degrees. Plot the microphone’s power response at 1000 Hz in polar form.

```
hmic = phased.OmnidirectionalMicrophoneElement(...  
    'BackBaffled',true,'FrequencyRange',[20 20e3]);  
plotResponse(hmic,1e3,'RespCut','3D','Format','Polar',...  
    'Unit','pow');
```

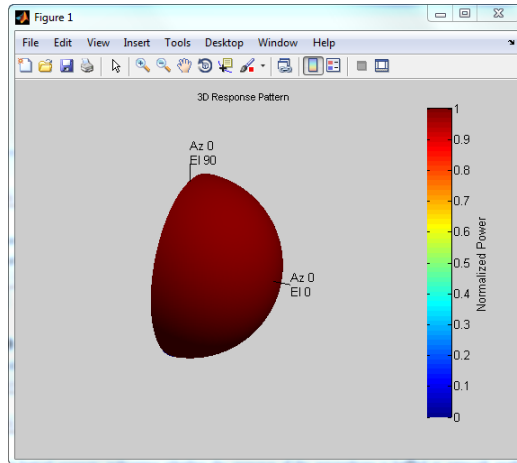

In many applications, you sometimes need to examine the microphone's directionality, or polar pattern. To do so, set the `RespCut` argument of `plotResponse` to one of the 2-D options and set the `Format` argument to 'Polar'. The 2-D options for the cut of the response are 'Az' (default), and 'El'.

```
% Using the default azimuth cut  
figure;  
plotResponse(hmic,1e3,'Format','Polar');
```

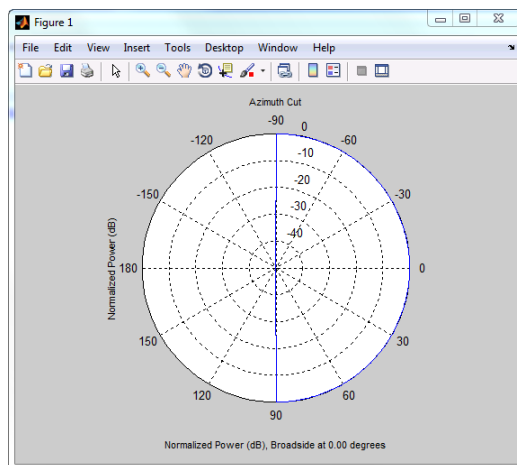

Use `step` to obtain the microphone's magnitude response at the specified azimuth angles and frequencies. The elevation angles are 0 degrees. Note the response is one at all azimuth angles and frequencies as expected.

```
freq = 100:250:1e3;  
ang = -90:30:90;  
micresp = step(hmic,freq,ang)
```

Custom Microphone Element

Support for Custom Microphone Elements

You can model a microphone with your custom response using `phased.CustomMicrophoneElement`. When you use `phased.CustomMicrophoneElement`, you must specify these aspects of the microphone:

- Frequencies where you specify your response
- Frequency response corresponding to the specified frequencies
- Frequencies and angles at which the microphone's polar pattern is measured.
- Magnitude response of the microphone.
- “Microphone Array” on page 2-9

Related Examples

Array Geometries and Analysis

- “Uniform Linear Array” on page 2-2
- “Microphone Array” on page 2-9
- “Uniform Rectangular Array” on page 2-11
- “Conformal Array” on page 2-14
- “Subarrays Within Arrays” on page 2-20

Uniform Linear Array

In this section...
“Support for Uniform Linear Arrays” on page 2-2
“Positions of Elements in Array” on page 2-2
“Identical Elements in Array” on page 2-3
“Response of Array Elements” on page 2-4
“Signal Delay Between Array Elements” on page 2-4
“Steering Vector” on page 2-5
“Array Response” on page 2-6
“Reception of Plane Wave Across Array” on page 2-8

Support for Uniform Linear Arrays

The uniform linear array (ULA) arranges identical sensor elements along a line in space with uniform spacing. You can design a ULA with `phased.ULA`. When you use this object, you must specify these aspects of the array:

- Sensor elements of the array
- Spacing between array elements
- Number of elements in the array

Positions of Elements in Array

Create and view a ULA with two isotropic antenna elements separated by 0.5 meters:

```
hula = phased.ULA('NumElements',2,'ElementSpacing',0.5);  
viewArray(hula);
```

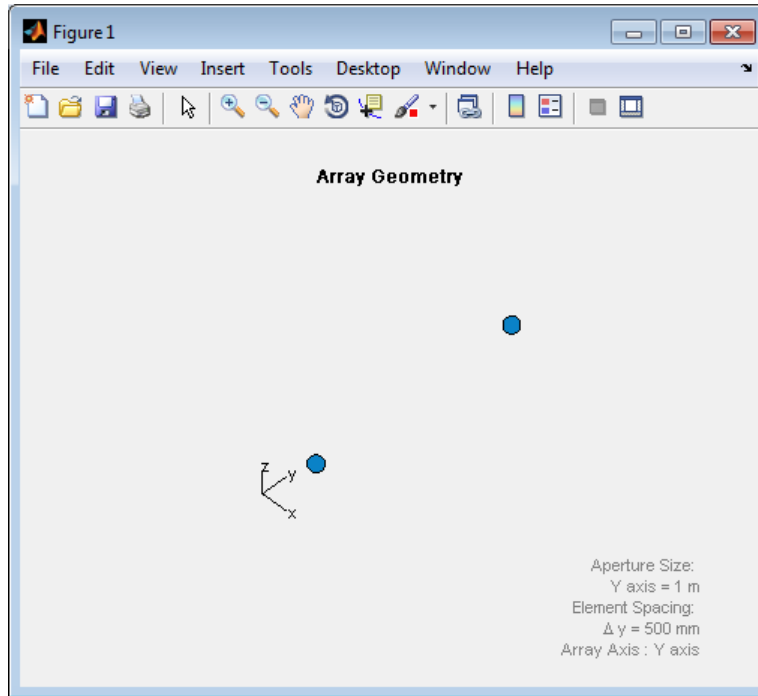
You can return the coordinates of the array sensor elements in the form $[x;y;z]$ by using the `getElementPosition` method. See “Rectangular Coordinates” on page 10-2 for toolbox conventions.

```
sensorpos = getElementPosition(hula);
```

`sensorpos` is a 3-by-2 matrix with each column representing the position of a sensor element. Note that the y -axis is the array axis. The positive x -axis is the array look direction (0 degrees broadside). The elements are symmetric with the respect to the phase center of the array.

Identical Elements in Array

The default element for a ULA is the `phased.IsotropicAntennaElement` object. You can specify an alternative element by changing the `Element` property.

Response of Array Elements

To obtain the responses of your array elements, use the array's `step` method.

```
% Construct antenna for the array elements
hant = phased.IsotropicAntennaElement(...
    'FrequencyRange',[3e8 1e9]);
hula = phased.ULA('NumElements',2,'ElementSpacing',0.5,...
    'Element',hant);
% Obtain element responses at 1 GHz
freq = 1e9;
% for azimuth angles from -180:180
azangles = -180:180;
% elementresponses
elementresponses = step(hula,1e9,azangles);
```

`elementresponses` is a 2-by-361 matrix where each column contains the element responses for the 361 azimuth angles. Because the elements of the ULA are isotropic antennas, `elementresponses` is a matrix of ones.

Signal Delay Between Array Elements

To determine the signal delay in seconds between array elements, use `phased.ElementDelay`. The incident waveform is assumed to satisfy the far-field assumption.

The following example computes the delay between elements of a 4-element ULA for a signal incident on the array from -90 degrees azimuth and zero degrees elevation. The delays are computed with respect to the phase center of the array. By default, `phased.ElementDelay` assumes that the incident waveform is an electromagnetic wave propagating at the speed of light.

```
% Construct 4-element ULA using value-only syntax
hula = phased.ULA(4);
hdelay = phased.ElementDelay('SensorArray',hula);
tau = step(hdelay,[-90;0]);
```

`tau` is a 4-by-1 vector of delays with respect to the phase center of the array, which is the origin of the local coordinate system $[0;0;0]$. See “Global and Local Coordinate Systems” on page 10-23 for a description of global and local coordinate systems. Negative delays indicate that the signal arrives at an

element before reaching the phase center of the array. Because the waveform arrives from an azimuth angle of -90 degrees, the signal impinges on the first and second elements of the ULA before it reaches the phase center resulting in negative delays.

If the signal is incident on the array at 0 degrees broadside from a far-field source, the signal illuminates all elements of the array simultaneously resulting in zero delay.

```
tau = step(hdelay,[0;0]);
```

If the incident signal is an acoustic pressure waveform propagating at the speed of sound, you can calculate the element delays by specifying the `PropagationSpeed` property.

```
hdelay = phased.ElementDelay('SensorArray',hula,...
    'PropagationSpeed',340);
tau = step(hdelay,[90;0]);
```

In the preceding code, the propagation speed is set to 340 m/s, which is the approximate speed of sound at sea level.

Steering Vector

The *steering vector* represents the relative phase shifts for the incident far-field waveform across the array elements. You can determine these phase shifts with the `phased.SteeringVector` object.

For a single carrier frequency, the steering vector for a ULA consisting of N elements is:

$$\begin{pmatrix} e^{-j2\pi f\tau_1} \\ e^{-j2\pi f\tau_2} \\ e^{-j2\pi f\tau_3} \\ \cdot \\ \cdot \\ \cdot \\ e^{-j2\pi f\tau_N} \end{pmatrix}$$

where τ_n denotes the time delay relative to the array phase center at the n -th array element.

Compute the steering vector for a 4-element ULA with an operating frequency of 1 GHz. Assume that the waveform is incident on the array from 45 degrees azimuth and 10 degrees elevation.

```
hula = phased.ULA(4);  
hsv = phased.SteeringVector('SensorArray',hula);  
sv = step(hsv,1e9,[45; 10]);
```

You can obtain the steering vector with the following equivalent code.

```
hdelay = phased.ElementDelay('SensorArray',hula);  
tau = step(hdelay,[45;10]);  
exp(-1j*2*pi*1e9*tau)
```

Array Response

To obtain the array response, which is a weighted-combination of the steering vector elements for each incident angle, use `phased.ArrayResponse`.

Construct a two-element ULA with elements spaced at 0.5 m. Obtain the array's magnitude response (absolute value of the complex-valued array response) for azimuth angles `-180:180` and plot the normalized magnitude response in decibels.

```
hula = phased.ULA('NumElements',2,'ElementSpacing',0.5);  
azangles = -180:180;  
har = phased.ArrayResponse('SensorArray',hula);  
resp = abs(step(har,1e9,azangles));  
plot(azangles,mag2db((resp/max(resp))));  
grid on;  
title('Azimuth Cut at Zero Degrees Elevation');  
xlabel('Azimuth Angle (degrees)');
```

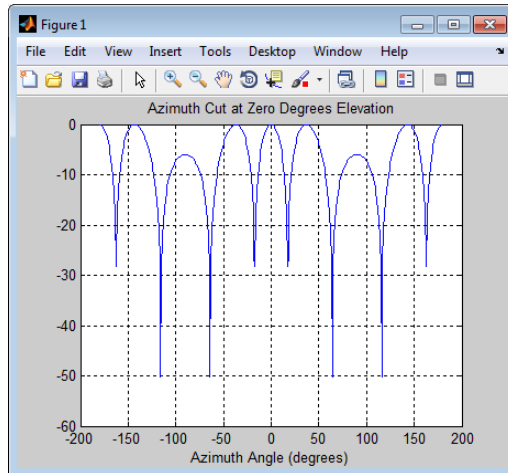

Visualize the array response using the `plotResponse` method. This example uses options to create a 3-D plot of the response in u/v space; other plotting options are available.

```
figure;
plotResponse(hula,1e9,physconst('LightSpeed'),...
    'Format','UV','RespCut','3D')
```

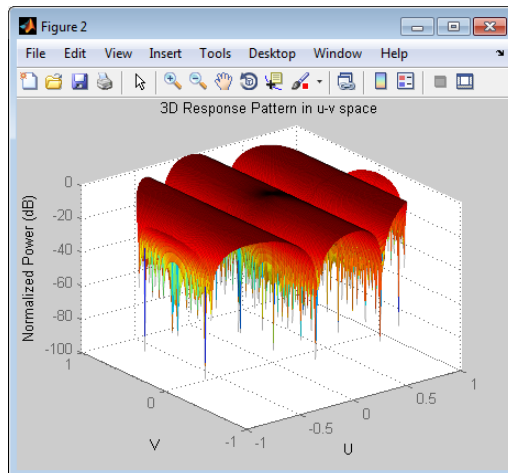

Reception of Plane Wave Across Array

You can simulate the effects of phase shifts across your array using the `collectPlaneWave` method.

The `collectPlaneWave` method modulates input signals by the element of the steering vector corresponding to an array element. Stated differently, `collectPlaneWave` accounts for phase shifts across elements in the array based on the angle of arrival. However, `collectPlaneWave` does not account for the response of individual elements in the array.

Simulate the reception of a 100-Hz sine wave modulated by a carrier frequency of 1 GHz at a 4-element ULA. Assume the angle of arrival of the signal is `[-90; 0]`.

```
hula = phased.ULA(4);  
t = unigrid(0,0.001,0.01,'[]');  
% signals must be column vectors  
x = cos(2*pi*100*t)';  
y = collectPlaneWave(hula,x,[-90;0],1e9,physconst('LightSpeed'));
```

The preceding code is equivalent to the following.

```
hsv = phased.SteeringVector('SensorArray',hula);  
sv = step(hsv,1e9,[-90;0]);  
y1 = x*sv.'
```

Related Examples

- “Microphone Array” on page 2-9

Microphone Array

This example shows how to construct and visualize a four-element ULA with custom cardioid microphone elements.

Create a microphone element with a cardioid response pattern. Use the default `FrequencyVector` of `[20 20e3]`. Specify the polar pattern frequencies as `[500 1000]`.

```
freq = [500 1000];
hmic = phased.CustomMicrophoneElement(...
    'PolarPatternFrequencies',freq);
hmic.PolarPattern= mag2db([...
    0.5+0.5*cosd(hmic.PolarPatternAngles);...
    0.6+0.4*cosd(hmic.PolarPatternAngles)]);
```

Plot the polar pattern of the microphone at 0.5 kHz and 1 kHz.

```
plotResponse(hmic,freq,'Format','Polar');
```

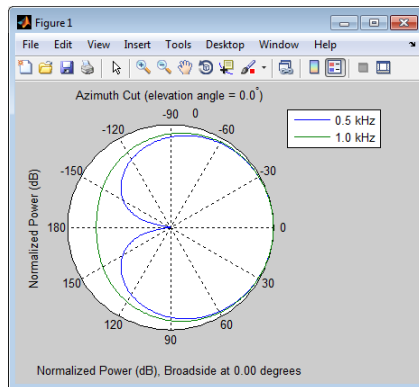

Assign the custom microphone element as the `Element` property of a `phased.ULA` object.

```
ha = phased.ULA('NumElements',4,'ElementSpacing',0.5,...
    'Element',hmic);
```

Plot the response of the array at 0.5 kHz and 1 kHz.

```
figure;  
plotResponse(ha, freq, 340, 'Format', 'Polar')
```

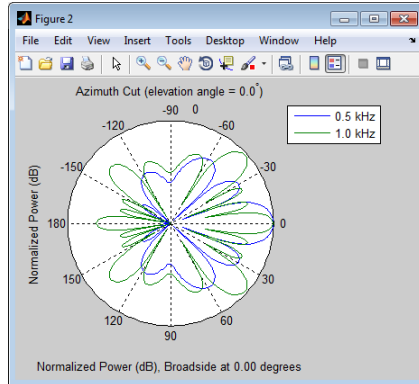

Uniform Rectangular Array

In this section...

“Support for Uniform Rectangular Arrays” on page 2-11

“Uniform Rectangular Array with Isotropic Antenna Elements” on page 2-11

Support for Uniform Rectangular Arrays

You can implement a uniform rectangular array (URA) with `phased.URA`. Array elements are distributed in the yz -plane with the array look direction along the positive x -axis. When you use `phased.URA`, you must specify these aspects of the array:

- Sensor elements of the array
- Number of rows and the spacing between them
- Number of columns and the spacing between them
- Geometry of the planar lattice, which can be rectangular or triangular

Uniform Rectangular Array with Isotropic Antenna Elements

This example shows how to create a URA, get information about its element positions, response, and delays, and simulate its reception of two sine waves.

Create and view a six-element URA with two elements along the y -axis and three elements along the z -axis. Use a rectangular lattice, with the default spacing of 0.5 meters along both the row and column dimensions of the array. Each element is an isotropic antenna element, which is the default. Return the positions of the array elements.

```
hura = phased.URA([3 2]);  
viewArray(hura);  
pos = getElementPosition(hura);
```

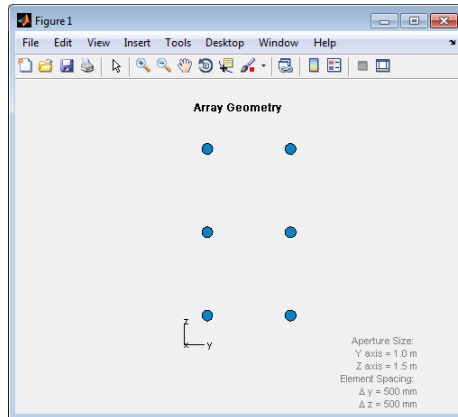

The x -coordinate is zero for all elements in the array.

You can plot the array response using the `plotResponse` method.

```
% Plot the response in 3D
figure;
plotResponse(hura,1e9,physconst('LightSpeed'),'RespCut','3D')
```

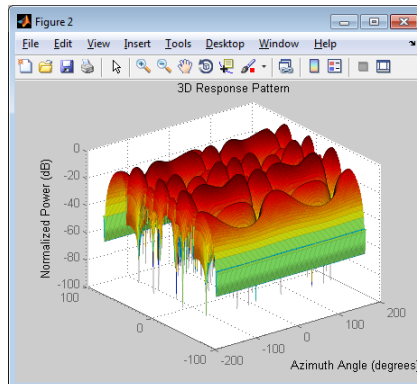

Calculate the element delays for signals arriving from ± 45 degrees azimuth and 0 degrees elevation.

```
hed = phased.ElementDelay('SensorArray',hura);
ang = [45 -45];
```

```
tau = step(hed,ang);
```

The first column of `tau` contains the element delays for the signal incident on the array from +45 degrees azimuth and the second column contains the delays for the signal arriving from -45 degrees. The delays are equal in magnitude but opposite in sign as expected.

The following code simulates the reception of two sine waves arriving from far field sources. One of the signals is a 100-Hz sine wave arriving from 20 degrees azimuth and 10 degrees elevation. The other signal is a 300-Hz sine wave arriving from -30 degrees azimuth and 5 degrees elevation. Both signals have a one GHz carrier frequency.

```
t = linspace(0,1,1000);  
x = cos(2*pi*100*t)';  
y = cos(2*pi*300*t)';  
angx = [20; 10];  
angy = [-30;5];  
recsig = collectPlaneWave(hura,[x y],[angx angy],1e9);
```

Each column of `recsig` represents the received signal at the corresponding element of the URA, `hura`.

Conformal Array

In this section...
“Support for Arrays with Custom Geometry” on page 2-14
“Uniform Circular Array” on page 2-15
“Custom Antenna Array” on page 2-16

Support for Arrays with Custom Geometry

The `phased.ConformalArray` object lets you model a phased array with arbitrary geometry. For example, you can use `phased.ConformalArray` to design:

- A planar array with a nonrectangular geometry, such as a circular array
- An array with nonuniform geometry, such as a linear array with variable spacing
- A nonplanar array

When you use `phased.ConformalArray`, you must specify these aspects of the array:

- Sensor element of the array
- Element positions
- Direction normal to each array element

To create a conformal array with default properties, use this command:

```
hcon = phased.ConformalArray
```

This default conformal array consists of a single `phased.IsotropicAntennaElement` sensor element located at the origin of the local coordinate system. The direction normal to the sensor element is 0 degrees azimuth and 0 degrees elevation.

Uniform Circular Array

This example shows how to construct a uniform circular array consisting of 60 elements. Assume an operating frequency of 400 MHz. Specify the arc length between the elements to be 0.5λ where λ is the wavelength of the operating frequency. The element normal directions are equal to $[\text{ang}; 0]$ where ang is the azimuth angle of the array element.

```
% Angle spacing in degrees
theta = 360/60;
% Angle spacing in radians
thetarad = degtorad(theta);
% Arc length 0.5*wavelength of operating frequency
arclength = 0.5*(physconst('LightSpeed')/4e8);
radius = arclength/thetarad;
% Number of elements
N = 60;
% Element angles in degrees
ang = (0:N-1)*theta;
% Azimuth angles must be between [-180,180]
ang(32:end)=ang(32:end)-360;
hcirc = phased.ConformalArray;
hcirc.ElementPosition = [radius*cosd(ang);...
    radius*sind(ang);...
    zeros(1,N)];
hcirc.ElementNormal = [ang; zeros(1,N)];

viewArray(hcirc);
figure;
plotResponse(hcirc,1e9,physconst('LightSpeed'),'Format','Polar')
```

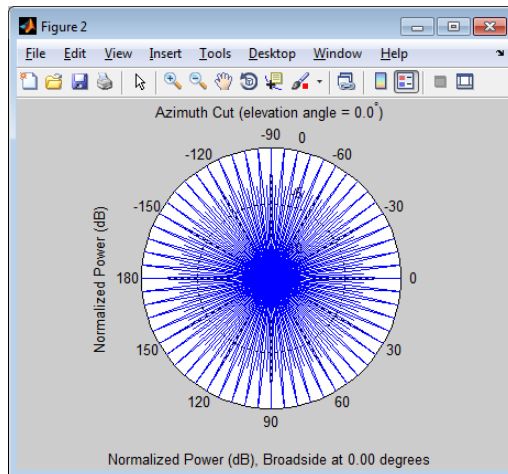
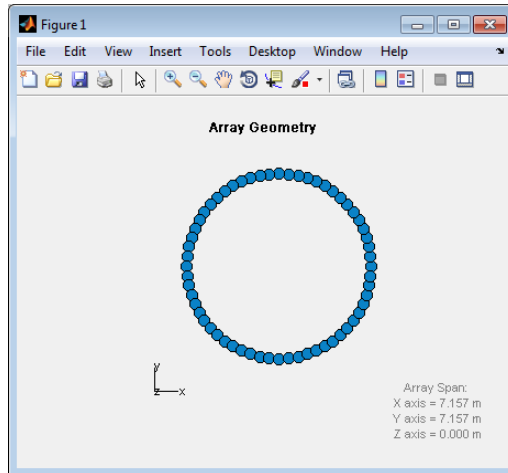

Custom Antenna Array

This example shows how to construct and visualize a custom-geometry array containing antenna elements with a custom radiation pattern. The radiation pattern of each element is constant over each azimuth angle and has a cosine pattern for the elevation angles.

Define the antenna element and plot its radiation pattern.

```

Az = -180:180;
El = -90:90;
Elresp = cosd(El);
hele = phased.CustomAntennaElement('AzimuthAngles',Az,...
    'ElevationAngles',El,...
    'RadiationPattern', repmat(Elresp',1,numel(Az)));
plotResponse(hele,3e8,'Format','Polar','RespCut','El')

```

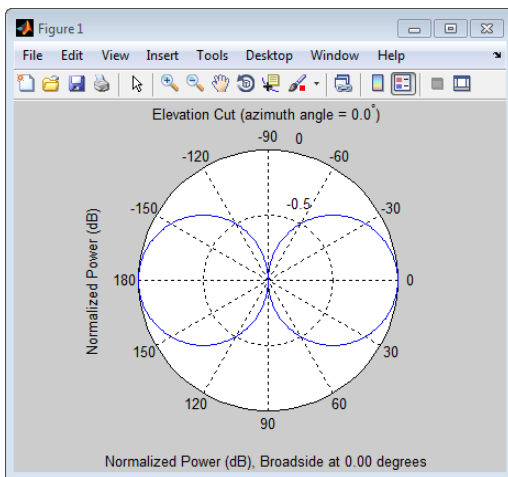

Define the locations and normal directions of the elements. In this case, the elements are located at $[1;0;0]$, $[0;1;0]$, and $[0;-1;0]$. The element normal azimuth angles are 0, 120, and -120 degrees respectively. All normal elevation angles are 0 degrees.

```

xpos = [1 0 0];
ypos = [0 1 -1];
zpos = [0 0 0];
normal_az = [0 120 -120];
normal_el = [0 0 0];

```

Define a conformal array with those elements.

```

ha = phased.ConformalArray('Element',hele,...
    'ElementPosition',[xpos; ypos; zpos],...
    'ElementNormal',[normal_az; normal_el]);

```

Plot the positions and normal directions of the elements.

```
figure;  
viewArray(ha, 'ShowNormals', true)  
view(0,90)
```

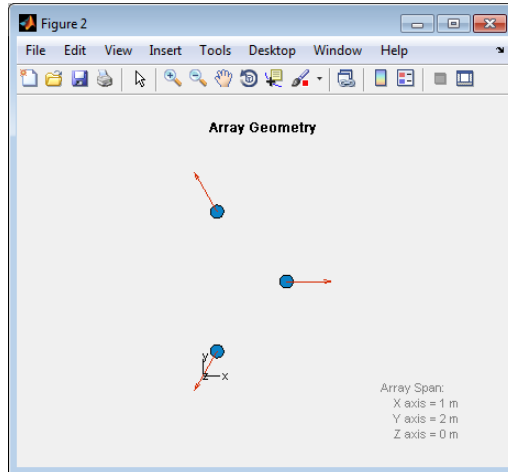

Plot the response of the conformal array.

```
figure;  
plotResponse(ha, 3e8, 3e8, 'Format', 'Polar', 'RespCut', '3D')
```

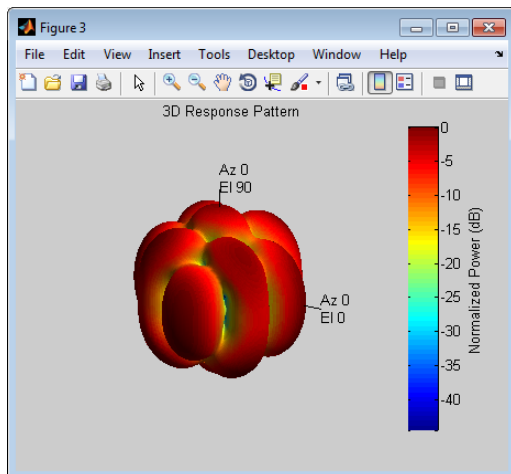
Subarrays Within Arrays

In this section...
“Definition of Subarrays” on page 2-20
“Benefits of Using Subarrays” on page 2-20
“Support for Subarrays Within Arrays” on page 2-20
“Rectangular Array Partitioned into Linear Subarrays” on page 2-22
“Linear Subarray Replicated to Form Rectangular Array” on page 2-25
“Linear Subarray Replicated in a Custom Grid” on page 2-26

Definition of Subarrays

In Phased Array System Toolbox™ software, a *subarray* is an accessible subset of array elements. When you use an array that contains subarrays, you can access measurements from the subarrays but not from the individual elements. Similarly, you can perform processing at the subarray level but not at the level of the individual elements. As a result, the system has fewer degrees of freedom than if you controlled the system at the level of the individual elements.

Benefits of Using Subarrays

Radar applications often use subarrays because operations, such as phase shifting and analog-to-digital conversion, are too expensive to implement for each element. It is less expensive to group the elements of an array through hardware, thus creating subarrays within the array. Grouping elements through hardware limits access to measurements and processing to the subarray level.

Support for Subarrays Within Arrays

To work with subarrays, you must define the array and the subarrays within it. You can either define the array first or begin with the subarray. Choose one of these approaches:

- Define one subarray, and then build a larger array by arranging copies of the subarray. The subarray can be a ULA, URA, or conformal array. The copies are identical, except for their location and orientation. You can arrange the copies spatially in a grid or a custom layout.

When you use this approach, you build the large array by creating a `phased.ReplicatedSubarray` System object™. This object stores information about the subarray and how the copies of it are arranged to form the larger array.

- Define an array, and then partition it into subarrays. The array can be a ULA, URA, or conformal array. The subarrays do not need to be identical. A given array element can be in more than one subarray, leading to *overlapped subarrays*.

When you use this approach, you partition your array by creating a `phased.PartitionedArray` System object. This object stores information about the array and its subarray structure.

After you create a `phased.ReplicatedSubarray` or `phased.PartitionedArray` object, you can use it to perform beamforming, steering, or other operations. To do so, specify your object as the value of the `SensorArray` or `Sensor` property in objects that have such a property and that support subarrays. Objects that support subarrays in their `SensorArray` or `Sensor` property include:

- `phased.AngleDopplerResponse`
- `phased.ArrayGain`
- `phased.ArrayResponse`
- `phased.Collector`
- `phased.ConstantGammaClutter`
- `phased.MVDRBeamformer`
- `phased.PhaseShiftBeamformer`
- `phased.Radiator`
- `phased.STAPSMIBeamformer`
- `phased.SteeringVector`

- `phased.SubbandPhaseShiftBeamformer`
- `phased.WidebandCollector`

Rectangular Array Partitioned into Linear Subarrays

This example shows how to set up a rectangular array containing linear subarrays. The example also finds the phase centers of the subarrays.

Create a 2-by-3 rectangular array.

```
ha = phased.URA('Size',[2 3]);
```

Plot the positions of the array elements in the yz plane. (All the x coordinates are zero.) Include labels that indicate the numbering of the elements. The numbering is important for selecting which elements are in each subarray.

```
viewArray(ha,'ShowIndex','All')
```

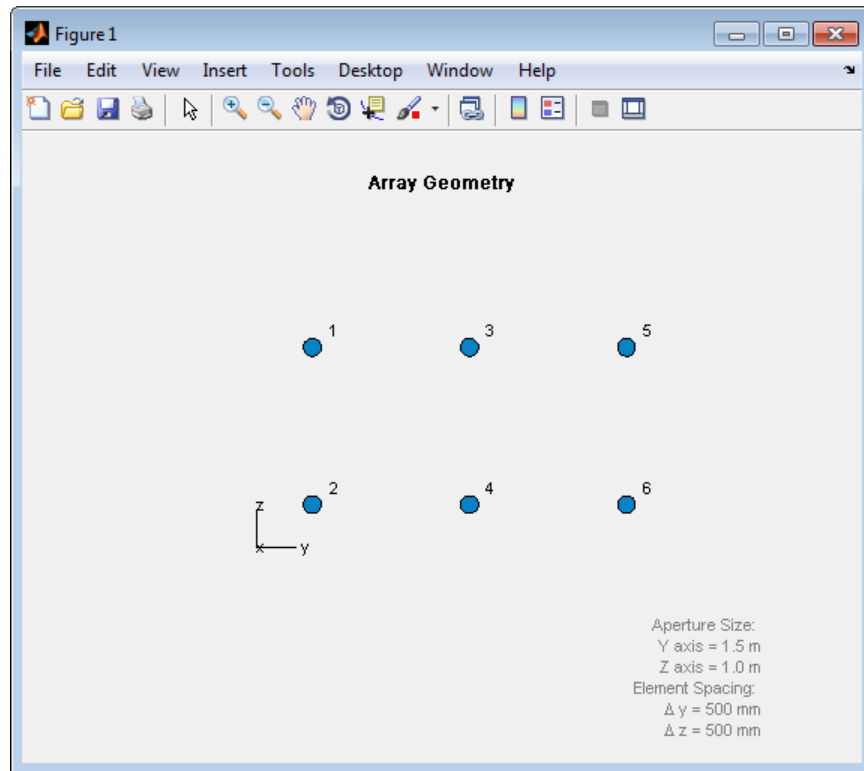

Create and view an array consisting of three 2-element linear subarrays each parallel to the z -axis. Use the numbers in the plot to help form the matrix for the `SubarraySelection` property. Also, find the phase centers of the three subarrays.

```
subarray1 = [1 1 0 0 0 0; 0 0 1 1 0 0; 0 0 0 0 1 1];
hpa1 = phased.PartitionedArray('Array',ha,...
    'SubarraySelection',subarray1);
subarraypos1 = getSubarrayPosition(hpa1);
figure;
viewArray(hpa1)
```

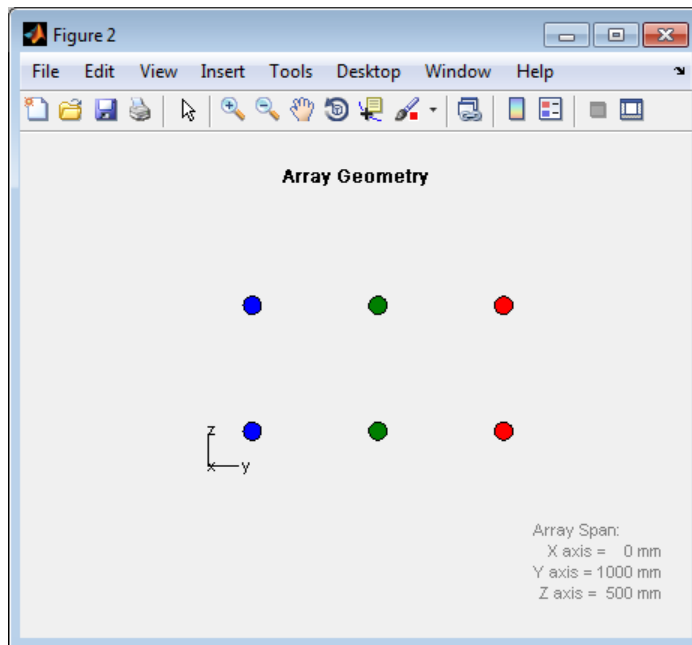

Create and view another array consisting of two 3-element linear subarrays parallel to the y -axis. Find the phase centers of the two subarrays.

```
subarray2 = [0 1 0 1 0 1; 1 0 1 0 1 0];  
hpa2 = phased.PartitionedArray('Array',ha,...  
    'SubarraySelection',subarray2);  
subarraypos2 = getSubarrayPosition(hpa2);  
figure;  
viewArray(hpa2)
```

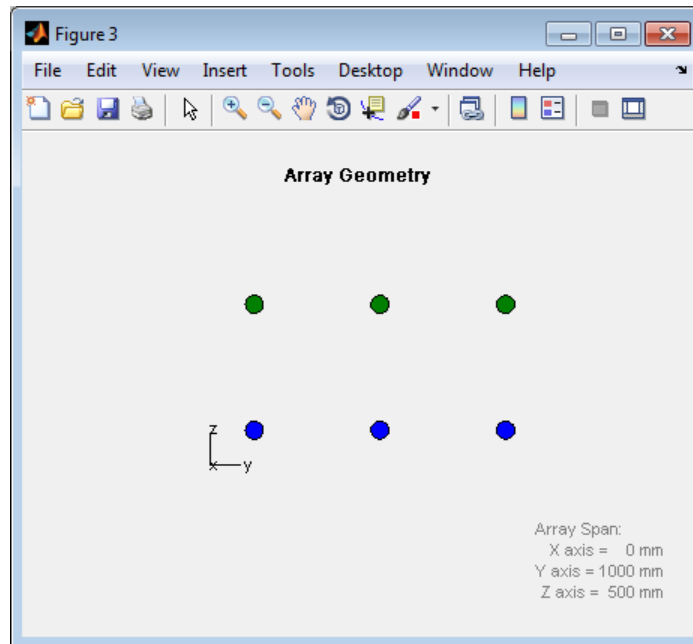

Linear Subarray Replicated to Form Rectangular Array

This example shows how to arrange copies of a linear subarray to form a rectangular array.

Create a 4-element linear array parallel to the y -axis.

```
ha = phased.ULA('NumElements',4);
```

Create a rectangular array by arranging two copies of the linear array.

```
hrs = phased.ReplicatedSubarray('Subarray',ha,...
    'GridSize',[2 1]);
```

Plot the positions of the array elements and the phase centers of the subarrays. The plot is in the yz plane because all the x coordinates are zero.

```
viewArray(hrs);
```

```
hold on;  
  
subarraypos = getSubarrayPosition(hrs);  
sx = subarraypos(1,:);  
sy = subarraypos(2,:);  
sz = subarraypos(3,:);  
scatter3(sx,sy,sz,'r*');  
hold off
```

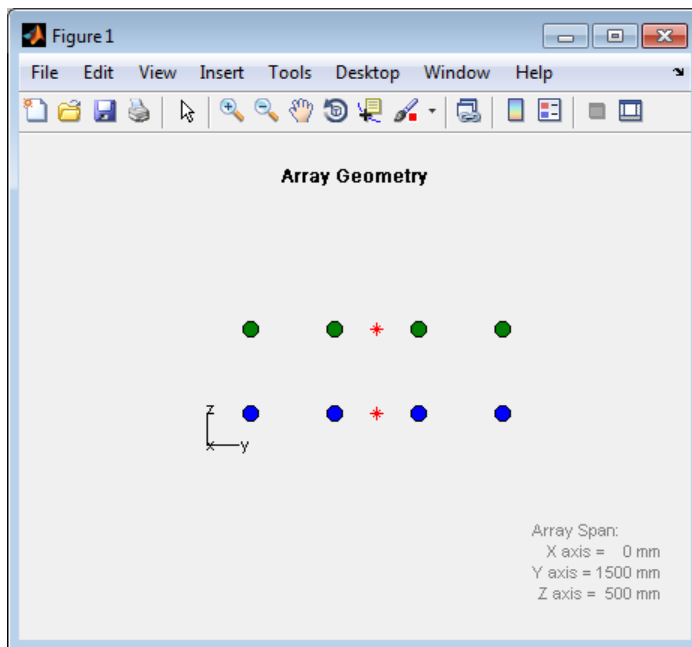

Linear Subarray Replicated in a Custom Grid

This example shows how to arrange copies of a linear subarray in a triangular layout.

Create a 4-element linear array.

```
hele = phased.CosineAntennaElement('CosinePower',1);  
ha = phased.ULA('NumElements',4,'Element',hele);
```

Create a larger array by arranging three copies of the linear array. Define the phase centers and normal directions of the three copies explicitly.

```
vertex_ang = [60 180 -60];
vertex = 2*[cosd(vertex_ang); sind(vertex_ang); zeros(1,3)];
subarray_pos = 1/2*[...
    (vertex(:,1)+vertex(:,2)) ...
    (vertex(:,2)+vertex(:,3)) ...
    (vertex(:,3)+vertex(:,1))];
hrs = phased.ReplicatedSubarray('Subarray',ha,...
    'Layout','Custom',...
    'SubarrayPosition',subarray_pos,...
    'SubarrayNormal',[120 0;-120 0;0 0].');
```

Plot the positions of the array elements and the phase centers of the subarrays. The plot is in the xy plane because all the z coordinates are zero.

```
viewArray(hrs, 'ShowSubarray', []);
hold on;
scatter3(subarray_pos(1,:),subarray_pos(2,:),...
    subarray_pos(3,:), 'r*');
hold off
```

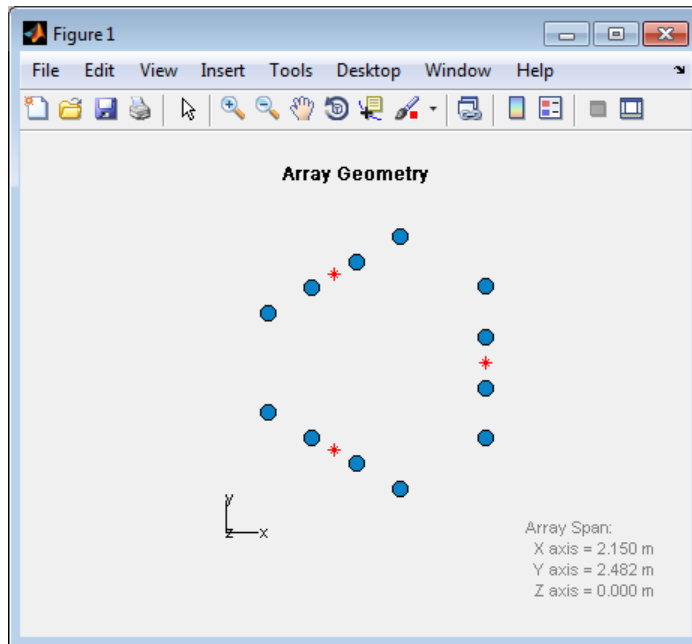

Related Examples

- Subarrays in Phased Array Antennas

Signal Radiation and Collection

- “Signal Radiation” on page 3-2
- “Signal Collection” on page 3-4

Signal Radiation

In this section...

“Support for Modeling Signal Radiation” on page 3-2

“Radiate Signal with Uniform Linear Array” on page 3-2

Support for Modeling Signal Radiation

You can use the `phased.Radiator` and `phased.Collector` objects to model narrowband signal radiation and collection with an array. The array can be a single microphone or antenna element, or an array of sensor elements.

To radiate a signal from a sensor array, use `phased.Radiator`. When you use this object, you must specify these aspects of the radiator:

- Whether the output of all sensor elements is combined
- Operating frequency of the array
- Propagation speed of the wave
- Sensor (single element) or sensor array
- Whether to apply weights to signals radiated by different elements in the array. If you want to apply weights, you specify them when you call the `step` method.

Radiate Signal with Uniform Linear Array

Construct a radiator using a two-element ULA with elements spaced 0.5 meters apart (the default ULA). The operating frequency is 300 MHz, the propagation speed is the speed of light, and the element outputs are combined to simulate the far field radiation pattern.

```
hula = phased.ULA('NumElements',2,'ElementSpacing',0.5);
hrad = phased.Radiator('Sensor',hula,...
    'OperatingFrequency',3e8,...
    'PropagationSpeed',physconst('LightSpeed'),...
    'CombineRadiatedSignals',true)
% create signal to radiate
x = [1 -1 1 -1]';
```

```
% model far field radiation at an angle of [45;0]
y = step(hrad,x,[45;0]);
```

The far field signal results from multiplying the signal by the *array pattern*. The array pattern is the product of the *array element pattern* and the *array factor*. For a uniform linear array, the array factor is the superposition of elements in the steering vector (see `phased.SteeringVector`).

The following code produces an identical far field signal by explicitly using the array factor.

```
hula = phased.ULA('NumElements',2,'ElementSpacing',0.5);
hsv = phased.SteeringVector('SensorArray',hula,...
    'IncludeElementResponse',true);
sv = step(hsv,3e8,[45;0]);
y1 = x*sum(sv);
% compare y1 to y
```

Signal Collection

In this section...

“Support for Modeling Signal Collection” on page 3-4

“Narrowband Collector for Uniform Linear Array” on page 3-5

“Narrowband Collector for a Single Antenna Element” on page 3-6

“Wideband Signal Collection” on page 3-7

Support for Modeling Signal Collection

To model the collection of a signal with a sensor element or sensor array, you can use the `phased.Collector` or `phased.WideBandCollector`. Both collector objects assume that incident signals have propagated to the location of the array elements, but have not been received by the array. In other words, the collector objects do not model the actual reception by the array. See “Receiver Preamplifier” on page 4-32 for signal effects related to the gain and internal noise of the array’s receiver.

In many array processing applications, the ratio of the signal’s bandwidth to the carrier frequency is small. Expressed as a percentage, this ratio does not exceed a few percent. Examples include radar applications where a pulse waveform is modulated by a carrier frequency in the microwave range. These are *narrowband* signals. For narrowband signals, you can express the steering vector as a function of a single frequency, the carrier frequency. For narrowband signals, the `phased.Collector` object is appropriate.

In other applications, the narrowband assumption is not justified. In many acoustic and sonar applications, the wave impinging on the array is a pressure wave that is unmodulated. It is not possible to express the steering vector as a function of a single frequency. In these cases, the subband approach implemented in `phased.WideBandCollector` is appropriate. The wideband collector decomposes the input into subbands and computes the steering vector for each subband.

When you use the narrowband collector, `phased.Collector`, you must specify these aspects of the collector:

- Operating frequency of the array
- Propagation speed of the wave
- Sensor (single element) or sensor array
- Type of incoming wave. Choices are 'Plane' and 'Unspecified'. If you select 'Plane', the input signals are multiple plane waves impinging on the entire array. Each plane wave is received by all collecting elements. If you select 'Unspecified', the input signal are individual waves impinging on individual sensors.
- Whether to apply weights to signals collected by different elements in the array. If you want to apply weights, you specify them when you call the `step` method.

When you use the wideband collector, `phased.WidebandCollector`, you must specify these aspects of the collector:

- Carrier frequency
- Whether the signal is demodulated to the baseband
- Operating frequency of the array
- Propagation speed of the wave
- Sampling rate
- Sensor (single element) or sensor array
- Type of incoming wave. Choices are 'Plane' and 'Unspecified'. If you select 'Plane', the input signals are multiple plane waves impinging on the entire array. Each plane wave is received by all collecting elements. If you select 'Unspecified', the input signal are individual waves impinging on individual sensors.
- Whether to apply weights to signals collected by different elements in the array. If you want to apply weights, you specify them when you call the `step` method.

Narrowband Collector for Uniform Linear Array

This example shows how to construct a narrowband collector that models a plane wave impinging on a two-element uniform linear array. The array

has an element spacing of 0.5 m (default ULA). The operating frequency of the array is 300 MHz.

```
hula = phased.ULA('NumElements',2,'ElementSpacing',0.5);
hcol = phased.Collector('Sensor',hula,...
    'PropagationSpeed',physconst('LightSpeed'),...
    'OperatingFrequency',3e8,'Wavefront','Plane')
% create signal to create
x =[1 -1 1 -1]';
% simulate reception from an angle of [45;0]
y = step(hcol,x,[45;0]);
```

In the preceding case, the collector object multiplies the input signal, x , by the corresponding element of the steering vector for the two-element ULA. The following code produces the response in an equivalent manner.

```
% default ULA
hula = phased.ULA('NumElements',2,'ElementSpacing',0.5);
% Construct steering vector
hsv = phased.SteeringVector('SensorArray',hula);
sv = step(hsv,3e8,[45;0]);
x =[1 -1 1 -1]';
y1 = x*sv.';
% compare y1 to y
```

Narrowband Collector for a Single Antenna Element

The `Sensor` property of `phased.Collector` can consist of a single antenna element. In this example, create a custom antenna element using `phased.CustomAntennaElement`. The antenna element has a cosine response over elevation angles from $[-90,90]$ degrees. Plot the polar pattern response of the antenna at 1 GHz using an elevation cut at zero degrees azimuth. Determine the antenna voltage response at 0 degrees azimuth and 45 degrees elevation.

```
ha = phased.CustomAntennaElement;
ha.AzimuthAngles = -180:180;
ha.ElevationAngles = -90:90;
ha.RadiationPattern = mag2db(...
    repmat(cosd(ha.ElevationAngles)',1,numel(ha.AzimuthAngles)));
plotResponse(ha,1e9,'Format','polar','RespCut','E1');
```



```
resp = step(ha,1e9,[0; 45])
```

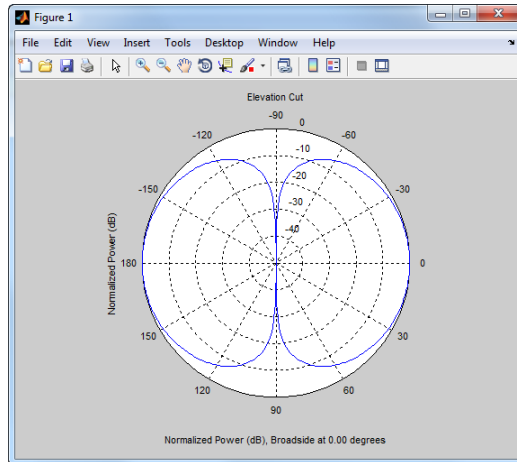

The antenna voltage response at zero degrees azimuth and 45 degrees elevation is $\text{cosd}(45)$ as expected.

Assume a narrowband sinusoidal input incident on the antenna element from 0 degrees azimuth and 45 degrees elevation. Determine the signal collected at the element.

```
hc = phased.Collector('Sensor',ha,'OperatingFrequency',1e9)
x =[1 -1 1 -1]';
y = step(hc,x,[0; 45]);
% equivalent to y1 = x*cosd(45);
```

Wideband Signal Collection

This example shows how to simulate the reception of a wideband acoustic signal by a single omnidirectional microphone element.

```
x = randn(10,1);
hmic = phased.OmnidirectionalMicrophoneElement(...
    'FrequencyRange',[20 20e3],'BackBaffled',true)
hwb = phased.WidebandCollector('Sensor',hmic,...
    'PropagationSpeed',340,'SampleRate',50e3,...
    'ModulatedInput',false)
y = step(hwb,x,[30;10]);
```

Waveforms, Transmitter, and Receiver

- “Rectangular Pulse Waveforms” on page 4-2
- “Linear Frequency Modulated Pulse Waveforms” on page 4-6
- “Stepped FM Pulse Waveforms” on page 4-13
- “FMCW Waveforms” on page 4-16
- “Phase-Coded Waveforms” on page 4-19
- “Waveforms with Staggered PRFs” on page 4-24
- “Transmitter” on page 4-26
- “Receiver Preamp” on page 4-32
- “Radar Equation” on page 4-37

Rectangular Pulse Waveforms

In this section...

“Definition of Rectangular Pulse Waveform” on page 4-2

“How to Create Rectangular Pulse Waveforms” on page 4-2

“Rectangular Waveform Plot” on page 4-3

“Pulses of Rectangular Waveform” on page 4-4

Definition of Rectangular Pulse Waveform

Define the following function of time:

$$a(t) = \begin{cases} 1 & 0 \leq t \leq \tau \\ 0 & \text{otherwise} \end{cases}$$

Assume that a radar transmits a signal of the form:

$$x(t) = a(t) \sin(\omega_c t)$$

where ω_c denotes the carrier frequency. Note that $a(t)$ represents an on-off rectangular amplitude modulation of the carrier frequency. After demodulation, the complex envelope of $x(t)$ is the real-valued rectangular pulse $a(t)$ of duration τ seconds.

How to Create Rectangular Pulse Waveforms

To create a rectangular pulse waveform, use `phased.RectangularWaveform`. You can customize certain characteristics of the waveform, including:

- Sampling rate
- Pulse duration
- Pulse repetition frequency
- Number of samples or pulses in each vector that represents the waveform

Rectangular Waveform Plot

This example shows how to create a rectangular pulse waveform variable using `phased.RectangularWaveform`. The example also plots the pulse and finds the bandwidth of the pulse.

Construct a rectangular pulse waveform with a duration of 50 μs , a sample rate of 1 MHz, and a pulse repetition frequency (PRF) of 10 kHz.

```
hrect = phased.RectangularWaveform('SampleRate',1e6,...
    'PulseWidth',5e-5,'PRF',1e4);
```

Plot a single rectangular pulse by calling `plot` directly on the rectangular waveform variable.

```
figure;
plot(hrect)
```

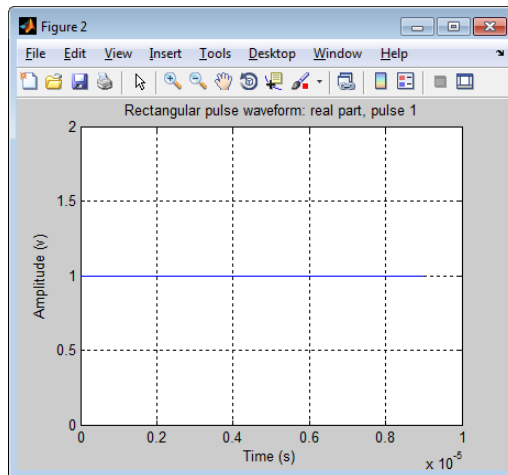

`plot` is a method of `phased.RectangularWaveform`. This plot method produces an annotated graph of your pulse waveform.

Find the bandwidth of the rectangular pulse.

```
bw = bandwidth(hrect);
```

The bandwidth of a rectangular pulse in hertz is approximately the reciprocal of that pulse's duration. That is, `bw` is approximately `1/hrect.PulseWidth`.

Pulses of Rectangular Waveform

This example shows how to create rectangular pulse waveform signals having different durations. The example plots two pulses of each waveform.

Create a rectangular pulse with a duration of 100 μ s and a PRF of 1 kHz. Set the number of pulses in the output equal to two.

```
hrect = phased.RectangularWaveform('PulseWidth',100e-6,...  
    'PRF',1e3,'OutputFormat','Pulses','NumPulses',2);
```

Make a copy of your rectangular pulse and change the pulse width in your original waveform to 10 μ s.

```
hrect1 = clone(hrect);  
hrect.PulseWidth = 10e-6;
```

`hrect1` and `hrect` now specify different rectangular pulses because you changed the pulse width of `hrect`.

Use the `step` method to return two pulses of your rectangular pulse waveforms.

```
y = step(hrect);  
y1 = step(hrect1);
```

Plot the real part of the waveforms.

```
totaldur = 2*1/hrect.PRF;  
totnumsamp = totaldur*hrect.SampleRate;  
t = unigrid(0,1/hrect.SampleRate,totaldur,['']);  
subplot(2,1,1)  
plot(t.*1000,real(y)); axis([0 totaldur*1e3 0 1.5]);  
title('Two 10-\musec duration pulses (PRF = 1 kHz)');  
set(gca,'XTick',0:0.2:totaldur*1e3)  
subplot(2,1,2);  
plot(t.*1000,real(y1)); axis([0 totaldur*1e3 0 1.5]);  
xlabel('Milliseconds');
```

```
title('Two 100-\musec duration pulses (PRF = 1 kHz)');  
set(gca,'XTick',0:0.2:totaldur*1e3)
```

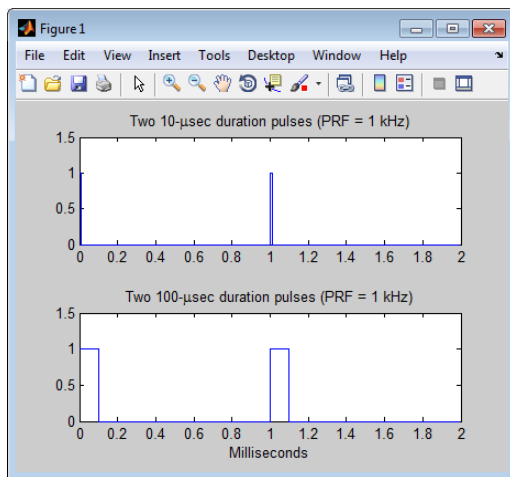

Linear Frequency Modulated Pulse Waveforms

In this section...

“Benefits of Using Linear FM Pulse Waveform” on page 4-6

“Definition of Linear FM Pulse Waveform” on page 4-6

“How to Create Linear FM Pulse Waveforms” on page 4-7

“Configuration of Linear FM Pulse Waveform” on page 4-8

“Linear FM Pulse Waveform Plots” on page 4-8

“Ambiguity Function of Linear FM Waveform” on page 4-10

“Comparing Autocorrelation for Rectangular and Linear FM Waveforms” on page 4-11

Benefits of Using Linear FM Pulse Waveform

Increasing the duration of a transmitted pulse increases its energy and improves target detection capability. Conversely, reducing the duration of a pulse improves the range resolution of the radar.

For a rectangular pulse, the duration of the transmitted pulse and the processed echo are effectively the same. Therefore, the range resolution of the radar and the target detection capability are coupled in an inverse relationship.

Pulse compression techniques enable you to decouple the duration of the pulse from its energy by effectively creating different durations for the transmitted pulse and processed echo. Using a linear frequency modulated pulse waveform is a popular choice for pulse compression.

Definition of Linear FM Pulse Waveform

The complex envelope of a linear FM pulse waveform with increasing instantaneous frequency is:

$$\tilde{x}(t) = a(t)e^{j\pi(\beta/\tau)t^2}$$

where β is the bandwidth and τ is the pulse duration.

If you denote the phase by $\Theta(t)$, the instantaneous frequency is:

$$\frac{1}{2\pi} \frac{d\Theta(t)}{dt} = \frac{\beta}{\tau} t$$

which is a linear function of t with slope equal to β/τ .

The complex envelope of a linear FM pulse waveform with decreasing instantaneous frequency is:

$$\tilde{x}(t) = a(t)e^{-j\pi\beta/\tau(t^2-2\tau t)}$$

Pulse compression waveforms have a time-bandwidth product, $\beta\tau$, greater than 1.

How to Create Linear FM Pulse Waveforms

To create a linear FM pulse waveform, use `phased.LinearFMWaveform`. You can customize certain characteristics of the waveform, including:

- Sample rate
- Duration of a single pulse
- Pulse repetition frequency
- Sweep bandwidth
- Sweep direction (up or down), corresponding to increasing and decreasing instantaneous frequency
- Envelope, which describes the amplitude modulation of the pulse waveform. The envelope can be rectangular or Gaussian.
 - The rectangular envelope is as follows, where τ is the pulse duration.

$$a(t) = \begin{cases} 1 & 0 \leq t \leq \tau \\ 0 & \text{otherwise} \end{cases}$$

- The Gaussian envelope is:

$$a(t) = e^{-t^2/\tau^2} \quad t \geq 0$$

- Number of samples or pulses in each vector that represents the waveform

Configuration of Linear FM Pulse Waveform

This example shows how to create a linear FM pulse waveform using `phased.LinearFMWaveform`. The example illustrates specific property settings.

Create a linear FM pulse with a sample rate of 1 MHz, a pulse duration of 50 μ s with an increasing instantaneous frequency, and a sweep bandwidth of 100 kHz. The amplitude modulation is rectangular.

```
hfm1 = phased.LinearFMWaveform('SampleRate',1e6,...  
    'PulseWidth',5e-5,'PRF',1e4,...  
    'SweepBandwidth',1e5,'SweepDirection','Up',...  
    'Envelope','Rectangular',...  
    'OutputFormat','Pulses','NumPulses',1);
```

Linear FM Pulse Waveform Plots

This example shows how to design a linear FM pulse waveform, plot the real part of the waveform, and plot one pulse repetition interval.

Design a linear FM pulse waveform with a duration of 100 μ s, a bandwidth of 200 kHz, and a PRF of 1 kHz. Use the default values for the other properties. Compute the time-bandwidth product and plot the real part of the pulse waveform.

```
hfm = phased.LinearFMWaveform('PulseWidth',100e-6,...  
    'SweepBandwidth',2e5,'PRF',1e3);  
disp(hfm.PulseWidth*hfm.SweepBandwidth)  
plot(hfm)
```

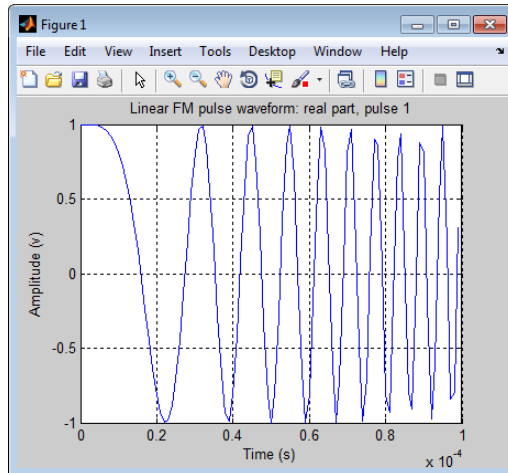

Use the `step` method to obtain your pulse waveform signal. Plot the real and imaginary parts of one pulse repetition interval.

```

y = step(hfm);
t = unigrid(0,1/hfm.SampleRate,1/hfm.PRF,'[]');
figure;
subplot(2,1,1)
plot(t,real(y))
axis tight;
title('Real Part');
subplot(2,1,2);
plot(t,imag(y)); xlabel('Seconds');
title('Imaginary Part');
axis tight;

```

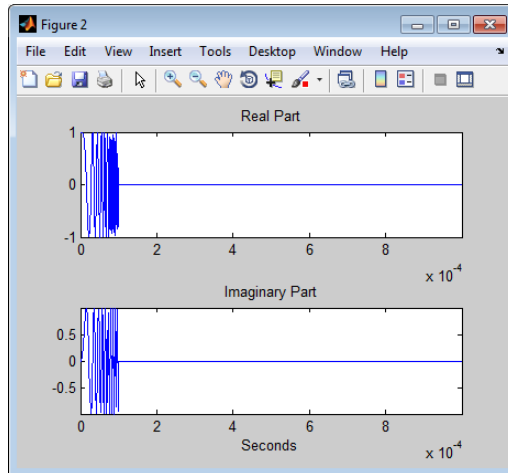

Ambiguity Function of Linear FM Waveform

This example shows how to plot the ambiguity function of the linear FM pulse waveform.

Define and set up the linear FM waveform.

```
h1fm = phased.LinearFMWaveform('PulseWidth',100e-6,...
    'SweepBandwidth',2e5,'PRF',1e3);
```

Generate samples of the waveform.

```
x = step(h1fm);
```

Create a 3-D surface plot of the ambiguity function for the waveform.

```
[afmag_1fm,delay_1fm,doppler_1fm] = ambgfun(x,...
    h1fm.SampleRate,h1fm.PRF);
surf(delay_1fm*1e6,doppler_1fm/1e3,afmag_1fm,...
    'LineStyle','none');
axis tight; grid on; view([140,35]); colorbar;
xlabel('Delay \tau (\mus)');
ylabel('Doppler f_d (kHz)');
title('Linear FM Pulse Waveform Ambiguity Function');
```

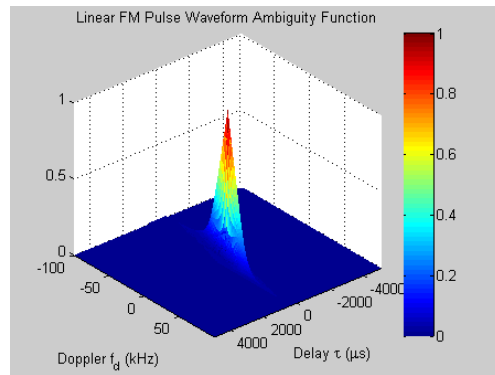

The surface has a narrow ridge that is slightly tilted. The tilt indicates better resolution in the zero delay cut. For a more detailed analysis of waveforms using the ambiguity function, see *Waveform Analysis Using the Ambiguity Function*.

Comparing Autocorrelation for Rectangular and Linear FM Waveforms

This example shows how to compute and plot the ambiguity function magnitudes for a rectangular and linear FM pulse waveform. The zero Doppler cut (magnitudes of the autocorrelation sequences) illustrates pulse compression in the linear FM pulse waveform.

Create a rectangular waveform and a linear FM pulse waveform having the same duration and PRF. Generate samples of each waveform.

```
hrect = phased.RectangularWaveform('PRF',2e4);
hfm = phased.LinearFMWaveform('PRF',2e4);
xrect = step(hrect);
xfm = step(hfm);
```

Compute the ambiguity function magnitudes for each waveform.

```
[ambrect,delay] = ambgfun(xrect,hrect.SampleRate,hrect.PRF,...
    'Cut','Doppler');
ambfm = ambgfun(xfm,hfm.SampleRate,hfm.PRF,...
    'Cut','Doppler');
```

Plot the ambiguity function magnitudes.

```
subplot(211);
stem(delay, ambrect)
title('Autocorrelation of Rectangular Pulse');
axis([-5e-5 5e-5 0 1]); set(gca, 'XTick', 1e-5 * (-5:5))
subplot(212);
stem(delay, ambfm)
xlabel('Delay (seconds)');
title('Autocorrelation of Linear FM Pulse');
axis([-5e-5 5e-5 0 1]); set(gca, 'XTick', 1e-5 * (-5:5))
```

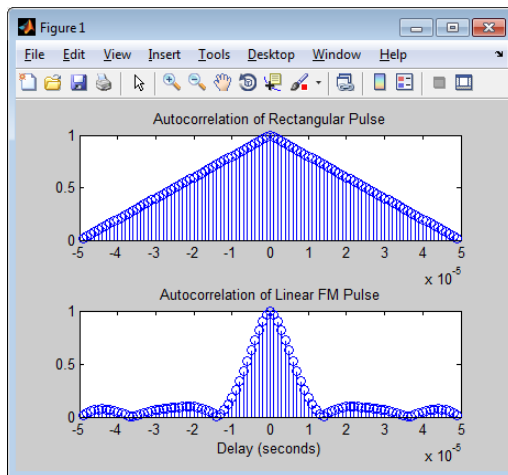

Related Examples

- Waveform Analysis Using the Ambiguity Function

Stepped FM Pulse Waveforms

A *stepped frequency pulse waveform* consists of a series of N narrowband pulses. The frequency is increased from step to step by a fixed amount, Δf , in Hz.

Similar to linear FM pulse waveforms, stepped frequency waveforms are a popular pulse compression technique. Using this approach enables you to increase the range resolution of the radar without sacrificing target detection capability.

To create a stepped FM pulse waveform, use `phased.SteppedFMWaveform`.

The stepped frequency pulse waveform has the following modifiable properties:

- `SampleRate` — Sampling rate in Hz
- `PulseWidth` — Pulse duration in seconds
- `PRF` — Pulse repetition frequency in Hz
- `FrequencyStep` — Frequency step in Hz
- `NumSteps` — Number of frequency steps
- `OutputFormat` — Output format in pulses or samples
- `NumSamples` — Number of samples in the output when the `OutputFormat` property is 'Samples'
- `NumPulses` — Number of pulses in the output when the `OutputFormat` property is 'Pulses'

Enter the following to construct a stepped FM pulse waveform with a pulse duration (width) of 50 μ s, a PRF of 10 kHz, and five steps of 20 kHz. The sampling rate is 1 MHz. By default the `OutputFormat` property is equal to 'Pulses' and the number of pulses in the output is equal to one. The example uses the `bandwidth` method to demonstrate that the bandwidth of the stepped FM pulse waveform is the product of the frequency step and the number of steps `Obj.FrequencyStep*Obj.Numsteps`.

```
hs = phased.SteppedFMWaveform('SampleRate',1e6,...
```

```
        'PulseWidth',5e-5,'PRF',1e4,...  
        'FrequencyStep',2e4,'NumSteps',5);  
bandwidth(hs)  
% equal to hs.NumSteps*hs.FrequencyStep
```

Because the `OutputFormat` property is set to `'Pulses'` and the `NumPulses` property is set to 1, calling the `step` method returns one pulse repetition interval (PRI). The pulse duration within that interval is equal to the `PulseWidth` property. The remainder of the PRI consists of zeros.

The initial pulse has a frequency of zero, and is a DC pulse. With the `NumPulses` property set to 1, each time you use `step`, the frequency of the narrowband pulse increments by the value of the `FrequencyStep` property. If you call `step` more times than the value of the `NumSteps` property, the process repeats, starting over with the DC pulse.

Use `step` to return successively higher frequency pulses. Plot the pulses one by one in the same figure window. Pause the loop to visualize the increment in frequency with each successive call to `step`. Make an additional call to `step` to demonstrate that the process starts over with the DC (rectangular) pulse.

```
t = unigrid(0,1/hh.SampleRate,1/hh.PRF, '[]');  
for i = 1:hh.NumSteps  
    plot(t,real(step(hh)));  
    pause(0.5);  
    axis tight;  
end  
% calling step again starts over with a DC pulse  
y = step(hh);
```

The next figure shows the plot in the final iteration of the loop.

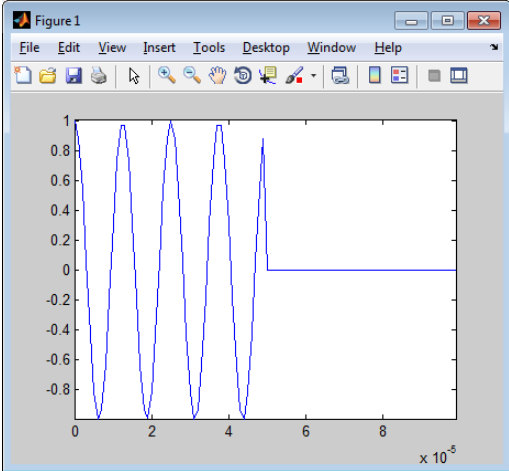

FMCW Waveforms

In this section...

“Benefits of Using FMCW Waveform” on page 4-16

“How to Create FMCW Waveforms” on page 4-16

“Double Triangular Sweep” on page 4-17

Benefits of Using FMCW Waveform

Radar systems that use frequency-modulated, continuous-wave (FMCW) waveforms are typically smaller and less expensive to manufacture than pulsed radar systems. FMCW waveforms can estimate the target range effectively, whereas the simplest continuous-wave waveforms cannot.

FMCW waveforms are common in automotive radar systems and ground-penetrating radar systems.

How to Create FMCW Waveforms

To create an FMCW waveform, use `phased.FMCWWaveform`. You can customize certain characteristics of the waveform, including:

- Sample rate.
- Period and bandwidth of the FM sweep. These quantities can cycle through multiple values during your simulation.

Tip To find targets up to a given maximum range, r , you can typically use a sweep period of approximately $5 \cdot \text{range2time}(r)$ or $6 \cdot \text{range2time}(r)$. To achieve a range resolution of delta_r , use a bandwidth of at least $\text{range2bw}(\text{delta}_r)$.

- Sweep shape. This shape can be sawtooth (up or down) or triangular.

Tip For moving targets, you can use a triangular sweep to resolve ambiguity between range and Doppler.

phased.FMCWaveform assumes that all frequency modulations are linear. For triangular sweeps, the slope of the down sweep is the opposite of the slope of the up sweep.

Double Triangular Sweep

This example shows how to sample an FMCW waveform with a double triangular sweep in which the two sweeps use different slopes. The example also plots a spectrogram.

Create an FMCW waveform object in which the `SweepTime` and `SweepBandwidth` properties are vectors of length two. For each period, the waveform alternates between the pairs of corresponding sweep time and bandwidth values.

```
st = [1e-3 1.1e-3];
bw = [1e5 9e4];
h = phased.FMCWaveform('SweepTime',st,...
    'SweepBandwidth',bw,'SweepDirection','Triangle',...
    'SweepInterval','Symmetric','SampleRate',2e5,...
    'NumSweeps',4);
```

Compute samples from four sweeps (two periods). In a triangular sweep, each period consists of an up sweep and down sweep.

```
x = step(h);
```

Plot a spectrogram.

```
[S,F,T] = spectrogram(x,32,16,32,h.SampleRate);
image(T,fftshift(F),fftshift(mag2db(abs(S))))
xlabel('Time'); ylabel('Frequency (Hz)');
```

4 Waveforms, Transmitter, and Receiver

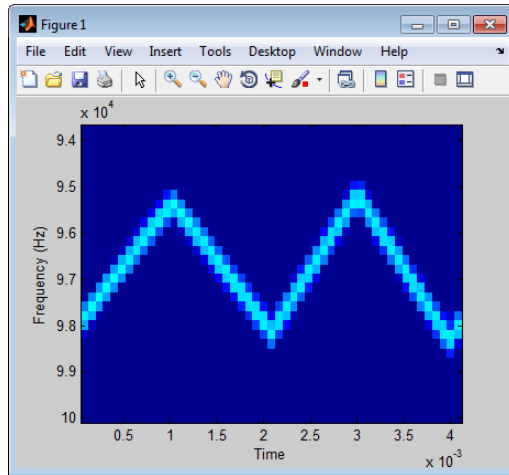

Phase-Coded Waveforms

In this section...

“When to Use Phase-Coded Waveforms” on page 4-19

“How to Create Phase-Coded Waveforms” on page 4-19

“Basic Radar Using Phase-Coded Waveform” on page 4-20

When to Use Phase-Coded Waveforms

Situations in which you might use a phase-coded waveform instead of another type of waveform include:

- When a rectangular pulse cannot provide both of these characteristics:
 - Short enough pulse for good range resolution
 - Enough energy in the signal to detect the reflected echo at the receiver
- When two or more radar systems are close to each other and you want to reduce interference among them.
- When digital processing suggests using a waveform with a discrete set of phases. For example, a Barker-coded waveform is a bi-phase waveform.

Conversely, you might use another waveform instead of a phase-coded waveform in the following situations:

- When you need to detect or track high-speed targets
Phase-coded waveforms tend to perform poorly when signals have Doppler shifts.
- When the hardware requirements for phase-coded waveforms are prohibitively expensive

How to Create Phase-Coded Waveforms

To create a phase-coded waveform, use `phased.PhaseCodedWaveform`. You can customize certain characteristics of the waveform, including:

- Type of phase code

- Number of chips
- Chip width
- Sample rate
- Pulse repetition frequency (PRF)
- Sequence index (Zadoff-Chu code only)

After you create a `phased.PhaseCodedWaveform` object, you can plot the waveform using the `plot` method of this class. You can also generate samples of the waveform using the `step` method.

For a full list of properties and methods, see the `phased.PhaseCodedWaveform` reference page.

Basic Radar Using Phase-Coded Waveform

In the example in “End-to-End Radar System”, you can use a phase-coded waveform in place of a rectangular waveform. To do so:

- 1 Replace the definition of `hwav` with the following definition.

```
hwav = phased.PhaseCodedWaveform('Type','Frank','NumChips',4,...  
    'ChipWidth',1e-6,'PRF',5e3,'OutputFormat','Pulses',...  
    'NumPulses',1);
```

- 2 Redefine the pulse width, `tau`, based on the properties of the new waveform.

```
tau = hwav.ChipWidth * hwav.NumChips;
```

For convenience, the complete code appears here. For a detailed explanation of the code, see the original example, “End-to-End Radar System”.

```
hwav = phased.PhaseCodedWaveform('Type','Frank','NumChips',4,...  
    'ChipWidth',1e-6,'PRF',5e3,'OutputFormat','Pulses',...  
    'NumPulses',1);
```

```
hant = phased.IsotropicAntennaElement('FrequencyRange',...  
    [1e9 10e9]);
```

```
htgt = phased.RadarTarget('Model','Nonfluctuating',...  
    'PulseRepetitionFrequency',5e3);
```

```

        'MeanRCS',0.5,'PropagationSpeed',physconst('LightSpeed'),...
        'OperatingFrequency',4e9);

htxplat = phased.Platform('InitialPosition',[0;0;0],...
    'Velocity',[0;0;0],'OrientationAxes',[1 0 0;0 1 0;0 0 1]);
htgtplat = phased.Platform('InitialPosition',[7000; 5000; 0],...
    'Velocity',[-15;-10;0]);

[tgtrng,tgtang] = rangeangle(htgtplat.InitialPosition,...
    htxplat.InitialPosition);

Pd = 0.9;
Pfa = 1e-6;
numpulses = 10;
SNR = albersheim(Pd,Pfa,10);

maxrange = 1.5e4;
lambda = physconst('LightSpeed')/4e9;
tau = hwav.ChipWidth * hwav.NumChips;
Pt = radareqpow(lambda,maxrange,SNR,tau,'RCS',0.5,'Gain',20);

htx = phased.Transmitter('PeakPower',50e3,'Gain',20,...
    'LossFactor',0,'InUseOutputPort',true,...
    'CoherentOnTransmit',true);

hrad = phased.Radiator('Sensor',hant,...
    'PropagationSpeed',physconst('LightSpeed'),...
    'OperatingFrequency',4e9);
hcol = phased.Collector('Sensor',hant,...
    'PropagationSpeed',physconst('LightSpeed'),...
    'Wavefront','Plane','OperatingFrequency',4e9);

hrec = phased.ReceiverPreamp('Gain',20,'NoiseFigure',2,...
    'ReferenceTemperature',290,'SampleRate',1e6,...
    'EnableInputPort',true,'SeedSource','Property','Seed',1e3);

hspace = phased.FreeSpace(...
    'PropagationSpeed',physconst('LightSpeed'),...
    'OperatingFrequency',4e9,'TwoWayPropagation',false,...
    'SampleRate',1e6);

```

```

% Time step between pulses
T = 1/hwav.PRF;
% Get antenna position
txpos = htxplat.InitialPosition;
% Allocate array for received echoes
rxsig = zeros(hwav.SampleRate*T, numpulses);

for n = 1:numpulses
    % Update the target position
    [tgtpos, tgtvel] = step(htgtplat, T);
    % Get the range and angle to the target
    [tgtrng, tgtang] = rangeangle(tgtpos, txpos);
    % Generate the pulse
    sig = step(hwav);
    % Transmit the pulse. Output transmitter status
    [sig, txstatus] = step(htx, sig);
    % Radiate the pulse toward the target
    sig = step(hrad, sig, tgtang);
    % Propagate the pulse to the target in free space
    sig = step(hspace, sig, txpos, tgtpos, [0;0;0], tgtvel);
    % Reflect the pulse off the target
    sig = step(htgt, sig);
    % Propagate the echo to the antenna in free space
    sig = step(hspace, sig, tgtpos, txpos, tgtvel, [0;0;0]);
    % Collect the echo from the incident angle at the antenna
    sig = step(hcol, sig, tgtang);
    % Receive the echo at the antenna when not transmitting
    rxsig(:, n) = step(hrec, sig, ~txstatus);
end

rxsig = pulsint(rxsig, 'noncoherent');
t = unigrid(0, 1/hrec.SampleRate, T, '[]');
rangegates = (physconst('LightSpeed')*t)/2;
plot(rangegates, rxsig); hold on;
xlabel('Meters'); ylabel('Power');
ylim = get(gca, 'YLim');
plot([tgtrng, tgtrng], [0 ylim(2)], 'r');

```

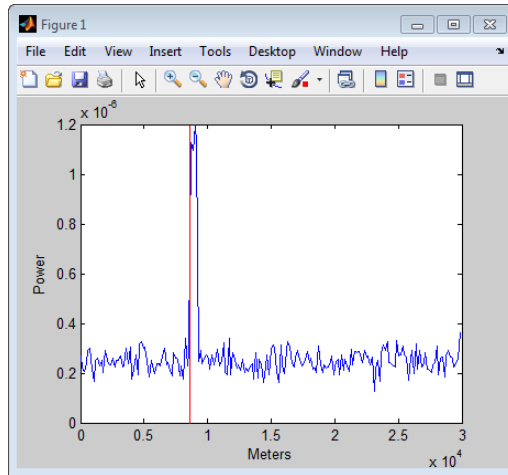
Waveforms with Staggered PRFs

In this section...

“When to Use Staggered PRFs” on page 4-24

“Linear FM Waveform with Staggered PRF” on page 4-24

When to Use Staggered PRFs

Using a nonconstant PRF has important applications in radar. This approach is called *PRF staggering*, or *PRI staggering*.

Uses of staggered PRFs include:

- The removal of Doppler ambiguities, or *blind speeds*, where Doppler frequencies that are multiples of the PRF are aliased to zero
- Mitigation of the effects of jamming

To implement a staggered PRF, configure your waveform object with a vector instead of a scalar as the PRF property value.

Linear FM Waveform with Staggered PRF

Model a linear FM pulse waveform with two PRFs, 1 and 2 kHz. Use a linear FM pulse with a sweep bandwidth of 200 kHz and a duration of 100 μ s. The sample rate is 1 MHz. Output 5 pulses.

```
prfs = [1e3 2e3];
hfm = phased.LinearFMWaveform('PRF',prfs,...
    'SweepBandwidth',200e3,...
    'PulseWidth',100e-6,'NumPulses',5);
wf = step(hfm);
T = length(wf)*(1/hfm.SampleRate);
t = unigrid(0,1/hfm.SampleRate,T,'[]');
plot(t.*1000,real(wf))
set(gca,'xtick',[0 1 1.5 2.5 3]);
xlabel('milliseconds');
```

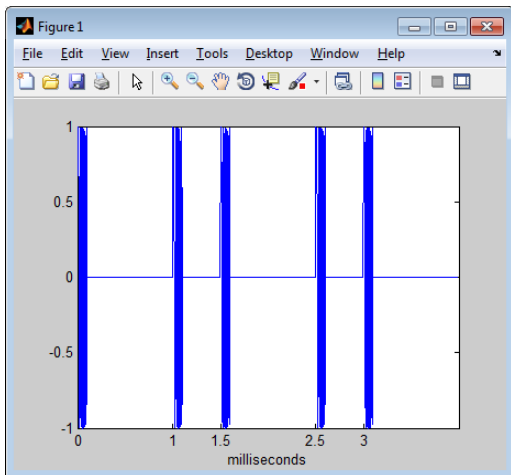

Transmitter

In this section...

“Transmitter Object” on page 4-26

“Phase Noise” on page 4-28

Transmitter Object

The `phased.Transmitter` object enables you to model key components of the *radar equation* including the peak transmit power, the transmit gain, and a system loss factor. You can use `phased.Transmitter` together with `radareqpow`, `radareqrng`, and `radareqsnr`, to relate the received echo power to your transmitter specifications.

While the preceding functionality is important in applications dependent on amplitude such as signal detectability, Doppler processing depends on the phase of the complex envelope. In order to accurately estimate the radial velocity of moving targets, it is important that the radar operates in either a *fully coherent* or *pseudo-coherent* mode. In the fully coherent, or *coherent on transmit*, mode, the phase of the transmitted pulses is constant. Constant phase provides you with a reference to detect Doppler shifts.

A transmitter that applies a random phase to each pulse creates *phase noise* that can obscure Doppler shifts. If the components of the radar do not enable you to maintain constant phase, you can create a pseudo-coherent, or *coherent on receive* radar by keeping a record of the random phase errors introduced by the transmitter. The receiver can correct for these errors by modulation of the complex envelope. The `phased.Transmitter` object enables you to model both coherent on transmit and coherent on receive behavior.

The transmitter object has the following modifiable properties:

- `PeakPower` — Peak transmit power in watts
- `Gain` — Transmit gain in decibels
- `LossFactor` — Loss factor in decibels
- `InUseOutputPort` — Track transmitter’s status. Setting this property to true outputs a vector of 1s and 0s indicating when transmitter is on and

off. In a monostatic radar, the transmitter and receiver cannot operate simultaneously.

- `CoherentOnTransmit` — Preserve *coherence* among transmitter pulses. Setting this property to `true` (the default) models the operation of a fully coherent transmitter where the pulse-to-pulse phase is constant. Setting this property to `false` introduces random phase noise from pulse to pulse and models the operation of a non-coherent transmitter.
- `PhaseNoiseOutputPort` — Output the random pulse phases introduced by non-coherent operation of the transmitter. This property only applies if the `CoherentOnTransmit` property is `false`. By keeping a record of the random pulse phases, you can create a *pseudo-coherent*, or *coherent on receive* radar.

Construct a transmitter with a peak transmit power of 1000 watts, a transmit gain of 20 decibels (dB), and a loss factor of 0 dB. Set the `InUseOutputPort` property to `true` to record the transmitter's status.

```
htx = phased.Transmitter('PeakPower',1e3,'Gain',20,...
    'LossFactor',0,'InUseOutputPort',true)
```

Construct a pulse waveform for transmission. In this example, use a 100-microsecond linear FM pulse with a bandwidth of 200 kHz. Use the default sweep direction and sample rate. Set the PRF to 2 kHz.

```
hpuls = phased.LinearFMWaveform('PulseWidth',100e-6,'PRF',2e3,...
    'SweepBandwidth',2e5,'OutputFormat','Pulses','NumPulses',1);
```

Obtain the pulse waveform using the `step` method of the waveform object. Transmit the waveform using the `step` method of the transmitter object, `hpuls`. The output is one pulse repetition interval because the `NumPulses` property of the waveform object is equal to 1. The pulse waveform values are scaled based on the peak transmit power and the ratio of the transmitter gain to loss factor. The scaling factor is $\sqrt{\text{htx.PeakPower} \cdot \text{db2pow}(\text{htx.Gain} - \text{htx.LossFactor})}$.

```
wf = step(hpuls);
[txoutput,txstatus] = step(htx,wf);
t = unigrid(0,1/hpuls.SampleRate,1/hpuls.PRF,[]);
subplot(211)
plot(t,real(txoutput));
axis tight; grid on; ylabel('Amplitude');
```

```

title('Transmitter Output (real part) - One PRI');
subplot(212)
plot(t,txstatus);
axis([0 t(end) 0 1.5]); xlabel('Seconds'); grid on;
ylabel('Off-On Status');
set(gca,'ytick',[0 1]);
title('Transmitter Status');

```

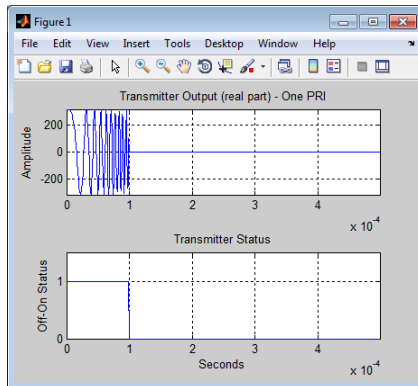

Phase Noise

To model a coherent on receive radar, you can set the `CoherentOnTransmit` property to `false` and the `PhaseNoiseOutputPort` property to `true`. You can output the random phase added to each sample with `step`.

To illustrate this process, the following example uses a rectangular pulse waveform with five pulses. A random phase is added to each sample of the waveform. Compute the phase of the output waveform and compare the phase to the phase noise returned by the `step` method.

For convenience, set the gain of the transmitter to 0 dB, the peak power to 1 W, and seed the random number generator to ensure reproducible results.

```

hrect = phased.RectangularWaveform('NumPulses',5);
htx = phased.Transmitter('CoherentOnTransmit',false,...
    'PhaseNoiseOutputPort',true,'Gain',0,'PeakPower',1,...
    'SeedSource','Property','Seed',1000);
wf = step(hrect);

```

```
[txtoutput,phnoise] = step(htx,wf);
phdeg = radtodeg(phnoise);
phdeg(phdeg>180)= phdeg(phdeg>180)-360;
plot(wf); title('Input Waveform');
axis([0 length(wf) 0 1.5]); ylabel('Amplitude');
grid on;
figure;
subplot(2,1,1)
plot(radtodeg(atan2(imag(txtoutput),real(txtoutput))))
title('Phase of the Output'); ylabel('Degrees');
axis([0 length(wf) -180 180]); grid on;
subplot(2,1,2)
plot(phdeg); title('Phase Noise'); ylabel('Degrees');
axis([0 length(wf) -180 180]); grid on;
```

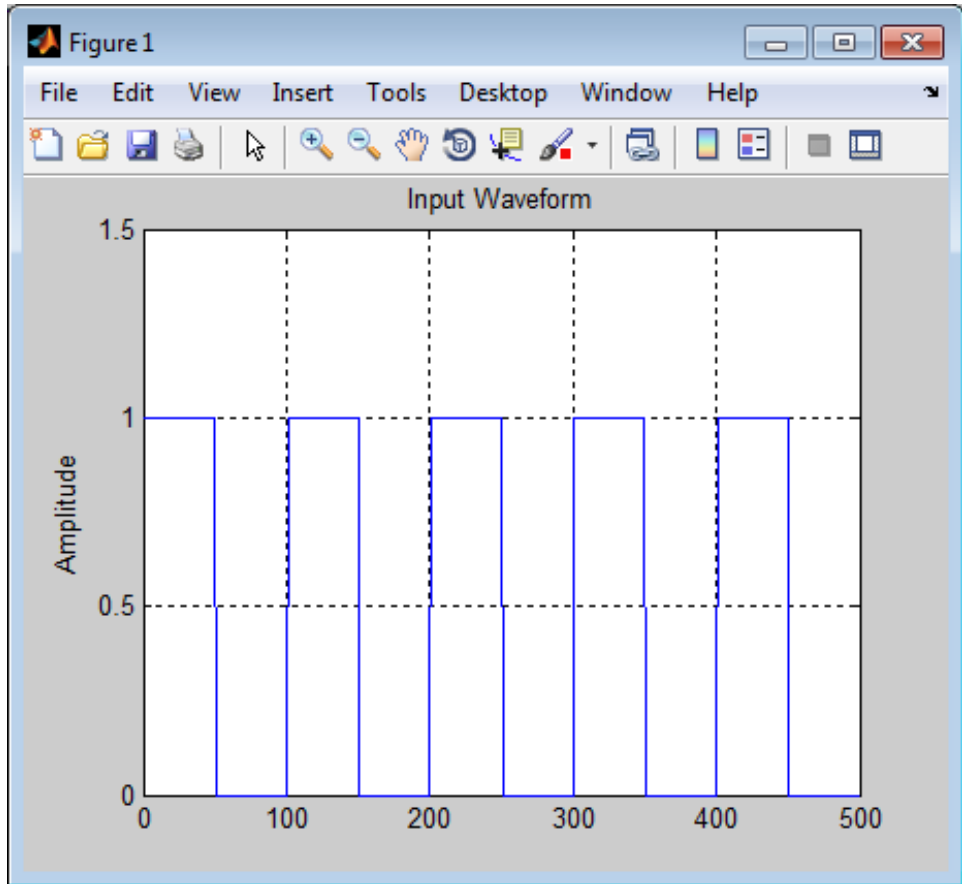

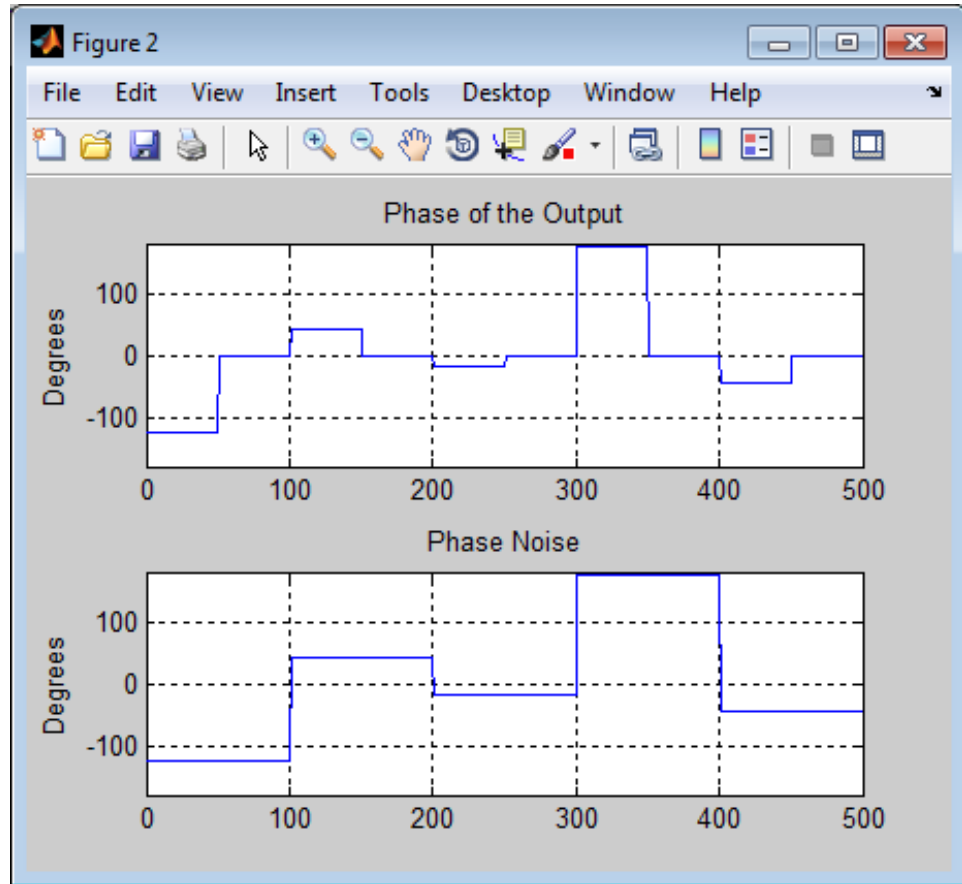

The first figure shows the waveform. The phase of each pulse at the input to the transmitter is zero. In the second figure, the top plot shows the phase of the transmitter output waveform. The bottom plot shows the phase added to each sample. Focus on the first 100 samples. The pulse waveform is equal to 1 for samples 1–50 and 0 for samples 51–100. The added random phase is a constant -124.7 degrees for samples 1–100, but this affects the output only when the pulse waveform is nonzero. In the output waveform, you see that the output waveform has a phase of -124.7 degrees for samples 1–50 and 0 for 51–100. Examining the transmitter output and phase noise for samples where the input waveform is nonzero, you see that the phase output of step and the phase of the transmitter output agree.

Receiver Preamp

In this section...

“Operation of Receiver Preamp” on page 4-32

“Configuring Receiver Preamp” on page 4-32

“Model Receiver Effects on Sinusoidal Input” on page 4-34

“Model Coherent on Receive Behavior” on page 4-35

Operation of Receiver Preamp

The `phased.ReceiverPreamp` object enables you to model the effects of gain and component-based noise on the signal-to-noise ratio (SNR) of received signals. `phased.ReceiverPreamp` operates on baseband signals. The object is not intended to model system effects at RF or intermediate frequency (IF) stages.

Configuring Receiver Preamp

The `phased.ReceiverPreamp` object has the following modifiable properties:

- `EnableInputPort` — A logical property that enables you to specify when the receiver is on or off. Input the actual status of the receiver as a vector to `step`. This property is useful when modeling a monostatic radar system. In a monostatic radar, it is important to ensure the transmitter and receiver are not operating simultaneously. See `phased.Transmitter` and “Transmitter” on page 4-26.
- `Gain` — Gain in dB
- `LossFactor` — Loss factor in dB.
- `NoiseBandwidth` — Bandwidth of the noise spectrum in Hz
- `NoiseFigure` — Receiver noise figure in dB
- `ReferenceTemperature` — Reference temperature of the receiver in kelvin
- `EnableInputPort` — Add input to specify when the receiver is active
- `PhaseNoiseInputPort` — Add input to specify phase noise for coherent on receive receiver

- `SeedSource` — Enables you to specify the seed of the random number generator

The noise figure is a dimensionless quantity that indicates how much a receiver deviates from an ideal receiver in terms of internal noise. An ideal receiver only produces the expected thermal noise power for a given noise bandwidth and temperature. A noise figure of 1 indicates that the noise power of a receiver equals the noise power of an ideal receiver. Because an actual receiver cannot exhibit a noise power value less than an ideal receiver, the noise figure is always greater than or equal to one. In decibels, the noise figure must be nonnegative.

To model the effect of the receiver preamp on the signal, `phased.ReceiverPreamp` computes the *effective system noise temperature* by taking the product of the reference temperature and the noise figure converted to a power measurement with `db2pow`. See `systemtemp` for details.

`phased.ReceiverPreamp` computes the noise power as the product of the Boltzmann constant, the effective system noise temperature, and the noise bandwidth.

The additive noise for the receiver is modeled as a zero-mean complex white Gaussian noise vector with variance equal to the noise power. The real and imaginary parts of the noise vector each have variance equal to 1/2 the noise power.

The signal is scaled by the ratio of the receiver gain to the loss factor expressed as a power ratio. If you express the gain and loss factor as powers by G and L respectively and the noise power as σ^2 , the output is equal to :

$$y[n] = \frac{G}{L} x[n] + \frac{\sigma}{\sqrt{2}} w[n]$$

where $x[n]$ is the complex-valued input signal and $w[n]$ is a zero-mean complex white Gaussian noise sequence.

Model Receiver Effects on Sinusoidal Input

Specify a `phased.ReceiverPreamp` object with a gain of 20 dB, a noise bandwidth of 1 MHz, a noise figure of 0 dB, and a reference temperature of 290 kelvin.

```
hr = phased.ReceiverPreamp('Gain',20,'NoiseBandwidth',1e6,...
    'NoiseFigure',0,'ReferenceTemperature',290,...
    'SampleRate',1e6,'SeedSource','Property','Seed',1e3);
```

Assume a 100-Hz sine wave input with an amplitude of 1 microvolt. Because the Phased Array System Toolbox assumes all modeling is done in the baseband, use a complex exponential as the input to the `step` method.

```
t = unigrid(0,0.001,0.1,[]);
x = 1e-6*exp(1j*2*pi*100*t).';
y = step(hr,x);
```

The output of the `step` method is complex-valued as expected. To demonstrate how this output is produced, the noise power is equal to:

```
noisepow = physconst('Boltzmann')*...
    systemp(0,hr.ReferenceTemperature)*hr.NoiseBandwidth;
```

The noise power is the variance of the additive white noise.

To determine the correct amplitude scaling of the input signal, note that the gain is 20 dB. Because the loss factor in this case is 0 dB, the scaling factor for the input signal is found by solving the following equation for G :

$$10\log_{10}(G^2) = 20$$

The scaling factor is 10. You can scale the input signal by a factor of ten and add complex white Gaussian noise with the appropriate variance to produce an output equivalent to the preceding call to `step`. The following code assumes that the noise bandwidth equals the sample rate of the receiver preamp.

```
rng(1e3);
y1 = 10*x + sqrt(noisepow/2) * ...
    (randn(size(x))+1j*randn(size(x)));
```

Compare `y` to `y1`.

Model Coherent on Receive Behavior

To model a coherent on receive monostatic radar use the `EnableInputPort` and `PhaseNoiseInputPort` properties. In a monostatic radar, the transmitter and receiver cannot operate simultaneously. Therefore, it is important to keep track of when the transmitter is active so that you can disable the receiver at those times. You can input a record of when the transmitter is active by setting the `EnableInputPort` to `true` and providing this record to the `step` method.

In a coherent on receive radar, the receiver corrects for the phase noise introduced at the transmitter by using the record of those phase errors. You can input a record of the transmitter phase errors to `step` when you set the `PhaseNoiseInputPort` property to `true`.

To illustrate this, construct a rectangular pulse waveform with five pulses. The PRF is 10 kHz and the pulse width is 50 μ s. The PRI is exactly two times the pulse width so the transmitter alternates between active and inactive time intervals of the same duration. For convenience, set the gains on both the transmitter and receiver to 0 dB and the peak power on the transmitter to 1 watt.

Use the `PhaseNoiseOutputPort` and `InUseOutputPort` properties on the transmitter to record the phase noise and the status of the transmitter.

Enable the `EnableInputPort` and `PhaseNoiseInputPort` properties on the receiver preamp to determine when the receiver is active and to correct for the phase noise introduced at the transmitter.

Delay the output of the transmitter using `delayseq` to simulate the waveform arriving at the receiver preamp when the transmitter is inactive and the receiver is active.

```
hrect = phased.RectangularWaveform('NumPulses',5);
htx = phased.Transmitter('CoherentOnTransmit',false,...
    'PhaseNoiseOutputPort',true,'Gain',0,'PeakPower',1,...
    'SeedSource','Property','Seed',1000,'InUseOutputPort',true);
wf = step(hrect);
[txtoutput,txstatus,phnoise] = step(htx,wf);
txtoutput = delayseq(txtoutput,hrect.PulseWidth,...
    hrect.SampleRate);
```

```
hrc = phased.ReceiverPreamp('Gain',0,...  
    'PhaseNoiseInputPort',true,'EnableInputPort',true);  
y = step(hrc,txtoutput,~txstatus,phnoise);  
subplot(2,1,1)  
plot(real(txtoutput));  
title('Delayed Transmitter Output with Phase Noise');  
ylabel('Amplitude');  
subplot(2,1,2)  
plot(real(y));  
xlabel('Samples'); ylabel('Amplitude');  
title('Received Signal with Phase Correction');
```

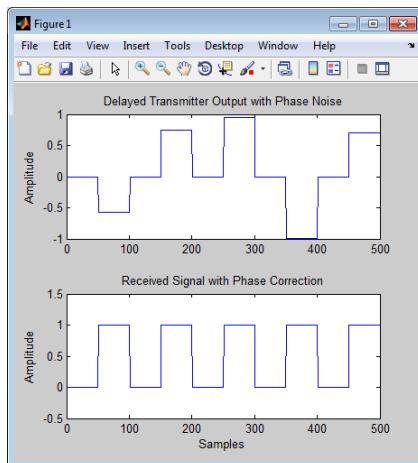

Radar Equation

In this section...

“Radar Equation Theory” on page 4-37

“Link Budget Calculation Using the Radar Equation” on page 4-39

“Maximum Detectable Range for a Monostatic Radar” on page 4-39

“Output SNR at the Receiver in a Bistatic Radar” on page 4-40

Radar Equation Theory

The point target radar range equation estimates the power at the input to the receiver for a target of a given radar cross section at a specified range. In this equation, the signal model is assumed to be deterministic. The equation for the power at the input to the receiver is:

$$P_r = \frac{P_t G_t G_r \lambda^2 \sigma}{(4\pi)^3 R_t^2 R_r^2 L}$$

where the terms in the equation are:

- P_r — Received power in watts.
- P_t — Peak transmit power in watts.
- G_t — Transmitter gain in decibels.
- G_r — Receiver gain in decibels.
- λ — Radar operating frequency wavelength in meters.
- σ — Target’s nonfluctuating radar cross section in square meters.
- L — General loss factor in decibels that accounts for both system and propagation loss.
- R_t — Range from the transmitter to the target.
- R_r — Range from the receiver to the target. If the radar is monostatic, the transmitter and receiver ranges are identical.

The equation for the power at the input to the receiver represents the signal term in the signal-to-noise (SNR) ratio. To model the noise term, assume the thermal noise in the receiver has a white noise power spectral density (PSD) given by:

$$P(f) = kT$$

where k is the Boltzmann constant and T is the effective noise temperature. The receiver acts as a filter to shape the white noise PSD. Assume that the magnitude squared receiver frequency response approximates a rectangular filter with bandwidth equal to the reciprocal of the pulse duration, $1/\tau$. The total noise power at the output of the receiver is:

$$N = \frac{kTF_n}{\tau}$$

where F_n is the receiver *noise figure*.

The product of the effective noise temperature and the receiver noise factor is referred to as the *system temperature* and is denoted by T_s , so that $T_s = TF_n$.

Using the equation for the received signal power and the output noise power, the receiver output SNR is:

$$\frac{P_r}{N} = \frac{P_t \tau G_t G_r \lambda^2 \sigma}{(4\pi)^3 k T_s R_t^2 R_r^2 L}$$

Solving for the required peak transmit power:

$$P_t = \frac{P_r (4\pi)^3 k T_s R_t^2 R_r^2 L}{N \tau G_t G_r \lambda^2 \sigma}$$

The preceding equations are implemented in the Phased Array System Toolbox by the functions: `radareqpow`, `radareqrng`, and `radareqsnr`. These functions and the equations on which they are based are valuable tools in radar system design and analysis.

Link Budget Calculation Using the Radar Equation

This example shows how to compute the required peak transmit power using the radar equation. You implement a noncoherent detector with a monostatic radar operating at 5 GHz. Based on the noncoherent integration of ten one-microsecond pulses, you want to achieve a detection probability of 0.9 with a maximum false-alarm probability of 10^{-6} for a target with a nonfluctuating radar cross section (RCS) of 1 m^2 at 30 km. The transmitter gain is 30 dB. Determine the required SNR at the receiver and use the radar equation to calculate the required peak transmit power.

Use Albersheim's equation to determine the required SNR for the specified detection and false-alarm probabilities.

```
Pd = 0.9;
Pfa = 1e-6;
NumPulses = 10;
SNR = albersheim(Pd,Pfa,10)
```

The required SNR is approximately 5 dB. Use the function `radareqpow` to determine the required peak transmit power in watts.

```
tgrng = 30e3; % target range in meters
lambda = 3e8/5e9; % wavelength of the operating frequency
RCS = 1; % target RCS
pulsedur = 1e-6; % pulse duration
G = 30; % transmitter and receiver gain (monostatic radar)
Pt = radareqpow(lambda,tgrng,SNR,pulsedur,'rcs',RCS,'gain',G)
```

The required peak power is approximately 5.6 kW.

Maximum Detectable Range for a Monostatic Radar

Assume that the minimum detectable SNR at the receiver of a monostatic radar operating at 1 GHz is 13 dB. Use the radar equation to determine the maximum detectable range for a target with a nonfluctuating RCS of 0.5 m^2 if the radar has a peak transmit power of 1 MW. Assume the transmitter gain is 40 dB and the radar transmits a pulse that is $0.5 \mu\text{s}$ in duration.

```
tau = 0.5e-6; % pulse duration
G = 40; % transmitter and receiver gain (monostatic radar)
RCS = 0.5; % target RCS
```

```
Pt = 1e6; %peak transmit power in watts
lambda = 3e8/1e9;
SNR = 13; % required SNR in dB
maxrng = radareqrng(lambda,SNR,Pt,tau,'rcs',RCS,'gain',G)
```

The maximum detectable range is approximately 345 km.

Output SNR at the Receiver in a Bistatic Radar

Estimate the output SNR for a target with an RCS of 1 m^2 . The radar is bistatic. The target is located 50 km from the transmitter and 75 km from the receiver. The radar operating frequency is 10 GHz. The transmitter has a peak transmit power of 1 MW with a gain of 40 dB. The pulse width is 1 μs . The receiver gain is 20 dB.

```
lambda = physconst('LightSpeed')/10e9;
tau = 1e-6;
Pt = 1e6;
TxRvRng =[50e3 75e3];
Gain = [40 20];
snr = radareqsnr(lambda,TxRvRng,Pt,tau,'Gain',Gain);
```

The estimated SNR is approximately 9 dB.

Beamforming

- “Conventional Beamforming” on page 5-2
- “Adaptive Beamforming” on page 5-7
- “Wideband Beamforming” on page 5-11

Conventional Beamforming

In this section...

“Uses for Beamformers” on page 5-2

“Support for Conventional Beamforming” on page 5-2

“Narrowband Phase Shift Beamformer with a ULA” on page 5-2

Uses for Beamformers

You can use a beamformer to spatially filter the arriving signals. Accentuating or attenuating signals that arrive from specific directions helps you distinguish between signals of interest and interfering signals from other directions.

Support for Conventional Beamforming

You can implement a narrowband phase shift beamformer using `phased.PhaseShiftBeamformer`. When you use this object, you must specify these aspects of the situation you are simulating:

- Sensor array
- Signal propagation speed
- System operating frequency
- Beamforming direction

For wideband beamformers, see “Wideband Beamforming” on page 5-11.

Narrowband Phase Shift Beamformer with a ULA

Construct a ULA with 10 elements. Assume the carrier frequency is 1 GHz and set the array element spacing to be one-half the carrier frequency wavelength.

```
fc = 1e9;  
lambda = physconst('LightSpeed')/fc;  
hula = phased.ULA('NumElements',10,'ElementSpacing',lambda/2);
```

The ULA sensors are isotropic antenna elements (see `phased.IsotropicAntennaElement`). Set the frequency range of the antenna elements to position the carrier frequency in the middle of the operating range.

```
hula.Element.FrequencyRange = [8e8 1.2e9];
```

Simulate a test signal. For this example, use a simple rectangular pulse.

```
t = linspace(0,0.3,300)';
testsig = zeros(size(t));
testsig(201:205) = 1;
```

Assume the rectangular pulse is incident on the ULA from an angle of 30 degrees azimuth and 0 degrees elevation. Use the `collectPlaneWave` method of the ULA object to simulate reception of the pulse waveform from the specified angle.

```
angle_of_arrival = [30;0];
x = collectPlaneWave(hula,testsig,angle_of_arrival,fc);
```

`x` is a matrix with ten columns. Each column represents the received signal at one of the array elements.

Corrupt the columns of `x` with complex-valued Gaussian noise. Reset the default random number stream for reproducible results. Plot the magnitudes of the received pulses at the first four elements of the ULA.

```
rng default
npower = 0.5;
x = x + sqrt(npower/2)*(randn(size(x))+1i*randn(size(x)));
subplot(221)
plot(t,abs(x(:,1))); title('Element 1 (magnitude)');
axis tight; ylabel('Magnitude');
subplot(222)
plot(t,abs(x(:,2))); title('Element 2 (magnitude)');
axis tight; ylabel('Magnitude');
subplot(223)
plot(t,abs(x(:,3))); title('Element 3 (magnitude)');
axis tight; xlabel('Seconds'); ylabel('Magnitude');
subplot(224)
```

```
plot(t,abs(x(:,4))); title('Element 4 (magnitude)');
axis tight; xlabel('Seconds'); ylabel('Magnitude');
```

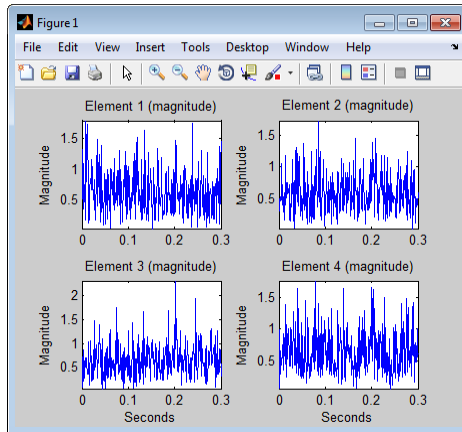

Construct your phase-shift beamformer. Set the `WeightsOutputPort` property to `true` to output the spatial filter weights.

```
hbf = phased.PhaseShiftBeamformer('SensorArray',hula,...
    'OperatingFrequency',1e9,'Direction',angle_of_arrival,...
    'WeightsOutputPort',true);
```

Apply the `step` method for the phase shift beamformer. The `step` method computes and applies the correct weights for the specified angle. The phase-shifted outputs from the ten array elements are then summed.

```
[y,w] = step(hbf,x);
```

Plot the magnitude of the output waveform along with the original waveform for comparison.

```
figure;
subplot(211)
plot(t,abs(testsig)); axis tight;
title('Original Signal'); ylabel('Magnitude');
subplot(212)
plot(t,abs(y)); axis tight;
title('Received Signal with Beamforming');
ylabel('Magnitude'); xlabel('Seconds');
```

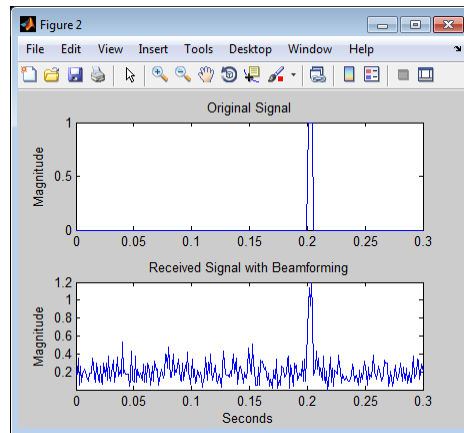

To examine the effect of the beamforming weights on the array response, plot the array normalized power response both with—and without—the beamforming weights.

```

azang = -180:30:180;
figure;
subplot(211)
plotResponse(hula,fc,physconst('LightSpeed'));
set(gca,'xtick',azang);
title('Array Response without Beamforming Weights');
subplot(212)
plotResponse(hula,fc,physconst('LightSpeed'),'weights',w);
set(gca,'xtick',azang);
title('Array Response with Beamforming Weights');

```

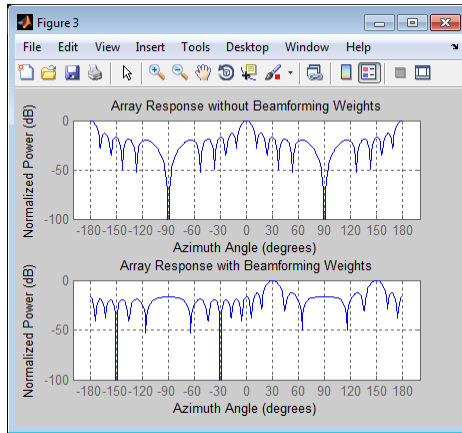

Adaptive Beamforming

In this section...

“Benefits of Adaptive Beamforming” on page 5-7

“Support for Adaptive Beamforming” on page 5-7

“LCMV Beamformer” on page 5-7

Benefits of Adaptive Beamforming

“Narrowband Phase Shift Beamformer with a ULA” on page 5-2 uses weights chosen independent of any data received by the array. The weights in the narrowband phase shift beamformer steer the array response in a specified direction. However, they do not account for any interference scenarios. As a result, these conventional beamformers are susceptible to interference signals. Such interference signals can be a particular problem if they occur at sidelobes of the array response.

By contrast, adaptive, or statistically optimum, beamformers can account for interference signals. An *adaptive beamformer* algorithm chooses the weights based on the statistics of the received data. For example, an adaptive beamformer can improve the SNR by using the received data to place nulls in the array response. These nulls are placed at angles corresponding to the interference signals.

Support for Adaptive Beamforming

Phased Array System Toolbox software provides these adaptive beamformers:

- Linearly constrained minimum variance (LCMV) beamformers
- Minimum variance distortionless response (MVDR) beamformers
- Frost beamformers

LCMV Beamformer

This example uses code from the “Narrowband Phase Shift Beamformer with a ULA” on page 5-2 example. Execute the code from that example before you run this example.

Use `phased.BarrageJammer` as the interference source. Specify the barrage jammer to have an effective radiated power of 10 W. The interference signal from the barrage jammer is incident on the ULA at an angle of 120 degrees azimuth and 0 degrees elevation.

```
hjammer = phased.BarrageJammer('ERP',10,'SamplesPerFrame',300);
jamsig = step(hjammer);
jammer_angle = [120;0];
jamsig = collectPlaneWave(hula,jamsig,jammer_angle,fc);
```

Add some low-level complex white Gaussian noise to simulate noise contributions not directly associated with the jamming signal. Seed the random number generator for reproducible results.

```
noisePwr = 0.00001; % noise power, 50dB SNR
rng(2008);
noise = sqrt(noisePwr/2)*...
    (randn(size(jamsig))+1j*randn(size(jamsig)));
jamsig = jamsig+noise;
rxsig = x+jamsig;
[yout,w] = step(hbf,rxsig);
```

Implement the LCMV beamformer. Use the target-free data, `jamsig`, as training data. Output the beamformer weights.

```
hstv = phased.SteeringVector('SensorArray',hula,...
    'PropagationSpeed',physconst('LightSpeed'));
hLCMV = phased.LCMVBeamformer('DesiredResponse',1,...
    'TrainingInputPort',true,'WeightsOutputPort',true);
hLCMV.Constraint = step(hstv,fc,angle_of_arrival);
hLCMV.DesiredResponse = 1;
[yLCMV,wLCMV] = step(hLCMV,rxsig,jamsig);
subplot(211)
plot(t,abs(yout)); axis tight;
title('Conventional Beamformer');
ylabel('Magnitude');
subplot(212);
plot(t,abs(yLCMV)); axis tight;
title('LCMV (Adaptive) Beamformer');
xlabel('Seconds'); ylabel('Magnitude');
```

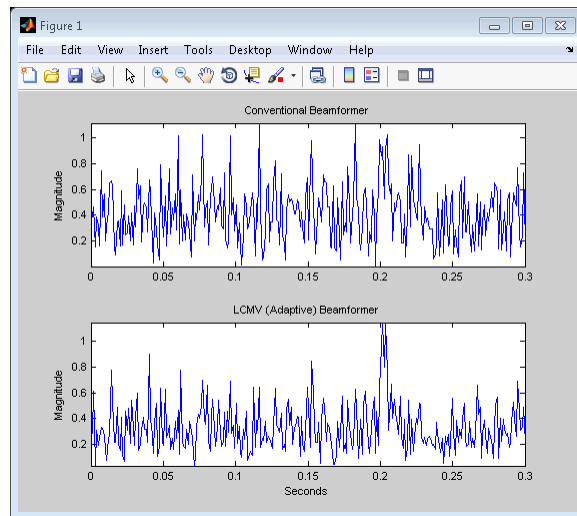

The adaptive beamformer significantly improves the SNR of the rectangular pulse at 0.2 s.

Plot the array normalized power response for the conventional and LCMV beamformers.

```
figure;
subplot(211)
plotResponse(hu1a,fc,physconst('LightSpeed'),'weights',w);
title('Array Response with Conventional Beamforming Weights');
subplot(212)
plotResponse(hu1a,fc,physconst('LightSpeed'),'weights',wLCMV);
title('Array Response with LCMV Beamforming Weights');
```

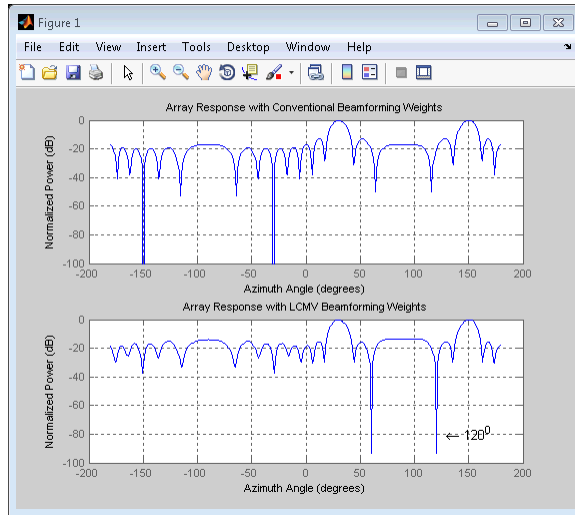

The LCMV beamforming weights place a null in the array response at the arrival angle of the interference signal.

See Also

`phased.FrostBeamformer` | `phased.LCMVBeamformer` |
`phased.MVDRBeamformer` |

Related Examples

- Conventional and Adaptive Beamformers

Wideband Beamforming

In this section...

“Support for Wideband Beamforming” on page 5-11

“Time-Delay Beamforming” on page 5-11

“Visualization of Wideband Beamformer Performance” on page 5-13

Support for Wideband Beamforming

Beamforming achieved by multiplying the sensor input by a complex exponential with the appropriate phase shift only applies for narrowband signals. In the case of wideband, or *broadband*, signals, the steering vector is not a function of a single frequency.

Phased Array System Toolbox software provides conventional and adaptive wideband beamformers. They include:

- `phased.FrostBeamformer`
- `phased.SubbandPhaseShiftBeamformer`
- `phased.TimeDelayBeamformer`
- `phased.TimeDelayLCMVBeamformer`

Time-Delay Beamforming

This example shows how to perform wideband conventional time-delay beamforming with a microphone array.

Create an acoustic (pressure wave) chirp signal. The chirp signal has a bandwidth of 1 kHz and propagates at a speed of 340 m/s at sea level.

```
c = 340; % speed of sound at sea level
t = linspace(0,1,5e4)';
sig = chirp(t,0,1,1e3);
```

Collect the acoustic chirp with a ten-element ULA. Use omnidirectional microphone elements spaced less than one-half the wavelength of the 50 kHz

sampling frequency. The chirp is incident on the ULA with an angle of 45 degrees azimuth and 0 degrees elevation.

```
hmic = phased.OmnidirectionalMicrophoneElement(...
    'FrequencyRange',[20 20e3]);
hula = phased.ULA('Element',hmic,'NumElements',10,...
    'ElementSpacing',0.01);
hcol = phased.WidebandCollector('Sensor',hula,'SampleRate',5e4,...
    'PropagationSpeed',c,'ModulatedInput',false);
sigang = [60; 0];
rsig = step(hcol,sig,sigang);
rsig = rsig+0.3*randn(size(rsig));
```

Apply a wideband conventional time-delay beamformer to improve the SNR of the received signal.

```
htbf = phased.TimeDelayBeamformer('SensorArray',hula,...
    'SampleRate',5e4,'PropagationSpeed',c,'Direction',sigang);
y = step(htbf,rsig);
subplot(2,1,1);
plot(t(1:5e3),real(rsig(1:5e3,5)));
title('Signal (real part) at the 5th element of the ULA');
subplot(2,1,2);
plot(t(1:5e3),real(y(1:5e3)));
title('Signal (real part) with time-delay beamforming');
xlabel('Seconds');
```

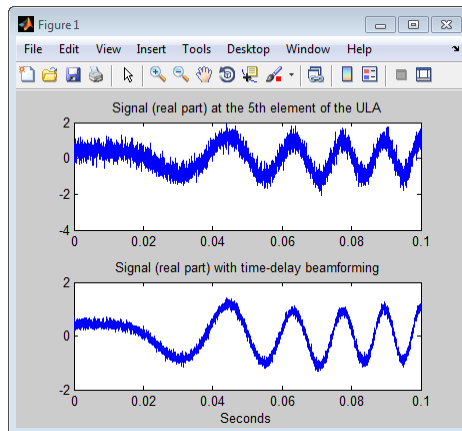

See [Acoustic Beamforming Using a Microphone Array](#) for an example of using wideband beamforming to extract speech signals in noise.

Visualization of Wideband Beamformer Performance

This example shows how to plot the response of an antenna element and an array, to help validate the performance of a beamformer. The array must maintain an acceptable array pattern throughout the bandwidth.

Create a uniform linear array of cosine antenna elements.

```
c = 340;
freq = [1e3 2.75e3];
fc = 2e3;
numels = 11;
h = phased.CosineAntennaElement('FrequencyRange',freq);
ha = phased.ULA('NumElements',numels,...
    'ElementSpacing',0.5*c/fc,'Element',h);
```

Plot the response pattern of the antenna element over a series of frequencies.

```
plotFreq = linspace(min(freq),max(freq),15);
figure;
plotResponse(h,plotFreq,'OverlayFreq',false);
```

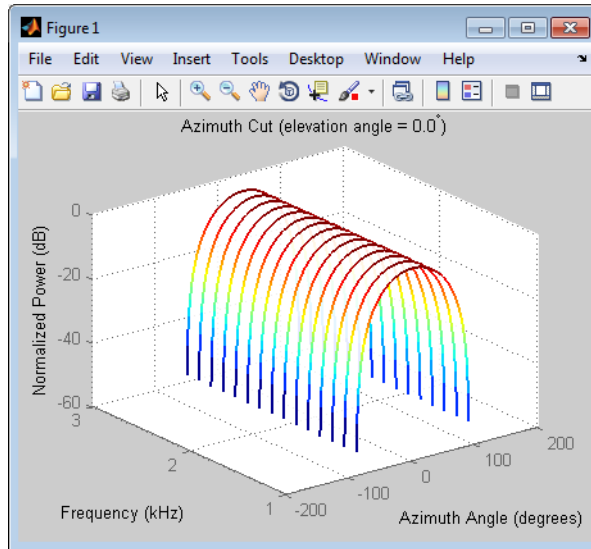

The plot shows that the element pattern is constant over the entire bandwidth.

Plot the response pattern of the 11-element array over the same series of frequencies.

```
figure;
plotResponse(ha,plotFreq,c,'OverlayFreq',false);
```

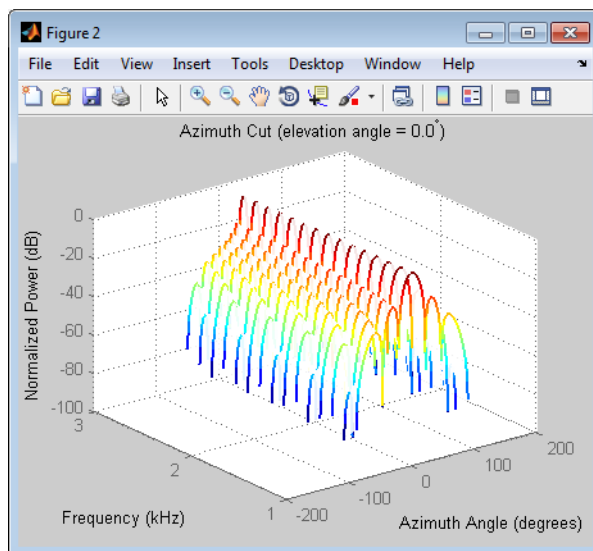



Apply a subband phase shift beamformer to the array. The direction of interest is 30 degrees azimuth and 0 degrees elevation.

```
direction = [30;0];
numbands = 8;
hbf = phased.SubbandPhaseShiftBeamformer('SensorArray',ha,...
    'Direction',direction,...
    'OperatingFrequency',fc,'PropagationSpeed',c,...
    'SampleRate',1e3,...
    'WeightsOutputPort',true,'SubbandsOutputPort',true,...
    'NumSubbands',numbands);
rx = ones(numbands,numels);
[y,w,centerFreq] = step(hbf,rx);
```

Plot the response pattern of the array again, using the weights and center frequencies from the beamformer.

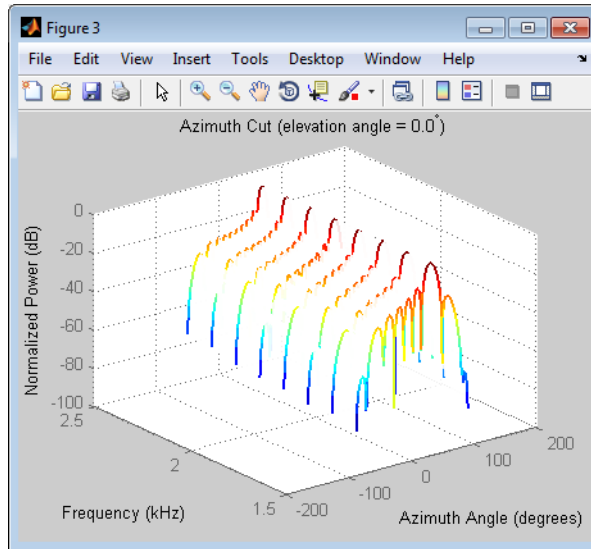
```
figure;
plotResponse(ha,centerFreq',c,'Weights',w,'OverlayFreq',false);
```



The plot shows the beamformed pattern at the center frequency of each subband.

Plot the response pattern at selected frequencies using a two-dimensional format.

```
centerFreq = fftshift(centerFreq);
w = fftshift(w,2);
idx = [1 5 8];
figure;
plotResponse(ha,centerFreq(idx)',c,'Weights',w(:,idx));
legend('Location','South')
```

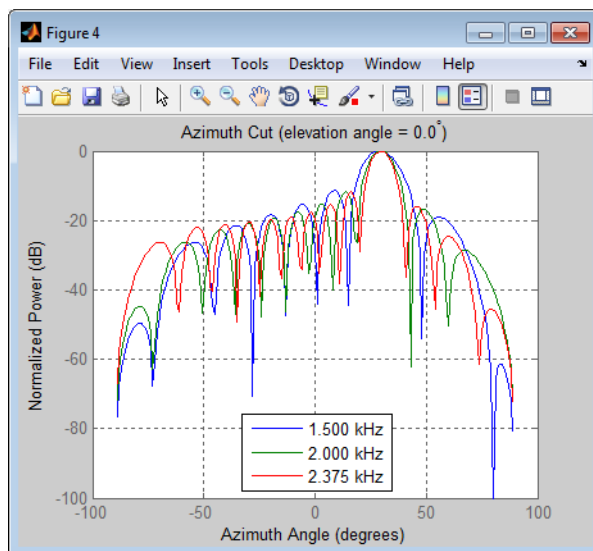

This plot shows that the main beam direction remains constant, but the beam width decreases with frequency.

Direction-of-Arrival (DOA) Estimation

- “Beamscan Direction-of-Arrival Estimation” on page 6-2
- “Super-resolution DOA Estimation” on page 6-4

Beamscan Direction-of-Arrival Estimation

This example shows how to use the nonparametric beamscan technique to estimate the direction of arrival (DOA) of signals. The beamscan algorithm estimates the DOAs by scanning the array beam over a region of interest. The algorithm computes the output power for each beam scan angle and identifies the maxima as the DOA estimates.

Construct a ULA consisting of ten elements. Assume the carrier frequency of the incoming narrowband sources is 1 GHz.

```
fc = 1e9;
lambda = physconst('LightSpeed')/fc;
hula = phased.ULA('NumElements',10,'ElementSpacing',lambda/2);
hula.Element.FrequencyRange = [8e8 1.2e9];
```

Assume that there is a wavefield incident on the ULA consisting of two linear FM pulses. The DOAs of the two sources are 30 degrees azimuth and 60 degrees azimuth. Both sources have elevation angles of zero degrees.

```
hwav = phased.LinearFMWaveform('SweepBandwidth',1e5,...
    'PulseWidth',5e-6,'OutputFormat','Pulses','NumPulses',1);
sig1 = step(hwav);
sig2 = sig1;
ang1 = [30; 0];
ang2 = [60;0];
arraysig = collectPlaneWave(hula,[sig1 sig2],[ang1 ang2],fc);
rng default
npower = 0.01;
noise = sqrt(npower/2)*...
    (randn(size(arraysig))+1i*randn(size(arraysig)));
rxsig = arraysig+noise;
```

Implement a beamscan DOA estimator. Output the DOA estimates, and plot the spatial spectrum.

```
hbeam = phased.BeamscanEstimator('SensorArray',hula,...
    'OperatingFrequency',fc,'ScanAngles',-90:90,...
    'DOAOutputPort',true,'NumSignals',2);
[y,sigang] = step(hbeam,rxsig);
plotSpectrum(hbeam);
```

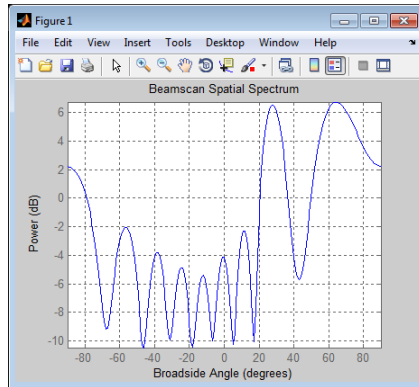

Related Examples

- “Super-resolution DOA Estimation” on page 6-4
- Direction of Arrival Estimation with Beamscan and MVDR

Super-resolution DOA Estimation

This example shows how to estimate angles of arrival from two separate signal sources when both angles fall within the main lobe of the array response. In this example, a beamscan DOA estimator cannot resolve the two sources. However, a super-resolution DOA estimator that uses the root MUSIC algorithm can do so.

Plot the array response of the ULA used in the “Beamscan Direction-of-Arrival Estimation” on page 6-2 example. Zoom in on the main lobe.

```
fc = 1e9;
lambda = physconst('LightSpeed')/fc;
hula = phased.ULA('NumElements',10,'ElementSpacing',lambda/2);
hula.Element.FrequencyRange = [8e8 1.2e9];
plotResponse(hula,fc,physconst('LightSpeed'));
axis([-25 25 -30 0]);
```

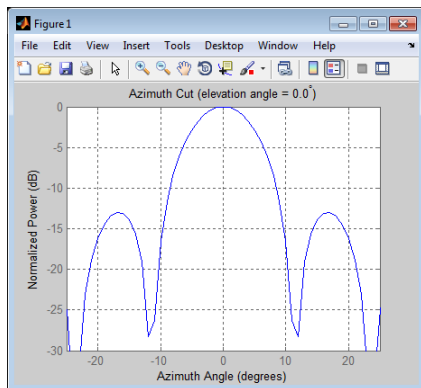

Receive two signal sources with DOAs separated by ten degrees.

```
ang1 = [30; 0];
ang2 = [40; 0];
Nsnapshots = 1000;
rng default
npower = 0.01;
rxsig = sensorsig(getElementPosition(hula)/lambda,...
    Nsnapshots,[ang1 ang2],npower);
```

Estimate the directions of arrival using the beamscan estimator. Because both DOAs fall inside the main lobe of the array response, the beamscan DOA estimator cannot resolve them as separate sources.

```
hbeam = phased.BeamscanEstimator('SensorArray',hula,...
    'OperatingFrequency',fc,'ScanAngles',-90:90,...
    'DOAOutputPort',true,'NumSignals',2);
[~,sigang] = step(hbeam,rxsig);
figure;
plotSpectrum(hbeam);
```

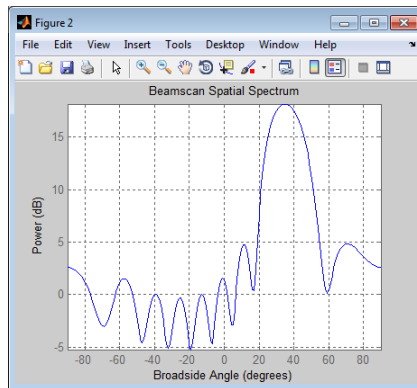

Use a super-resolution DOA estimator, `phased.RootMUSICEstimator` to estimate the two directions. This estimator offers better resolution than the nonparametric beamscan estimator.

```
hroot = phased.RootMUSICEstimator('SensorArray',hula,...
    'OperatingFrequency',fc,'NumSignalsSource','Property',...
    'NumSignals',2,'ForwardBackwardAveraging',true);
doa_est = step(hroot,rxsig)
```

```
doa_est =
    40.0091    30.0048
```

This estimator correctly identifies the two distinct directions of arrival.

See Also `phased.RootMUSICEstimator` |

Related Examples

- “Beamscan Direction-of-Arrival Estimation” on page 6-2
- High Resolution Direction of Arrival Estimation

Space-Time Adaptive Processing (STAP)

- “Angle-Doppler Response” on page 7-2
- “Displaced Phase Center Antenna (DPCA) Pulse Canceller” on page 7-9
- “Adaptive Displaced Phase Center Antenna Pulse Canceller” on page 7-14
- “Sample Matrix Inversion (SMI) Beamformer” on page 7-21

Angle-Doppler Response

In this section...

“Benefits of Visualizing Angle-Doppler Response” on page 7-2

“Angle-Doppler Response of a Stationary Target at a Stationary Array” on page 7-2

“Angle-Doppler Response of a Stationary Target Return at a Moving Array” on page 7-5

Benefits of Visualizing Angle-Doppler Response

Visualizing a signal in the angle-Doppler domain can help you identify characteristics of the signal in direction and speed. You can distinguish among targets moving at various speeds in various directions. If a transmitter platform is stationary, returns from stationary targets map to zero in the Doppler domain while returns from moving targets exhibit a nonzero Doppler shift. If you visualize the array response in the angle-Doppler domain, a stationary target produces a response at a specified angle and zero Doppler.

You can use the `phased.AngleDopplerResponse` object to visualize the angle-Doppler response of input data. The `phased.AngleDopplerResponse` object uses a conventional narrowband (phase shift) beamformer and an FFT-based Doppler filter to compute the angle-Doppler response.

Angle-Doppler Response of a Stationary Target at a Stationary Array

The array is a six-element uniform linear array (ULA) located at the global origin $[0;0;0]$. The target is located at $[5000; 5000; 0]$ and has a nonfluctuating radar cross section (RCS) of 1 square meter. Both the array and target are stationary.

The array operates at 4 GHz with elements spaced at one-half the operating wavelength. The array transmits a rectangular pulse 2 microseconds in duration with a pulse repetition frequency (PRF) of 5 kHz.

Construct the objects needed to simulate the target response at the array.

```

hant = phased.IsotropicAntennaElement...
    ('FrequencyRange',[8e8 5e9],'BackBaffled',true);
lambda = physconst('LightSpeed')/4e9;
hula = phased.ULA(6,'Element',hant,'ElementSpacing',lambda/2);
hwav = phased.RectangularWaveform('PulseWidth',2e-006,...
    'PRF',5e3,'SampleRate',1e6,'NumPulses',1);
hrad = phased.Radiator('Sensor',hula,...
    'PropagationSpeed',physconst('LightSpeed'),...
    'OperatingFrequency',4e9);
hcol = phased.Collector('Sensor',hula,...
    'PropagationSpeed',physconst('LightSpeed'),...
    'OperatingFrequency',4e9);
htxplat = phased.Platform('InitialPosition',[0;0;0],...
    'Velocity',[0;0;0]);
htgt = phased.RadarTarget('MeanRCS',1,'Model','nonfluctuating');
htgtplat = phased.Platform('InitialPosition',[5e3; 5e3; 0],...
    'Velocity',[0;0;0]);
hspace = phased.FreeSpace('OperatingFrequency',4e9,...
    'TwoWayPropagation',false,'SampleRate',1e6);
hrx = phased.ReceiverPreamp('NoiseFigure',0,...
    'EnableInputPort',true,'SampleRate',1e6,'Gain',40);
htx = phased.Transmitter('PeakPower',1e4,...
    'InUseOutputPort',true,'Gain',40);

```

Propagate ten rectangular pulses to and from the target, and collect the responses at the array.

```

PRF = 5e3;
NumPulses = 10;
wav = step(hwav);
tgtloc = htgtplat.InitialPosition;
txloc = htxplat.InitialPosition;
M = hwav.SampleRate*1/PRF;
N = hula.NumElements;
rxsig = zeros(M,N,NumPulses);

for n = 1:NumPulses
    % get angle to target
    [~,tgtang] = rangeangle(tgtloc,txloc);
    % transmit pulse

```

```

[txsig,txstatus] = step(htx,wav);
% radiate pulse
txsig = step(hrad,txsig,tgtang);
% propagate pulse to target
txsig = step(hspace,txsig,txloc,tgtloc,[0;0;0],[0;0;0]);
% reflect pulse off stationary target
txsig = step(htgt,txsig);
% propagate pulse to array
txsig = step(hspace,txsig,tgtloc,txloc,[0;0;0],[0;0;0]);
% collect pulse
rxsig(:,:,n) = step(hcol,txsig,tgtang);
% receive pulse
rxsig(:,:,n) = step(hrx,rxsig(:,:,n),~txstatus);
end

```

Determine and plot the angle-Doppler response. Place the string +Target at the expected azimuth angle and Doppler frequency.

```

tgtdoppler = 0;
tgtLocation = global2localcoord(tgtloc,'rs',txloc);
tgtazang = tgtLocation(1);
tgtelang = tgtLocation(2);
tgtrng = tgtLocation(3);
tgtcell = val2ind(tgtrng,...
    physconst('LightSpeed')/(2*hwav.SampleRate));
snapshot = shiftdim(rxsig(tgtcell,:,:)); % Remove singleton dim
hadresp = phased.AngleDopplerResponse('SensorArray',hula,...
    'OperatingFrequency',4e9, ...
    'PropagationSpeed',physconst('LightSpeed'),...
    'PRF',PRF, 'ElevationAngle',tgtelang);
plotResponse(hadresp,snapshot);
text(tgtazang,tgtdoppler,'+Target');

```

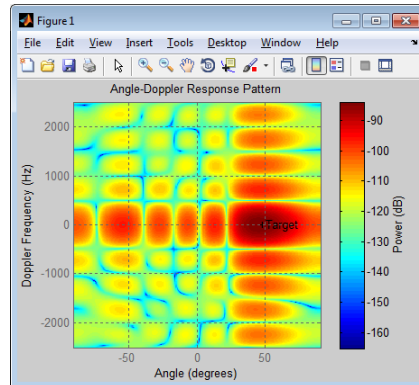

As expected, the angle-Doppler response shows the greatest response at zero Doppler and 45 degrees azimuth.

Angle-Doppler Response of a Stationary Target Return at a Moving Array

This example illustrates the nonzero Doppler shift exhibited by a stationary target in the presence of array motion. In general, this nonzero shift complicates the detection of slow-moving targets because the motion-induced Doppler shift and spread of the clutter returns obscure the Doppler shifts of such targets.

The scenario in this example is identical to that of “Angle-Doppler Response of a Stationary Target at a Stationary Array” on page 7-2, except that the ULA is moving at a constant velocity. For convenience, the MATLAB® code to set up the objects is repeated. Notice that the `InitialPosition` and `Velocity` properties of the `htxplat` object have changed. The `InitialPosition` property value is set to simulate an airborne ULA. The motivation for selecting the particular value of the `Velocity` property is explained in “Applicability of DPCA Pulse Canceller” on page 7-9.

```
hant = phased.IsotropicAntennaElement...
    ('FrequencyRange',[8e8 5e9],'BackBaffled',true);
lambda = physconst('LightSpeed')/4e9;
hula = phased.ULA(6,'Element',hant,'ElementSpacing',lambda/2);
hwav = phased.RectangularWaveform('PulseWidth',2e-006,...
    'PRF',5e3,'SampleRate',1e6,'NumPulses',1);
```

```

hrad = phased.Radiator('Sensor',hula,...
    'PropagationSpeed',physconst('LightSpeed'),...
    'OperatingFrequency',4e9);
hcol = phased.Collector('Sensor',hula,...
    'PropagationSpeed',physconst('LightSpeed'),...
    'OperatingFrequency',4e9);
vy = (hula.ElementSpacing*hwav.PRF)/2;
htxplat = phased.Platform('InitialPosition',[0;0;3e3],...
    'Velocity',[0;vy;0]);
htgt = phased.RadarTarget('MeanRCS',1,'Model','nonfluctuating');
tgtvel = [0;0;0];
htgtplat = phased.Platform('InitialPosition',[5e3; 5e3; 0],...
    'Velocity',tgtvel);
hspace = phased.FreeSpace('OperatingFrequency',4e9,...
    'TwoWayPropagation',false,'SampleRate',1e6);
hrx = phased.ReceiverPreamp('NoiseFigure',0,...
    'EnableInputPort',true,'SampleRate',1e6,'Gain',40);
htx = phased.Transmitter('PeakPower',1e4,...
    'InUseOutputPort',true,'Gain',40);

```

Transmit ten rectangular pulses toward the target as the ULA is moving. Then, collect the received echoes.

```

PRF = 5e3;
NumPulses = 10;
wav = step(hwav);
tgtloc = htgtplat.InitialPosition;
M = hwav.SampleRate*1/PRF;
N = hula.NumElements;
rxsig = zeros(M,N,NumPulses);
fasttime = unigrid(0,1/hwav.SampleRate,1/PRF,['']);
rangebins = (physconst('LightSpeed')*fasttime)/2;

for n = 1:NumPulses
    % move transmitter
    [txloc,txvel] = step(htxplat,1/PRF);
    % get angle to target
    [~,tgtang] = rangeangle(tgtloc,txloc);
    % transmit pulse
    [txsig,txstatus] = step(htx,wav);

```



```

% radiate pulse
txsig = step(hrad,txsig,tgtang);
% propagate pulse to target
txsig = step(hspace,txsig,txloc,tgtloc,txvel,tgtvel);
% reflect pulse off stationary target
txsig = step(htgt,txsig);
% propagate pulse to array
txsig = step(hspace,txsig,tgtloc,txloc,tgtvel,txvel);
% collect pulse
rxsig(:, :, n) = step(hcol,txsig,tgtang);
% receive pulse
rxsig(:, :, n) = step(hrx,rxsig(:, :, n),~txstatus);
end

```

Calculate the target angles and range with respect to the ULA. Then, calculate the Doppler shift induced by the motion of the phased array.

```

sp = radialspeed(tgtloc,tgtvel,txloc,txvel);
tgtdoppler = 2*speed2dop(sp,lambda);
tgtLocation = global2localcoord(tgtloc,'rs',txloc);
tgtazang = tgtLocation(1);
tgtelang = tgtLocation(2);
tgtrng = tgtLocation(3);

```

The two-way Doppler shift is approximately 1626 Hz. The azimuth angle is 45 degrees and is identical to the stationary ULA example.

Plot the angle-Doppler response.

```

tgtcell = val2ind(tgtrng,...
    physconst('LightSpeed')/(2*hwav.SampleRate));
snapshot = shiftdim(rxsig(tgtcell,:,:)); % Remove singleton dim
hadresp = phased.AngleDopplerResponse('SensorArray',hula,...
    'OperatingFrequency',4e9, ...
    'PropagationSpeed',physconst('LightSpeed'),...
    'PRF',PRF, 'ElevationAngle',tgtelang);
plotResponse(hadresp,snapshot);
text(tgtazang,tgtdoppler,'+Target');

```

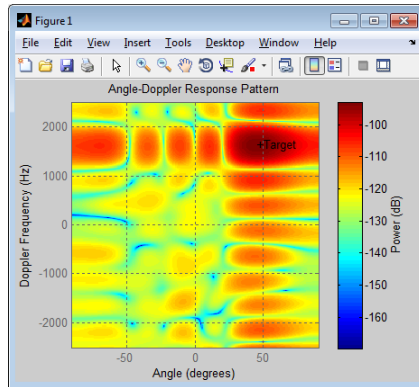

The angle-Doppler response shows the greatest response at 45 degrees azimuth and the expected Doppler shift.

Displaced Phase Center Antenna (DPCA) Pulse Canceller

In this section...

“When to Use the DPCA Pulse Canceller” on page 7-9

“Example: DPCA Pulse Canceller for Clutter Rejection” on page 7-9

When to Use the DPCA Pulse Canceller

In a *moving target indication* (MTI) radar, clutter returns can make it more difficult to detect and track the targets of interest. A rudimentary way to mitigate the effects of clutter returns in such a system is to implement a displaced phase center antenna (DPCA) pulse canceller on the slow-time data.

You can implement a DPCA pulse canceller with `phased.DPCACanceller`. This implementation assumes that the entire array is used on transmit. On receive, the array is divided into two subarrays. The phase centers of the subarrays are separated by twice the distance the platform moves in one pulse repetition interval.

Applicability of DPCA Pulse Canceller

The DPCA pulse canceller is applicable when both these conditions are true:

- Clutter is stationary across pulses.
- The motion satisfies

$$vT = d / 2 \tag{7-1}$$

where:

- v indicates the speed of the platform
- T represents the pulse repetition interval
- d indicates the inter-element spacing of the array

Example: DPCA Pulse Canceller for Clutter Rejection

This example implements a DPCA pulse canceller for clutter rejection.

Assume you have an airborne radar platform modeled by a six-element ULA

operating at 4 GHz. The array elements are spaced at one-half the wavelength of the 4 GHz carrier frequency. The radar emits ten rectangular pulses two microseconds in duration with a PRF of 5 kHz. The platform moves along the array axis with a speed equal to one-half the product of the element spacing and the PRF. As a result, the condition in Equation 7-1 applies. The target has a nonfluctuating RCS of 1 square meter and moves with a constant velocity vector of $[15; 15; 0]$. The following MATLAB code constructs the required System objects to simulate the signal received by the ULA.

```
PRF = 5e3;
fc = 4e9; fs = 1e6;
c = physconst('LightSpeed');
hant = phased.IsotropicAntennaElement...
    ('FrequencyRange',[8e8 5e9], 'BackBaffled', true);
lambda = c/fc;
hula = phased.ULA(6, 'Element', hant, 'ElementSpacing', lambda/2);
hwav = phased.RectangularWaveform('PulseWidth', 2e-6, ...
    'PRF', PRF, 'SampleRate', fs, 'NumPulses', 1);
hrad = phased.Radiator('Sensor', hula, ...
    'PropagationSpeed', c, ...
    'OperatingFrequency', fc);
hcol = phased.Collector('Sensor', hula, ...
    'PropagationSpeed', c, ...
    'OperatingFrequency', fc);
vy = (hula.ElementSpacing * PRF)/2;
htxplat = phased.Platform('InitialPosition', [0;0;3e3], ...
    'Velocity', [0;vy;0]);
hclutter = phased.ConstantGammaClutter('Sensor', hula, ...
    'PropagationSpeed', hrad.PropagationSpeed, ...
    'OperatingFrequency', hrad.OperatingFrequency, ...
    'SampleRate', fs, ...
    'TransmitSignalInputPort', true, ...
    'PRF', PRF, ...
    'Gamma', surfacegamma('woods', hrad.OperatingFrequency), ...
    'EarthModel', 'Flat', ...
    'BroadsideDepressionAngle', 0, ...
    'MaximumRange', hrad.PropagationSpeed/(2*PRF), ...
    'PlatformHeight', htxplat.InitialPosition(3), ...
    'PlatformSpeed', norm(htxplat.Velocity), ...
    'PlatformDirection', [90;0]);
```

```

htgt = phased.RadarTarget('MeanRCS',1,...
    'Model','Nonfluctuating','OperatingFrequency',fc);
htgtplat = phased.Platform('InitialPosition',[5e3; 5e3; 0],...
    'Velocity',[15;15;0]);
hspace = phased.FreeSpace('OperatingFrequency',fc,...
    'TwoWayPropagation',false,'SampleRate',fs);
hrx = phased.ReceiverPreamp('NoiseFigure',0,...
    'EnableInputPort',true,'SampleRate',fs,'Gain',40);
htx = phased.Transmitter('PeakPower',1e4,...
    'InUseOutputPort',true,'Gain',40);

```

Propagate the ten rectangular pulses to and from the target, and collect the responses at the array. Also, compute clutter echoes using the constant gamma model with a gamma value corresponding to wooded terrain.

```

NumPulses = 10;
wav = step(hwav);
M = fs/PRF;
N = hula.NumElements;
rxsig = zeros(M,N,NumPulses);
csig = zeros(M,N,NumPulses);
fasttime = unigrid(0,1/fs,1/PRF, '[]');
rangebins = (c * fasttime)/2;
hclutter.SeedSource = 'Property';
hclutter.Seed = 5;

for n = 1:NumPulses
    [txloc,txvel] = step(htxplat,1/PRF); % move transmitter
    [tgtloc,tgtvel] = step(htgtplat,1/PRF); % move target
    [~,tgtang] = rangeangle(tgtloc,txloc); % get angle to target
    [txsig1,txstatus] = step(htx,wav); % transmit pulse
    csig(:, :, n) = step(hclutter,txsig1(abs(txsig1)>0)); % collect clutter
    txsig = step(hrad,txsig1,tgtang); % radiate pulse
    txsig = step(hspace,txsig,txloc,tgtloc,...
        txvel,tgtvel); % propagate to target
    txsig = step(htgt,txsig); % reflect off target
    txsig = step(hspace,txsig,tgtloc,txloc,...
        tgtvel,txvel); % propagate to array
    rxsig(:, :, n) = step(hcol,txsig,tgtang); % collect pulse
    rxsig(:, :, n) = step(hrx,rxsig(:, :, n) + csig(:, :, n),...

```

```
-txstatus); % receive pulse plus clutter return
end
```

Determine the target's range, range gate, and two-way Doppler shift.

```
sp = radialspeed(tgtloc,tgtvel,txloc,txvel);
tgtdoppler = 2*speed2dop(sp,lambda);
tgtLocation = global2localcoord(tgtloc,'rs',txloc);
tgtazang = tgtLocation(1);
tgtelang = tgtLocation(2);
tgtrng = tgtLocation(3);
tgtcell = val2ind(tgtrng,c/(2 * fs));
```

Use noncoherent pulse integration to visualize the signal received by the ULA for the first of the ten pulses. Mark the target's range gate with a vertical dashed line.

```
firstpulse = pulsint(rxsig(:, :, 1), 'noncoherent');
figure;
plot([tgtrng tgtrng],[0 0.1], '-.', 'rangebins', firstpulse);
title('Noncoherent Integration of 1st Pulse at the ULA');
xlabel('Range (m)'); ylabel('Magnitude');
```

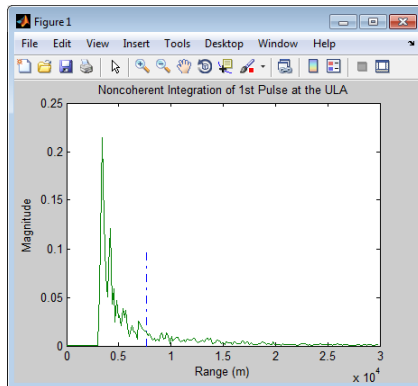

The large-magnitude clutter returns obscure the presence of the target. Apply the DPCA pulse canceller to reject the clutter.

```
hstap = phased.DPCACanceller('SensorArray', hu1a, 'PRF', PRF, ...
    'PropagationSpeed', c, ...
```

```

    'OperatingFrequency',fc,...
    'Direction',[0;0],'Doppler',tgtdoppler,...
    'WeightsOutputPort',true);
[y,w] = step(hstap,rxsig,tgtcell);

```

Plot the result of applying the DPCA pulse canceller. Mark the target range gate with a vertical dashed line.

```

figure;
plot([tgtrng,tgtrng],[0 3.5e-5], '-.', rangebins,abs(y));
title('DPCA Canceller Output');
xlabel('Range (m)'), ylabel('Magnitude');

```

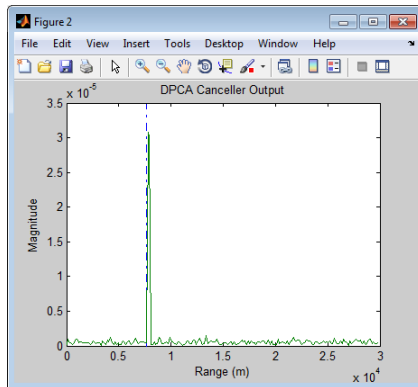

The DPCA pulse canceller has significantly rejected the clutter. As a result, the target is visible at the expected range gate.

Adaptive Displaced Phase Center Antenna Pulse Canceller

In this section...

“When to Use the Adaptive DPCA Pulse Canceller” on page 7-14

“Example: Adaptive DPCA Pulse Canceller” on page 7-14

When to Use the Adaptive DPCA Pulse Canceller

Consider an airborne radar system that needs to suppress clutter returns and possibly jammer interference. Under any of the following conditions, you might choose an adaptive DPCA (ADPCA) pulse canceller for suppressing these effects.

- Jamming and other interference effects are substantial. The DPCA pulse canceller is susceptible to interference because the DPCA pulse canceller does not use the received data.
- The sample matrix inversion (SMI) algorithm is inapplicable because of computational expense or a rapidly changing environment.

The `phased.ADPCAPulseCanceller` object implements an ADPCA pulse canceller. This pulse canceller uses the data received from two consecutive pulses to estimate the space-time interference covariance matrix. In particular, the object lets you specify:

- The number of training cells. The algorithm uses training cells to estimate the interference. In general, a larger number of training cells leads to a better estimate of interference.
- The number of guard cells close to the target cells. The algorithm recognizes guard cells to prevent target returns from contaminating the estimate of the interference.

Example: Adaptive DPCA Pulse Canceller

This example implements an adaptive DPCA pulse canceller for clutter and interference rejection. The scenario is identical to the one in “Example: DPCA Pulse Canceller for Clutter Rejection” on page 7-9 except that a stationary broadband barrage jammer is added at $[3.5e3; 1e3; 0]$. The jammer has an effective radiated power of 1 kw.

To repeat the scenario for convenience, the airborne radar platform is a six-element ULA operating at 4 GHz. The array elements are spaced at one-half the wavelength of the 4 GHz carrier frequency. The radar emits ten rectangular pulses two μs in duration with a PRF of 5 kHz. The platform is moving along the array axis with a speed equal to one-half the product of the element spacing and the PRF. As a result, the condition in Equation 7-1 applies. The target has a nonfluctuating RCS of 1 square meter and is moving with a constant velocity vector of [15;15;0].

The following commands construct the required System objects to simulate the scenario.

```
PRF = 5e3;
fc = 4e9; fs = 1e6;
c = physconst('LightSpeed');
hant = phased.IsotropicAntennaElement...
    ('FrequencyRange',[8e8 5e9], 'BackBaffled', true);
lambda = c/fc;
hula = phased.ULA(6, 'Element', hant, 'ElementSpacing', lambda/2);
hwav = phased.RectangularWaveform('PulseWidth', 2e-6, ...
    'PRF', PRF, 'SampleRate', fs, 'NumPulses', 1);
hrad = phased.Radiator('Sensor', hula, ...
    'PropagationSpeed', c, ...
    'OperatingFrequency', fc);
hcol = phased.Collector('Sensor', hula, ...
    'PropagationSpeed', c, ...
    'OperatingFrequency', fc);
vy = (hula.ElementSpacing * PRF)/2;
htxplat = phased.Platform('InitialPosition', [0;0;3e3], ...
    'Velocity', [0;vy;0]);
hclutter = phased.ConstantGammaClutter('Sensor', hula, ...
    'PropagationSpeed', hrad.PropagationSpeed, ...
    'OperatingFrequency', hrad.OperatingFrequency, ...
    'SampleRate', fs, ...
    'TransmitSignalInputPort', true, ...
    'PRF', PRF, ...
    'Gamma', surfacegamma('woods', hrad.OperatingFrequency), ...
    'EarthModel', 'Flat', ...
    'BroadsideDepressionAngle', 0, ...
    'MaximumRange', hrad.PropagationSpeed/(2*PRF), ...
```

```

        'PlatformHeight',htxplat.InitialPosition(3),...
        'PlatformSpeed',norm(htxplat.Velocity),...
        'PlatformDirection',[90;0]);
htgt = phased.RadarTarget('MeanRCS',1,...
    'Model','Nonfluctuating','OperatingFrequency',fc);
htgplat = phased.Platform('InitialPosition',[5e3; 5e3; 0],...
    'Velocity',[15;15;0]);
hjammer = phased.BarrageJammer('ERP',1e3,'SamplesPerFrame',200);
hjammerplat = phased.Platform(...
    'InitialPosition',[3.5e3; 1e3; 0],'Velocity',[0;0;0]);
hspace = phased.FreeSpace('OperatingFrequency',fc,...
    'TwoWayPropagation',false,'SampleRate',fs);
hrx = phased.ReceiverPreamp('NoiseFigure',0,...
    'EnableInputPort',true,'SampleRate',fs,'Gain',40);
htx = phased.Transmitter('PeakPower',1e4,...
    'InUseOutputPort',true,'Gain',40);

```

Propagate the ten rectangular pulses to and from the target and collect the responses at the array. Compute clutter echoes using the constant gamma model with a gamma value corresponding to wooded terrain. Also, propagate the jamming signal from the jammer location to the airborne ULA.

```

NumPulses = 10;
wav = step(hwav);
M = fs/PRF;
N = hula.NumElements;
rxsig = zeros(M,N,NumPulses);
csig = zeros(M,N,NumPulses);
jsig = zeros(M,N,NumPulses);
fasttime = unigrid(0,1/fs,1/PRF, '[]');
rangebins = (c * fasttime)/2;
hclutter.SeedSource = 'Property';
hclutter.Seed = 40543;
hjammer.SeedSource = 'Property';
hjammer.Seed = 96703;
hrx.SeedSource = 'Property';
hrx.Seed = 56113;
jamloc = hjammerplat.InitialPosition;

for n = 1:NumPulses

```

```

[txloc,txvel] = step(htxplat,1/PRF); % move transmitter
[tgtloc,tgtvel] = step(htgtplat,1/PRF); % move target
[~,tgtang] = rangeangle(tgtloc,txloc); % get angle to target
[txsig,txstatus] = step(htx,wav); % transmit pulse
csig(:, :, n) = step(hclutter,txsig(abs(txsig)>0)); % collect clutter

txsig = step(hrad,txsig,tgtang); % radiate pulse
txsig = step(hspace,txsig,txloc,tgtloc,...
    txvel,tgtvel); % propagate pulse to target
txsig = step(htgt,txsig); % reflect off target
txsig = step(hspace,txsig,tgtloc,txloc,...
    tgtvel,txvel); % propagate to array
rxsig(:, :, n) = step(hcol,txsig,tgtang); % collect pulse

jamsig = step(hjammer); % generate jammer signal
[~,jamang] = rangeangle(jamloc,txloc); % angle from jammer to transmitter
jamsig = step(hspace,jamsig,jamloc,txloc,...
    [0;0;0],txvel); % propagate jammer signal
jsig(:, :, n) = step(hcol,jamsig,jamang); % collect jammer signal

rxsig(:, :, n) = step(hrx,...
    rxsig(:, :, n) + csig(:, :, n) + jsig(:, :, n),...
    ~txstatus); % receive pulse plus clutter return plus jammer signal
end

```

Determine the target's range, range gate, and two-way Doppler shift.

```

sp = radialspeed(tgtloc, htgtplat.Velocity, ...
    txloc, htxplat.Velocity);
tgtdoppler = 2*speed2dop(sp,lambda);
tgtLocation = global2localcoord(tgtloc,'rs',txloc);
tgtazang = tgtLocation(1);
tgtelang = tgtLocation(2);
tgtrng = tgtLocation(3);
tgtcell = val2ind(tgtrng,c/(2 * fs));

```

Process the array responses using the nonadaptive DPCA pulse canceller. To do so, construct the DPCA object, and apply it to the received signals.

```

hstap = phased.DPCACanceller('SensorArray',hula,'PRF',PRF,...
    'PropagationSpeed',c,...

```

```

    'OperatingFrequency',fc,...
    'Direction',[0;0],'Doppler',tgtdoppler,...
    'WeightsOutputPort',true);
[y,w] = step(hstap,rxsig,tgtcell);

```

Plot the DPCA result with the target range marked by a vertical dashed line. Notice how the presence of the interference signal has obscured the target.

```

figure;
plot([tgtrng,tgtrng],[0 7e-2],'-.',rangebins,abs(y));
axis tight;
xlabel('Range (m)'), ylabel('Magnitude');
title('DPCA Canceller Output with Jamming')

```

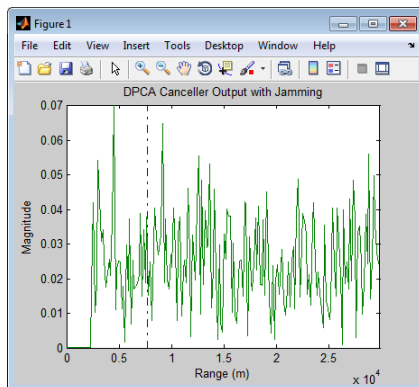

Apply the adaptive DPCA pulse canceller. Use 100 training cells and 4 guard cells, two on each side of the target range gate.

```

hstap = phased.ADPCACanceller('SensorArray',hula,'PRF',PRF,...
    'PropagationSpeed',c,...
    'OperatingFrequency',fc,...
    'Direction',[0;0],'Doppler',tgtdoppler,...
    'WeightsOutputPort',true,'NumGuardCells',4,...
    'NumTrainingCells',100);
[y_adpca,w_adpca] = step(hstap,rxsig,tgtcell);

```

Plot the result with the target range marked by a vertical dashed line. Notice how the adaptive DPCA pulse canceller enables you to detect the target in the presence of the jamming signal.

```

figure;
plot([tgtrng,tgtrng],[0 4e-7],'-.',rangebins,abs(y_adpca));
axis tight;
title('ADPCA Cancellor Output with Jamming');
xlabel('Range (m)'), ylabel('Magnitude');

```

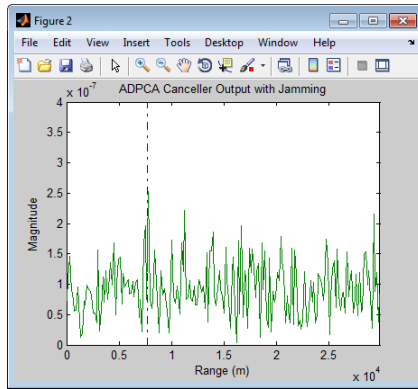

Examine the angle-Doppler response. Notice the presence of the clutter ridge in the angle-Doppler plane and the null at the jammer's broadside angle for all Doppler frequencies.

```

hadresp = phased.AngleDopplerResponse('SensorArray',hula,...
    'OperatingFrequency',fc,...
    'PropagationSpeed',c,...
    'PRF',PRF,'ElevationAngle',tgtelang);
figure;
plotResponse(hadresp,w_adpca);
title('Angle-Doppler Response with ADPCA Pulse Cancellation');
text(az2broadside(jamang(1),jamang(2)) + 10,...
    0,'\leftarrow Interference Null')

```

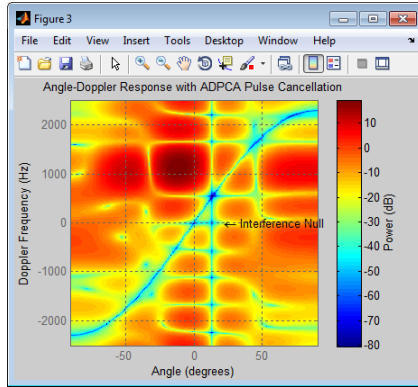

Sample Matrix Inversion (SMI) Beamformer

In this section...
“When to Use the SMI Beamformer” on page 7-21
“Example: Sample Matrix Inversion (SMI) Beamformer” on page 7-21

When to Use the SMI Beamformer

In situations where an airborne radar system needs to suppress clutter returns and jammer interference, the system needs a more sophisticated algorithm than a DPCA pulse canceller can provide. One option is the sample matrix inversion (SMI) algorithm. SMI is the optimum STAP algorithm and is often used as a baseline for comparison with other algorithms.

The SMI algorithm is computationally expensive and assumes a stationary environment across many pulses. If you need to suppress clutter returns and jammer interference with less computation, or in a rapidly changing environment, consider using an ADPCA pulse canceller instead.

The phased.STAPSMIBeamformer object implements the SMI algorithm. In particular, the object lets you specify:

- The number of training cells. The algorithm uses training cells to estimate the interference. In general, a larger number of training cells leads to a better estimate of interference.
- The number of guard cells close to the target cells. The algorithm recognizes guard cells to prevent target returns from contaminating the estimate of the interference.

Example: Sample Matrix Inversion (SMI) Beamformer

This scenario is identical to the one presented in “Example: Adaptive DPCA Pulse Canceller” on page 7-14. You can run the code for both examples to compare the ADPCA pulse canceller with the SMI beamformer. The example details and code are repeated for convenience.

To repeat the scenario for convenience, the airborne radar platform is a six-element ULA operating at 4 GHz. The array elements are spaced at

one-half the wavelength of the 4 GHz carrier frequency. The radar emits ten rectangular pulses two μs in duration with a PRF of 5 kHz. The platform is moving along the array axis with a speed equal to one-half the product of the element spacing and the PRF. The target has a nonfluctuating RCS of 1 square meter and is moving with a constant velocity vector of $[15; 15; 0]$. A stationary broadband barrage jammer is located at $[3.5\text{e}3; 1\text{e}3; 0]$. The jammer has an effective radiated power of 1 kw.

The following commands construct the required System objects to simulate the scenario.

```
PRF = 5e3;
fc = 4e9; fs = 1e6;
c = physconst('LightSpeed');
hant = phased.IsotropicAntennaElement...
    ('FrequencyRange',[8e8 5e9], 'BackBaffled', true);
lambda = c/fc;
hula = phased.ULA(6, 'Element', hant, 'ElementSpacing', lambda/2);
hwav = phased.RectangularWaveform('PulseWidth', 2e-6, ...
    'PRF', PRF, 'SampleRate', fs, 'NumPulses', 1);
hrad = phased.Radiator('Sensor', hula, ...
    'PropagationSpeed', c, ...
    'OperatingFrequency', fc);
hcol = phased.Collector('Sensor', hula, ...
    'PropagationSpeed', c, ...
    'OperatingFrequency', fc);
vy = (hula.ElementSpacing * PRF)/2;
htxplat = phased.Platform('InitialPosition', [0;0;3e3], ...
    'Velocity', [0;vy;0]);
hclutter = phased.ConstantGammaClutter('Sensor', hula, ...
    'PropagationSpeed', hrad.PropagationSpeed, ...
    'OperatingFrequency', hrad.OperatingFrequency, ...
    'SampleRate', fs, ...
    'TransmitSignalInputPort', true, ...
    'PRF', PRF, ...
    'Gamma', surfacegamma('woods', hrad.OperatingFrequency), ...
    'EarthModel', 'Flat', ...
    'BroadsideDepressionAngle', 0, ...
    'MaximumRange', hrad.PropagationSpeed/(2*PRF), ...
    'PlatformHeight', htxplat.InitialPosition(3), ...
```



```

        'PlatformSpeed',norm(htxplat.Velocity),...
        'PlatformDirection',[90;0]);
htgt = phased.RadarTarget('MeanRCS',1,...
    'Model','Nonfluctuating','OperatingFrequency',fc);
htgtplat = phased.Platform('InitialPosition',[5e3; 5e3; 0],...
    'Velocity',[15;15;0]);
hjammer = phased.BarrageJammer('ERP',1e3,'SamplesPerFrame',200);
hjammerplat = phased.Platform(...
    'InitialPosition',[3.5e3; 1e3; 0],'Velocity',[0;0;0]);
hspace = phased.FreeSpace('OperatingFrequency',fc,...
    'TwoWayPropagation',false,'SampleRate',fs);
hrx = phased.ReceiverPreamp('NoiseFigure',0,...
    'EnableInputPort',true,'SampleRate',fs,'Gain',40);
htx = phased.Transmitter('PeakPower',1e4,...
    'InUseOutputPort',true,'Gain',40);

```

Propagate the ten rectangular pulses to and from the target and collect the responses at the array. Compute clutter echoes using the constant gamma model with a gamma value corresponding to wooded terrain. Also, propagate the jamming signal from the jammer location to the airborne ULA.

```

NumPulses = 10;
wav = step(hwav);
M = fs/PRF;
N = hula.NumElements;
rxsig = zeros(M,N,NumPulses);
csig = zeros(M,N,NumPulses);
jsig = zeros(M,N,NumPulses);
fasttime = unigrid(0,1/fs,1/PRF, '[]');
rangebins = (c * fasttime)/2;
hclutter.SeedSource = 'Property';
hclutter.Seed = 40543;
hjammer.SeedSource = 'Property';
hjammer.Seed = 96703;
hrx.SeedSource = 'Property';
hrx.Seed = 56113;
jamloc = hjammerplat.InitialPosition;

for n = 1:NumPulses
    [txloc,txvel] = step(htxplat,1/PRF); % move transmitter

```

```

[tgtloc,tgtvel] = step(htgtplat,1/PRF); % move target
[-,tgtang] = rangeangle(tgtloc,txloc); % get angle to target
[txsig,txstatus] = step(htx,wav); % transmit pulse
csig(:, :, n) = step(hclutter,txsig(abs(txsig)>0)); % collect clutter

txsig = step(hrad,txsig,tgtang); % radiate pulse
txsig = step(hspace,txsig,txloc,tgtloc,...
    txvel,tgtvel); % propagate pulse to target
txsig = step(htgt,txsig); % reflect off target
txsig = step(hspace,txsig,tgtloc,txloc,...
    tgtvel,txvel); % propagate to array
rxsig(:, :, n) = step(hcol,txsig,tgtang); % collect pulse

jamsig = step(hjammer); % generate jammer signal
[-,jamang] = rangeangle(jamloc,txloc); % angle from jammer to transmitter
jamsig = step(hspace,jamsig,jamloc,txloc,...
    [0;0;0],txvel); % propagate jammer signal
jsig(:, :, n) = step(hcol,jamsig,jamang); % collect jammer signal

rxsig(:, :, n) = step(hrx,...
    rxsig(:, :, n) + csig(:, :, n) + jsig(:, :, n),...
    ~txstatus); % receive pulse plus clutter return plus jammer signal
end

```

Determine the target's range, range gate, and two-way Doppler shift.

```

sp = radialspeed(tgtloc, htgtplat.Velocity, ...
    txloc, httxplat.Velocity);
tgtdoppler = 2*speed2dop(sp,lambda);
tgtLocation = global2localcoord(tgtloc,'rs',txloc);
tgtazang = tgtLocation(1);
tgtelang = tgtLocation(2);
tgtrng = tgtLocation(3);
tgtcell = val2ind(tgtrng,c/(2 * fs));

```

Construct an SMI beamformer object. Use 100 training cells, 50 on each side of the target range gate. Use four guard cells, two range gates in front of the target cell and two range gates beyond the target cell. Obtain the beamformer response and weights.

```

tgtang = [tgtazang; tgtelang];

```

```

hstap = phased.STAPSMIBeamformer('SensorArray',hula,...
    'PRF',PRF,'PropagationSpeed',c,...
    'OperatingFrequency',fc,...
    'Direction',tgtang,'Doppler',tgtdoppler,...
    'WeightsOutputPort',true,...
    'NumGuardCells',4,'NumTrainingCells',100);
[y,weights] = step(hstap,rxsig,tgtcell);

```

Plot the resulting array output after beamforming.

```

figure;
plot([tgtrng,tgtrng],[0 5e-6],'-.',rangebins,abs(y));
axis tight;
title('SMI Beamformer Output');
xlabel('Range (meters)'); ylabel('Magnitude');

```

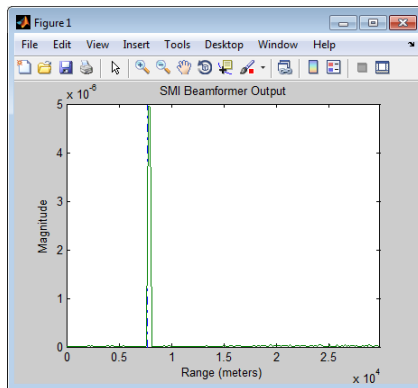

Plot the angle-Doppler response with the beamforming weights.

```

% Construct an angle-Doppler response object and apply the
% beamforming weights
hresp = phased.AngleDopplerResponse('SensorArray',hula,...
    'OperatingFrequency',4e9,'PRF',PRF,...
    'PropagationSpeed',physconst('LightSpeed'));
figure;
plotResponse(hresp,weights);
title('Angle-Doppler Response with SMI Beamforming Weights');

```

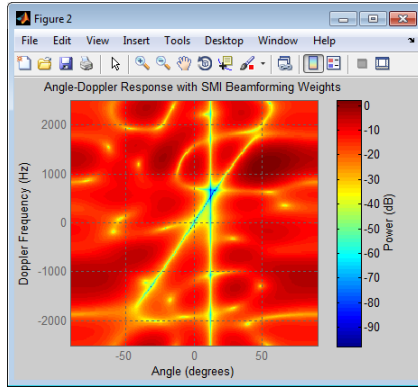

Detection

- “Neyman-Pearson Hypothesis Testing” on page 8-2
- “Receiver Operating Characteristic (ROC) Curves” on page 8-6
- “Matched Filtering” on page 8-11
- “Stretch Processing” on page 8-17
- “FMCW Range Estimation” on page 8-19
- “Range-Doppler Response” on page 8-21
- “Constant False-Alarm Rate (CFAR) Detectors” on page 8-27

Neyman-Pearson Hypothesis Testing

In this section...

“Purpose of Hypothesis Testing” on page 8-2

“Support for Neyman-Pearson Hypothesis Testing” on page 8-2

“Threshold for Real-Valued Signal in White Gaussian Noise” on page 8-3

“Threshold for Two Pulses of Real-Valued Signal in White Gaussian Noise” on page 8-4

“Threshold for Complex-Valued Signals in Complex White Gaussian Noise” on page 8-5

Purpose of Hypothesis Testing

In phased-array applications, you sometimes need to decide between two competing hypotheses to determine the reality underlying the data the array receives. For example, suppose one hypothesis, called the *null hypothesis*, states that the observed data consists of noise only. Suppose another hypothesis, called the *alternative hypothesis*, states that the observed data consists of a deterministic signal plus noise. To decide, you must formulate a decision rule that uses specified criteria to choose between the two hypotheses.

Support for Neyman-Pearson Hypothesis Testing

When you use Phased Array System Toolbox software for applications such as radar and sonar, you typically use the Neyman-Pearson (NP) optimality criterion to formulate your hypothesis test.

When you choose the NP criterion, you can use `npwgntthresh` to determine the threshold for the detection of deterministic signals in white Gaussian noise. The optimal decision rule derives from a *likelihood ratio test* (LRT). An LRT chooses between the null and alternative hypotheses based on a ratio of conditional probabilities.

`npwgntthresh` enables you to specify the maximum false-alarm probability as a constraint. A *false alarm* means determining that the data consists of a signal plus noise, when only noise is present.

For details about the statistical assumptions the `npwgnthresh` function makes, see the reference page for that function.

Threshold for Real-Valued Signal in White Gaussian Noise

This example shows how to verify the probability of false alarm empirically for a real-valued signal in white Gaussian noise.

Determine the required signal-to-noise (SNR) in decibels for the NP detector when the maximum tolerable false-alarm probability is 10^{-3} .

```
Pfa = 1e-3;
T = npwgnthresh(Pfa,1,'real');
```

Determine the actual threshold corresponding to the desired false-alarm probability, assuming the variance is 1.

```
variance = 1;
threshold = sqrt(variance * db2pow(T));
```

Verify empirically that the threshold results in the desired false-alarm probability under the null hypothesis. To do so, generate 1 million samples of a Gaussian random variable, and determine the proportion of samples that exceed the threshold.

```
rng default
N = 1e6;
x = sqrt(variance) * randn(N,1);
falsealarmrate = sum(x > threshold)/N
```

```
falsealarmrate =
```

```
9.9500e-04
```

Plot the first 10,000 samples and a line showing the threshold.

```
x1 = x(1:1e4);
plot(x1)
line([1 length(x1)],[threshold threshold],'Color','red');
xlabel('Sample'); ylabel('Value');
```

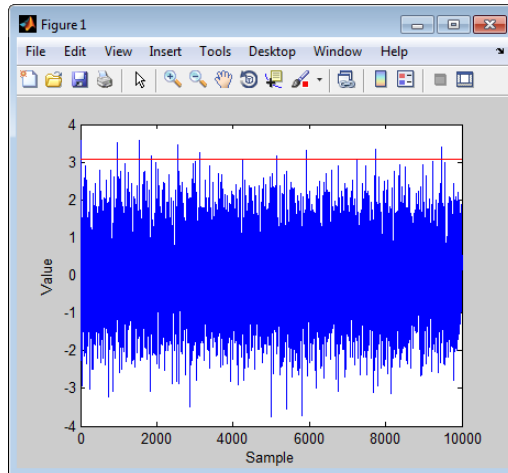

The red horizontal line in the plot indicates the threshold. You can see that few sample values exceed the threshold. This result is expected because of the small false-alarm probability.

Threshold for Two Pulses of Real-Valued Signal in White Gaussian Noise

This example shows how to verify the probability of false alarm empirically in a system that uses pulse integration with two real-valued pulses. In this scenario, each sample is the sum of two samples, one from each pulse.

Determine the required SNR for the NP detector when the maximum tolerable false-alarm probability is 10^{-3} .

```
Pfa = 1e-3;
T = npwgnthresh(Pfa,2,'real');
```

Generate two sets of 10,000 samples of a Gaussian random variable.

```
rng default
variance = 1;
N = 1e6;
puls1 = sqrt(variance)*randn(N,1);
puls2 = sqrt(variance)*randn(N,1);
```



```
intpuls = puls1 + puls2;
```

Compute the proportion of samples that exceed the threshold.

```
threshold = sqrt(variance*db2pow(T));
falsealarmrate = sum(intpuls > threshold)/N
```

```
falsealarmrate =
```

```
9.8900e-04
```

Threshold for Complex-Valued Signals in Complex White Gaussian Noise

This example shows how to verify the probability of false alarm empirically in a system that uses complex-valued signals. The system uses *coherent detection*, which means that the system has information about the phase of the complex-valued signals.

Determine the required SNR for the NP detector in a coherent detection scheme with one sample. Use a maximum tolerable false-alarm probability of 10^{-3} .

```
Pfa = 1e-3;
T = npwgthresh(Pfa,1,'coherent');
```

Test that this threshold empirically results in the correct false-alarm rate. The sufficient statistic in the complex-valued case is the real part of received sample.

```
rng default
variance = 1;
N = 1e6;
x = sqrt(variance/2)*(randn(N,1)+1j*randn(N,1));
threshold = sqrt(variance*db2pow(T));
falsealarmrate = sum(real(x)>threshold)/length(x)
```

```
falsealarmrate =
```

```
9.9500e-04
```

Receiver Operating Characteristic (ROC) Curves

ROC curves present graphical summaries of a detector's performance. You can generate ROC curves using the functions `rocprfa` and `rocsnr`.

If you are interested in examining the effect of varying the false-alarm probability on the probability of detection for a fixed SNR, you can use `rocsnr`.

For example, the threshold SNR for the Neyman-Pearson detector of a single sample in real-valued Gaussian noise is approximately 13.5 dB. Use `rocsnr` to demonstrate how the probability of detection varies as a function of the false-alarm rate at that SNR.

```
T = npwgntthresh(1e-6,1,'real');
rocsnr(T,'SignalType','real')
```

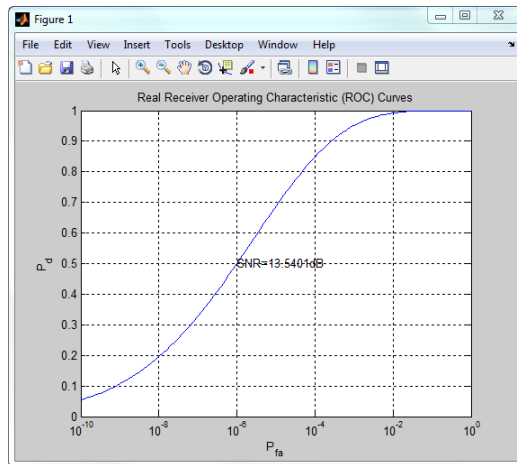

The ROC curve enables you to easily read off the probability of detection for a given false-alarm rate.

You can use `rocsnr` to examine detector performance for different received signal types at a fixed SNR.

```
SNR = 13.54;
[Pd_real,Pfa_real] = rocsnr(SNR,'SignalType','real',...
    'MinPfa',1e-8);
```

```
[Pd_coh,Pfa_coh] = rocsnr(SNR,...
    'SignalType','NonfluctuatingCoherent',...
    'MinPfa',1e-8);
[Pd_noncoh,Pfa_noncoh] = rocsnr(SNR,'SignalType',...
    'NonfluctuatingNoncoherent','MinPfa',1e-8);
figure;
semilogx(Pfa_real,Pd_real); hold on; grid on;
semilogx(Pfa_coh,Pd_coh,'r');
semilogx(Pfa_noncoh,Pd_noncoh,'k');
xlabel('False-Alarm Probability');
ylabel('Probability of Detection');
legend('Real','Coherent','Noncoherent','location','southeast');
title('ROC Curve Comparison for Nonfluctuating RCS Target');
```

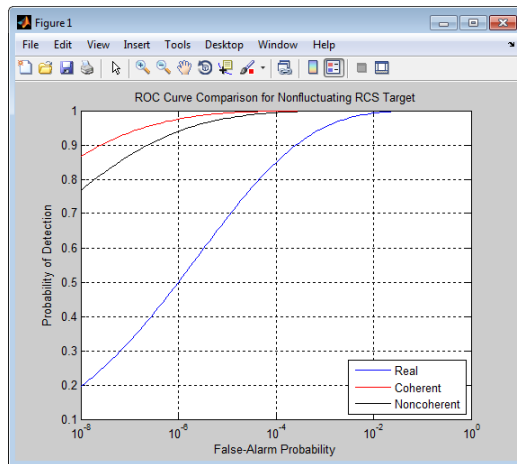

The ROC curves clearly demonstrate the superior probability of detection performance for coherent and noncoherent detectors over the real-valued case.

The `rocsnr` function accepts an SNR vector input enabling you to quickly examine a number of ROC curves.

```
SNRs = (6:2:12);
figure;
rocsnr(SNRs,'SignalType','NonfluctuatingNoncoherent');
```

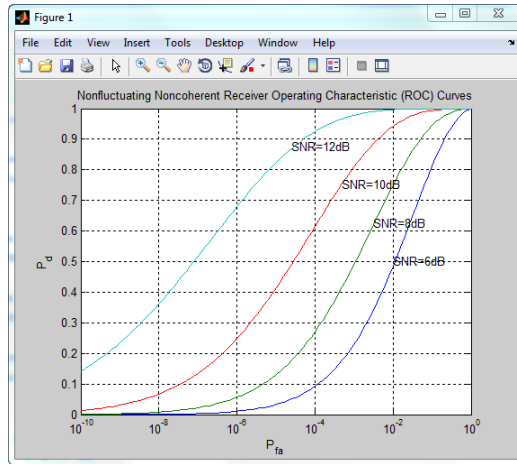

The graph shows that—as the SNR increases—the supports of the probability distributions under the null and alternative hypotheses become more disjoint. Therefore, for a given false-alarm probability, the probability of detection increases.

You can examine the probability of detection as a function of SNR for a fixed false-alarm probability with `rocnpfa`.

To obtain ROC curves for a Swerling I target model at false-alarm probabilities of [1e-6 1e-4 1e-2 1e-1], enter:

```
Pfa = [1e-6 1e-4 1e-2 1e-1];
figure;
rocnpfa(Pfa, 'SignalType', 'Swerling1');
```

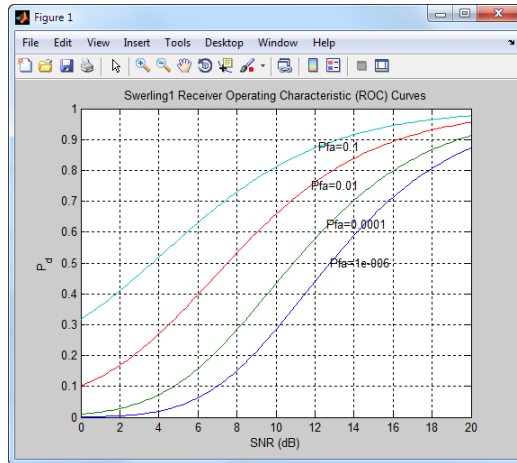

Use `rocpfa` to examine the effect of SNR on the probability of detection for a detector using noncoherent integration with a false-alarm probability of $1e-4$. Assume the target has a nonfluctuating RCS and that you are integrating over 5 pulses.

```
[Pd,SNR] = rocpfa(1e-4,...
    'SignalType','NonfluctuatingNoncoherent',...
    'NumPulses',5);
figure;
plot(SNR,Pd); xlabel('SNR (dB)');
ylabel('Probability of Detection'); grid on;
title('Nonfluctuating Noncoherent Detector (5 Pulses)');
```

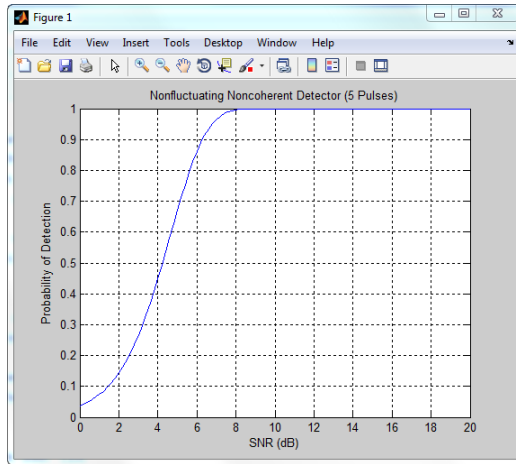

Related Examples

- Detector Performance Analysis using ROC Curves

Matched Filtering

In this section...

“Reasons for Using Matched Filtering” on page 8-11

“Support for Matched Filtering” on page 8-11

“Matched Filtering of Linear FM Waveform” on page 8-11

“Matched Filtering to Improve SNR for Target Detection” on page 8-13

Reasons for Using Matched Filtering

You can see from the results in “Receiver Operating Characteristic (ROC) Curves” on page 8-6 that the probability of detection increases with increasing SNR. For a deterministic signal in white Gaussian noise, you can maximize the SNR at the receiver by using a filter matched to the signal. The matched filter is a time-reversed and conjugated version of the signal. The matched filter is shifted to be causal.

Support for Matched Filtering

Use `phased.MatchedFilter` to implement a matched filter.

When you use `phased.MatchedFilter`, you can customize characteristics of the matched filter such as the matched filter coefficients and window for spectrum weighting. If you apply spectrum weighting, you can specify the coverage region and coefficient sample rate; Taylor, Chebyshev, and Kaiser windows have additional properties you can specify.

Matched Filtering of Linear FM Waveform

This example shows how to compare the results of matched filtering with and without spectrum weighting. Spectrum weighting is often used with linear FM waveforms to reduce the sidelobes in the time domain.

Create a linear FM waveform with a duration of 0.1 milliseconds, a sweep bandwidth of 100 kHz, and a pulse repetition frequency of 5 kHz. Add noise to the linear FM pulse and filter the noisy signal using a matched filter. This example applies a matched filter with and without spectrum weighting.

```
% Specify the waveform.
hwav = phased.LinearFMWaveform('PulseWidth',1e-4,'PRF',5e3,...
    'SampleRate',1e6,'OutputFormat','Pulses','NumPulses',1,...
    'SweepBandwidth',1e5);
w = getMatchedFilter(hwav);

% Create a matched filter with no spectrum weighting, and a
% matched filter that uses a Taylor window for spectrum
% weighting.
hmf = phased.MatchedFilter('Coefficients',w);
hmf_taylor = phased.MatchedFilter('Coefficients',w,...
    'SpectrumWindow','Taylor');

% Create the signal and add noise.
sig = step(hwav);
rng(17)
x = sig+0.5*(randn(length(sig),1)+1j*randn(length(sig),1));

% Filter the noisy signal separately with each of the filters.
y = step(hmf,x);
y_taylor = step(hmf_taylor,x);

% Plot the real parts of the waveform and noisy signal.
t = linspace(0,numel(sig)/hwav.SampleRate,...
    hwav.SampleRate/hwav.PRF);
subplot(2,1,1);
plot(t,real(sig)); title('Input Signal');
xlim([0 max(t)]); grid on
ylabel('Amplitude');
subplot(2,1,2);
plot(t,real(x)); title('Input Signal + Noise');
xlim([0 max(t)]); grid on
xlabel('Seconds'); ylabel('Amplitude');

% Plot the magnitudes of the two matched filter outputs.
figure;
plot(t,abs(y),'b--');
title('Matched Filter Output');
xlim([0 max(t)]); grid on
hold on;
```



```

plot(t,abs(y_taylor),'r-');
ylabel('Magnitude'); xlabel('Seconds');
legend('No Spectrum Weighting','Taylor Window');
hold off;

```

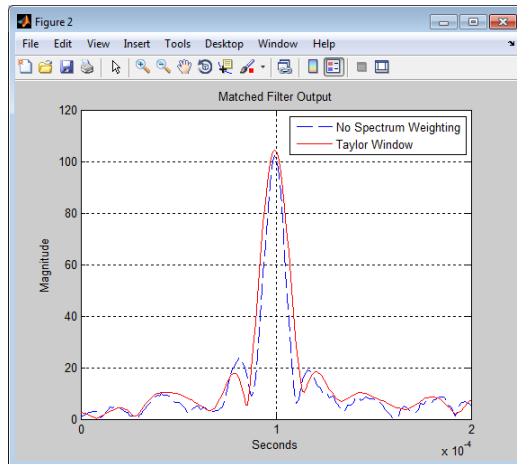
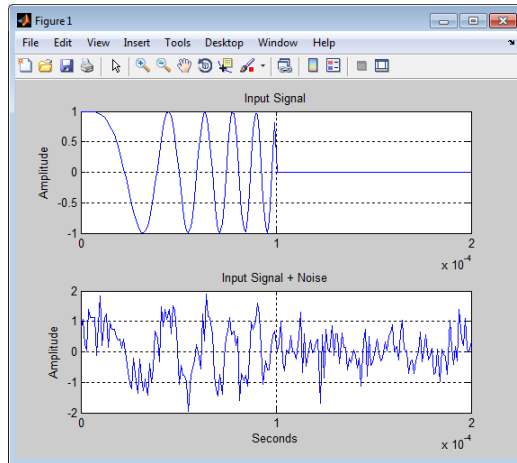

Matched Filtering to Improve SNR for Target Detection

This example shows how to improve the SNR by performing matched filtering.

Place an isotropic antenna element at the global origin [0;0;0]. Then, place a target with a nonfluctuating RCS of 1 square meter at [5000;5000;10], which is approximately 7 km from the transmitter. Set the operating (carrier) frequency to 10 GHz. To simulate a monostatic radar, set the `InUseOutputPort` property on the transmitter to `true`. Calculate the range and angle from the transmitter to the target.

```
hsensor = phased.IsotropicAntennaElement(...
    'FrequencyRange',[5e9 15e9]);
htx = phased.Transmitter('Gain',20,'InUseOutputPort',true);
fc = 10e9;
htgt = phased.RadarTarget('Model','Nonfluctuating',...
    'MeanRCS',1,'OperatingFrequency',fc);
txloc = [0;0;0];
tgtloc = [5000;5000;10];
htxloc = phased.Platform('InitialPosition',txloc);
htgtloc = phased.Platform('InitialPosition',tgtloc);
[tgtrng,tgtang] = rangeangle(htgtloc.InitialPosition,...
    htxloc.InitialPosition);
```

Create a rectangular pulse waveform 25 μ s in duration with a PRF of 10 kHz. Use a single pulse for this example. Determine the maximum unambiguous range for the given PRF. Use the `radareqpow` function to determine the peak power required to detect a target. This target has an RCS of 1 square meter at the maximum unambiguous range for the transmitter operating frequency and gain. The SNR is based on a desired false-alarm rate of $1e-6$ for a noncoherent detector.

```
hwav = phased.RectangularWaveform('PulseWidth',25e-6,...
    'OutputFormat','Pulses','PRF',1e4,'NumPulses',1);
c = physconst('LightSpeed');
maxrange = c/(2*hwav.PRF);
SNR = npwgnthresh(1e-6,1,'noncoherent');
Pt = radareqpow(c/fc,maxrange,SNR,...
    hwav.PulseWidth,'RCS',htgt.MeanRCS,'Gain',htx.Gain);
```

Set the peak transmit power to the output value from `radareqpow`.

```
htx.PeakPower = Pt;
```

Create radiator and collector objects that operate at 10 GHz. Create a free space path for the propagation of the pulse to and from the target. Then, create a receiver and a matched filter for the rectangular waveform.

```
hrad = phased.Radiator('PropagationSpeed',c,...
    'OperatingFrequency',fc,'Sensor',hsensor);
hspace = phased.FreeSpace('PropagationSpeed',c,...
    'OperatingFrequency',fc,'TwoWayPropagation',false);
hcol = phased.Collector('PropagationSpeed',c,...
    'OperatingFrequency',fc,'Sensor',hsensor);
hrec = phased.ReceiverPreamp('NoiseFigure',0,...
    'EnableInputPort',true,'SeedSource','Property','Seed',2e3);
hmf = phased.MatchedFilter(...
    'Coefficients',getMatchedFilter(hwav),...
    'GainOutputPort',true);
```

After you create all the objects that define your model, you can propagate the pulse to and from the target. Collect the echo at the receiver, and implement the matched filter to improve the SNR.

```
% Generate waveform
wf = step(hwav);
% Transmit waveform
[wf,txstatus] = step(htx,wf);
% Radiate pulse toward the target
wf = step(hrad,wf,tgtang);
% Propagate pulse toward the target
wf = step(hspace,wf,txloc,tgtloc,[0;0;0],[0;0;0]);
% Reflect it off the target
wf = step(htgt,wf);
% Propagate the pulse back to transmitter
wf = step(hspace,wf,tgtloc,txloc,[0;0;0],[0;0;0]);
% Collect the echo
wf = step(hcol,wf,tgtang);

% Receive target echo
rx_puls = step(hrec,wf,-txstatus);
[mf_puls,mfgain] = step(hmf,rx_puls);
% Get group delay of matched filter
Gd = length(hmf.Coefficients)-1;
% The group delay is constant
```

```
% Shift the matched filter output
mf_puls=[mf_puls(Gd+1:end); mf_puls(1:Gd)];
subplot(2,1,1);
t = unigrid(0,1e-6,1e-4, '[]');
rangegates = c.*t;
rangegates = rangegates/2;
plot(rangegates,abs(rx_puls)); title('Received Pulse');
ylabel('Amplitude'); hold on;
plot([tgtrng, tgtrng], [0 max(abs(rx_puls))], 'r');
subplot(2,1,2)
plot(rangegates,abs(mf_puls)); title('With Matched Filtering');
xlabel('Meters'); ylabel('Amplitude'); hold on;
plot([tgtrng, tgtrng], [0 max(abs(mf_puls))], 'r');
```

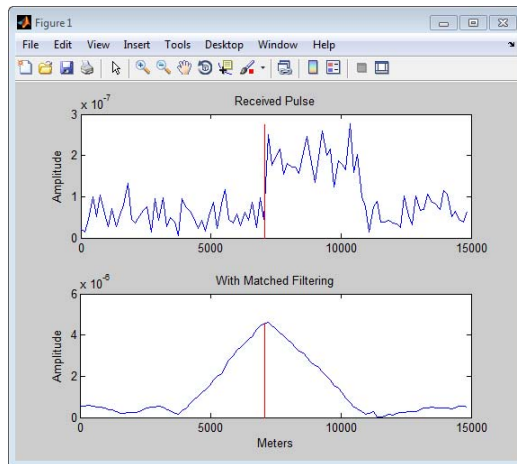

Stretch Processing

In this section...

“Reasons for Using Stretch Processing” on page 8-17

“Support for Stretch Processing” on page 8-17

“Stretch Processing Procedure” on page 8-17

Reasons for Using Stretch Processing

The linear FM waveform is popular in radar systems because its large time-bandwidth product can provide good range resolution. However, the large bandwidth of this waveform makes digital matched filtering difficult because it requires expensive, high-quality analog-to-digital converters. *Stretch processing*, also known as *deramping*, or *dechirping*, is an alternative to matched filtering. Stretch processing provides pulse compression by looking for the return within a predefined range interval of interest. Stretch processing typically occurs in the analog domain. Unlike matched filtering, stretch processing reduces the bandwidth requirement of subsequent processing.

Support for Stretch Processing

The `phased.StretchProcessor` System object implements stretch processing. You can use this object as part of a simulation that uses `phased.LinearFMWaveform` or directly with your own data.

Stretch Processing Procedure

The typical procedure for stretch processing is as follows:

- 1 Choose a range interval of interest, centered on a reference range. Stretch processing focuses on this interval instead of the entire range span that the pulse can cover.
- 2 Define and configure a stretch processor object. The configuration includes the reference range, length of the range interval of interest, characteristics of the linear FM waveform, and signal propagation speed.

- If you are using a `phased.LinearFMWaveform` object to implement the linear FM waveform, use the `getStretchProcessor` method to define and automatically configure a stretch processor object.
 - Otherwise, create a `phased.StretchProcessor` object directly, and set its properties as needed.
- 3** Perform stretch processing by calling the `step` method on your stretch processor object. You provide your received signal as an input argument. The `step` method generates a reference signal and correlates it with your received signal.
 - 4** Compute a periodogram of the output from `step`, and identify the peak frequencies. You can use the following features to help you perform this step:
 - `periodogram`
 - `psd`
 - `findpeaks`
 - 5** Convert each peak frequency to the corresponding range value, using the `stretchfreq2rng` function.

See Also

`phased.StretchProcessor` | `phased.LinearFMWaveform` | `stretchfreq2rng`
| `periodogram` | `findpeaks`

Related Examples

- Range Estimation Using Stretch Processing

FMCW Range Estimation

The purpose of FMCW range estimation is to estimate the range of a target. For example, a radar for collision avoidance in an automobile needs to estimate the distance to the nearest obstacle. FMCW range estimation algorithms can vary in the details, but the typical high-level procedure is as follows:

- 1 Dechirp** — Dechirp the the received signal by mixing it with the transmitted signal. If you use the `dechirp` function, the transmitted signal is the reference signal.
- 2 Find beat frequency** — From the dechirped signal, extract the beat frequency or pair of beat frequencies. If the FMCW signal has a sawtooth shape (up-sweep or down-sweep sawtooth shape), you extract one beat frequency. If the FMCW signal has a triangular sweep, you extract up-sweep and down-sweep beat frequencies.

Extracting beat frequencies can use a variety of algorithms. For example, you can use the following features to help you perform this step:

- `pwelch` or `periodogram`
 - `psd`
 - `findpeaks`
 - `rootmusic`
 - `phased.CFARDetector`
- 3 Compute range** — Use the beat frequency or frequencies to compute the corresponding range value. The `beat2range` function can perform this computation.

While developing your algorithm, you might also perform these auxiliary tasks:

- Visualize targets in the range-Doppler domain, using the `phased.RangeDopplerResponse` System object.
- Determine whether you need to compensate for range-Doppler coupling. Such coupling can occur if the target is moving relative to the radar.

You can use the `rdcoupling` function to compute the range offset due to range-Doppler coupling. If the range offset is not negligible, common compensation techniques include:

- Subtracting the range offset from your initial range estimate
- Having the FMCW signal use a triangle sweep instead of an up sweep or down sweep
- Explore the relationships among your system's range requirements and parameters of the FMCW waveform. You can use these functions:
 - `range2time`
 - `time2range`
 - `range2bw`

See Also

`phased.FMCWWaveform` | `phased.RangeDopplerResponse` | `time2range` | `range2time` | `range2bw` | `dechirp` | `beat2range` | `range2beat` | `rdcoupling` | `periodogram` | `findpeaks` | `pwelch` | `rootmusic`

Related Examples

- Automotive Adaptive Cruise Control Using FMCW Technology

Range-Doppler Response

In this section...

“Benefits of Producing Range-Doppler Response” on page 8-21

“Support for Range-Doppler Processing” on page 8-21

“Range-Speed Response Pattern of Target” on page 8-23

Benefits of Producing Range-Doppler Response

Visualizing a signal in the range-Doppler domain can help you intuitively understand connections among targets. From a range-Doppler map, you can:

- See how far away the targets are and how quickly they are approaching or receding.
- Distinguish among targets moving at various speeds at various ranges, in particular:
 - If a transmitter platform is stationary, a range-Doppler map shows a response from stationary targets at zero Doppler.
 - For targets that are moving relative to the transmitter platform, the range-Doppler map shows a response at nonzero Doppler values.

You can also use the range-Doppler response in nonvisual ways. For example, you can perform peak detection in the range-Doppler domain and use the information to resolve the range-Doppler coupling of an FMCW radar system.

Support for Range-Doppler Processing

You can use the `phased.RangeDopplerResponse` object to compute and visualize the range-Doppler response of input data. This object performs range processing in fast time, followed by Doppler processing in slow time. The object configuration and syntax typically depend on the kind of radar system.

Pulsed Radar Systems

This procedure is used typically to produce a range-Doppler response for a pulsed radar system. (In the special case of linear FM pulses, the procedure in “FMCW Radar Systems” on page 8-22 is an alternative option.)

- 1** Create a `phased.RangeDopplerResponse` object, setting the `RangeMethod` property to `'Matched Filter'`.
- 2** Customize these characteristics, or accept default values for any of them:
 - Signal propagation speed
 - Sample rate
 - Length of the FFT for Doppler processing
 - Characteristics of the window for Doppler weighting, if any
 - Doppler domain output preference in terms of radial speed or Doppler shift frequency. (If you select radial speed, also specify the signal carrier frequency.)
- 3** Organize your data, `x`, into a matrix. The columns in this matrix correspond to separate, consecutive pulses.
- 4** Use `plotResponse` to plot the range-Doppler response or `step` to obtain data representing the range-Doppler response. Include `x` and matched filter coefficients in your syntax when you call `plotResponse` or `step`.

For examples, see the `step` reference page or “Range-Speed Response Pattern of Target” on page 8-23.

FMCW Radar Systems

This procedure is used typically to produce a range-Doppler response for an FMCW radar system. You can also use this procedure for a system that uses linear FM pulsed signals. In the case of pulsed signals, you typically use stretch processing to dechirp the signal.

- 1** Create a `phased.RangeDopplerResponse` object, setting the `RangeMethod` property to `'Dechirp'`.
- 2** Customize these characteristics, or accept default values for any of them:
 - Signal propagation speed
 - Sample rate
 - FM sweep slope

- Whether the processor should dechirp or decimate your signal
 - Length of the FFT for range processing. The algorithm performs an FFT to translate the dechirped data into the beat frequency domain, which provides range information.
 - Characteristics of the window for range weighting, if any
 - Length of the FFT for Doppler processing
 - Characteristics of the window for Doppler weighting, if any
 - Doppler domain output preference in terms of radial speed or Doppler shift frequency. (If you select radial speed, also specify the signal carrier frequency.)
- 3** Organize your data, `x`, into a matrix in which the columns correspond to sweeps or pulses that are separate and consecutive.

In the case of an FMCW waveform with a triangle sweep, the sweeps alternate between positive and negative slopes. However, `phased.RangeDopplerResponse` is designed to process consecutive sweeps of the same slope. To apply `phased.RangeDopplerResponse` for a triangle-sweep system, use one of the following approaches:

- Specify a positive `SweepSlope` property value, with `x` corresponding to upsweeps only. The true values of Doppler or speed are half of what `step` returns or `plotResponse` plots.
 - Specify a negative `SweepSlope` property value, with `x` corresponding to downsweeps only. The true values of Doppler or speed are half of what `step` returns or `plotResponse` plots.
- 4** Use `plotResponse` to plot the range-Doppler response or `step` to obtain data representing the range-Doppler response. Include `x` in the syntax when you call `plotResponse` or `step`. If your data is not already dechirped, also include a reference signal in the syntax.

For an example, see the `plotResponse` reference page.

Range-Speed Response Pattern of Target

This example shows how to visualize the speed and range of a target in a pulsed radar system that uses a rectangular waveform.

Place an isotropic antenna element at the global origin [0;0;0]. Then, place a target with a nonfluctuating RCS of 1 square meter at [5000;5000;10], which is approximately 7 km from the transmitter. Set the operating (carrier) frequency to 10 GHz. To simulate a monostatic radar, set the `InUseOutputPort` property on the transmitter to `true`. Calculate the range and angle from the transmitter to the target.

```
hsensor = phased.IsotropicAntennaElement(...
    'FrequencyRange',[5e9 15e9]);
htx = phased.Transmitter('Gain',20,'InUseOutputPort',true);
fc = 10e9;
htgt = phased.RadarTarget('Model','Nonfluctuating',...
    'MeanRCS',1,'OperatingFrequency',fc);
txloc = [0;0;0];
tgtloc = [5000;5000;10];
htxloc = phased.Platform('InitialPosition',txloc);
htgtloc = phased.Platform('InitialPosition',tgtloc);
[tgtrng,tgtang] = rangeangle(htgtloc.InitialPosition,...
    htxloc.InitialPosition);
```

Create a rectangular pulse waveform 2 μ s in duration with a PRF of 10 kHz. Determine the maximum unambiguous range for the given PRF. Use the `radareqpow` function to determine the peak power required to detect a target. This target has an RCS of 1 square meter at the maximum unambiguous range for the transmitter operating frequency and gain. The SNR is based on a desired false-alarm rate of $1e-6$ for a noncoherent detector.

```
hwav = phased.RectangularWaveform('PulseWidth',2e-6,...
    'OutputFormat','Pulses','PRF',1e4,'NumPulses',1);
c = physconst('LightSpeed');
maxrange = c/(2*hwav.PRF);
SNR = npwgnthresh(1e-6,1,'noncoherent');
Pt = radareqpow(c/fc,maxrange,SNR,...
    hwav.PulseWidth,'RCS',htgt.MeanRCS,'Gain',htx.Gain);
```

Set the peak transmit power to the output value from `radareqpow`.

```
htx.PeakPower = Pt;
```

Create radiator and collector objects that operate at 10 GHz. Create a free space path for the propagation of the pulse to and from the target. Then, create a receiver.

```

hrad = phased.Radiator(...
    'PropagationSpeed',c,...
    'OperatingFrequency',fc,'Sensor',hsensor);
hspace = phased.FreeSpace(...
    'PropagationSpeed',c,...
    'OperatingFrequency',fc,'TwoWayPropagation',false);
hcol = phased.Collector(...
    'PropagationSpeed',c,...
    'OperatingFrequency',fc,'Sensor',hsensor);
hrec = phased.ReceiverPreamp('NoiseFigure',0,...
    'EnableInputPort',true,'SeedSource','Property','Seed',2e3);

```

Propagate 25 pulses to and from the target. Collect the echoes at the receiver, and store them in a 25-column matrix named rx_puls.

```

numPulses = 25;
rx_puls = zeros(100,numPulses);
for n = 1:numPulses
    % Generate waveform
    wf = step(hwav);
    % Transmit waveform
    [wf,txstatus] = step(htx,wf);
    % Radiate pulse toward the target
    wf = step(hrad,wf,tgtang);
    % Propagate pulse toward the target
    wf = step(hspace,wf,txloc,tgtloc,[0;0;0],[0;0;0]);
    % Reflect it off the target
    wf = step(htgt,wf);
    % Propagate the pulse back to transmitter
    wf = step(hspace,wf,tgtloc,txloc,[0;0;0],[0;0;0]);
    % Collect the echo
    wf = step(hcol,wf,tgtang);
    % Receive target echo
    rx_puls(:,n) = step(hrec,wf,~txstatus);
end

```

Create a range-Doppler response object that uses the matched filter approach. Configure this object to show radial speed rather than Doppler frequency. Use `plotResponse` to plot the range versus speed.

```
hrdr = phased.RangeDopplerResponse(...
    'RangeMethod','Matched Filter',...
    'PropagationSpeed',c,...
    'DopplerOutput','Speed','OperatingFrequency',fc);
plotResponse(hrdr,rx_puls,getMatchedFilter(hwav))
```

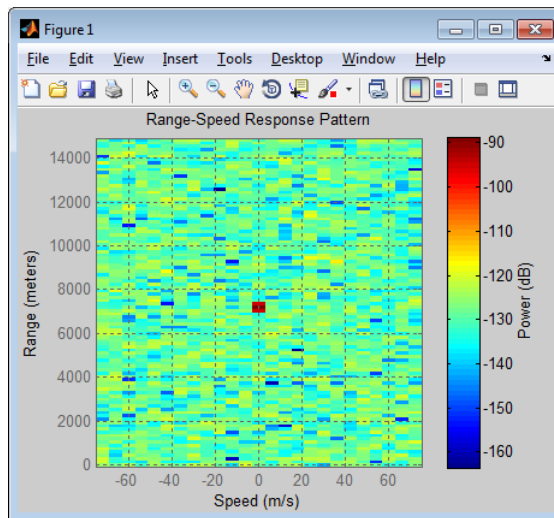

The plot shows the stationary target at a range of approximately 7000 m.

See Also `phased.RangeDopplerResponse` |

Related Examples

- Automotive Adaptive Cruise Control Using FMCW Technology

Constant False-Alarm Rate (CFAR) Detectors

In this section...

“Reasons for Using CFAR Detectors” on page 8-27

“Cell-Averaging CFAR Detector” on page 8-28

“Testing CFAR Detector Adaption to Noisy Input Data” on page 8-30

“Extensions of Cell-Averaging CFAR Detector” on page 8-31

“Detection Probability for CFAR Detector” on page 8-32

Reasons for Using CFAR Detectors

In the Neyman-Pearson framework, the probability of detection is maximized subject to the constraint that the false-alarm probability does not exceed a specified level. The false-alarm probability depends on the noise variance. Therefore, to calculate the false-alarm probability, you must first estimate the noise variance. If the noise variance changes, you must adjust the threshold to maintain a constant false-alarm rate. *Constant false-alarm rate detectors* implement adaptive procedures that enable you to update the threshold level of your test when the power of the interference changes.

To motivate the need for an adaptive procedure, assume a simple binary hypothesis test where you must decide between these hypotheses for a single sample:

$$H_0 : x[0] = w[0] \quad w[0] \sim N(0,1)$$

$$H_1 : x[0] = 4 + w[0]$$

Set the false-alarm rate to 0.001 and determine the threshold.

```
T = npwgnthresh(1e-3,1,'real');
threshold = sqrt(db2pow(T))
```

Check that this threshold yields the desired false-alarm rate probability, and compute the probability of detection.

```
% check false-alarm probability
Pfa = 0.5*erfc(threshold/sqrt(2))
```

```
% compute probability of detection
Pd = 0.5*erfc((threshold-4)/sqrt(2))
```

Next, assume that the noise power increases by 6.02 dB, doubling the noise variance. If your detector does not adapt to this increase in variance by determining a new threshold, your false-alarm rate increases significantly.

```
Pfa = 0.5*erfc(threshold/2)
```

The following figure demonstrates the effect of increasing the noise variance on the false-alarm probability for a fixed threshold.

```
noisevar = 1:0.1:10;
Noisepower = 10*log10(noisevar);
Pfa = 0.5*erfc(threshold./sqrt(2*noisevar));
semilogy(Noisepower,Pfa./1e-3);
grid on; title('Increase in P_{FA} due to Noise Variance');
ylabel('Increase in P_{FA} (Orders of Magnitude)');
xlabel('Noise Power Increase (dB)');
```

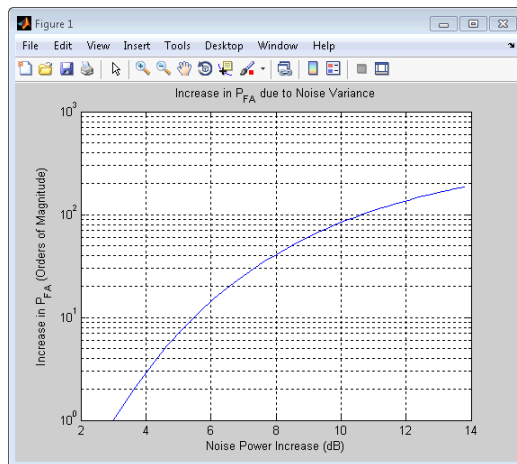

Cell-Averaging CFAR Detector

The cell-averaging CFAR detector estimates the noise variance for the range cell of interest, or *cell under test*, by analyzing data from neighboring range cells designated as *training cells*. The noise characteristics in the training

cells are assumed to be identical to the noise characteristics in the cell under test (CUT).

This assumption is key in justifying the use of the training cells to estimate the noise variance in the CUT. Additionally, the cell-averaging CFAR detector assumes that the training cells do not contain any signals from targets. Thus, the data in the training cells are assumed to consist of noise only.

To make these assumptions realistic:

- It is preferable to have some buffer, or *guard cells*, between the CUT and the training cells. The buffer provided by the guard cells *guards* against signal leaking into the training cells and adversely affecting the estimation of the noise variance.
- The training cells should not represent range cells too distant in range from the CUT, as the following figure illustrates.

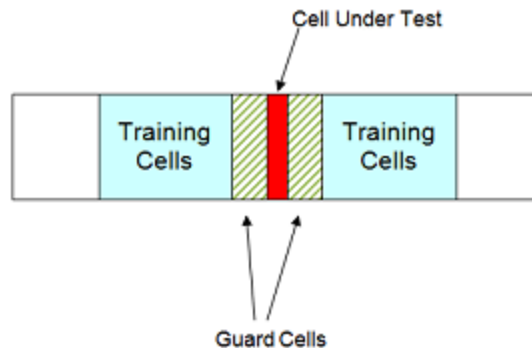

The optimum estimator for the noise variance depends on distributional assumptions and the type of detector. Assume the following:

- 1** You are using a square-law detector.
- 2** You have a Gaussian, complex-valued, random variable (RV) with independent real and imaginary parts.

- 3** The real and imaginary parts each have mean zero and variance equal to $\sigma^2/2$.

Note If you denote this RV by $Z=U+jV$, the squared magnitude $|Z|^2$ follows an exponential distribution with mean σ^2 .

If the samples in training cells are the squared magnitudes of such complex Gaussian RVs, you can use the sample mean as an estimator of the noise variance.

To implement cell-averaging CFAR detection, use `phased.CFARDetector`. You can customize characteristics of the detector such as the numbers of training cells and guard cells, and the probability of false alarm.

Testing CFAR Detector Adaption to Noisy Input Data

This example shows how to create a CFAR detector and test its ability to adapt to the statistics of input data. The test uses noise-only trials. By using the default square-law detector, you can determine how close the empirical false-alarm rate is to the desired false-alarm probability.

Create a CFAR detector object with two guard cells, 20 training cells, and a false-alarm probability of 0.001. By default, this object assumes a square-law detector with no pulse integration.

```
hdetector = phased.CFARDetector('NumGuardCells',2,...
    'NumTrainingCells',20,'ProbabilityFalseAlarm',1e-3);
```

There are 10 training cells and 1 guard cell on each side of the cell under test (CUT). Set the CUT index to 12.

```
CUTidx = 12;
```

Seed the random number generator for a reproducible set of input data.

```
rng(1000);
```

Set the noise variance to 0.25. This value corresponds to an approximate -6 dB SNR. Generate a 23-by-10000 matrix of complex-valued, white Gaussian

RVs with the specified variance. Each row of the matrix represents 10,000 Monte Carlo trials for a single cell.

```
Ntrials = 1e4;
variance = 0.25;
Ncells = 23;
inputdata = sqrt(variance/2)*(randn(Ncells,Ntrials)+...
    1j*randn(Ncells,Ntrials));
```

Because the example implements a square-law detector, take the squared magnitudes of the elements in the data matrix.

```
Z = abs(inputdata).^2;
```

Provide the output of the square-law operator and the index of the cell under test to CFAR detector's `step` method.

```
Z_detect = step(hdetector,Z,CUTidx);
```

The output is a logical vector `Z_detect` with 10,000 elements. Sum the elements in `Z_detect` and divide by the total number of trials to obtain the empirical false-alarm rate.

```
Pfa = sum(Z_detect)/Ntrials
```

The empirical false-alarm rate is 0.0013, which corresponds closely to the desired false-alarm rate of 0.001.

Extensions of Cell-Averaging CFAR Detector

The cell-averaging algorithm for a CFAR detector works well in many situations, but not all. For example, when targets are closely located, cell averaging can cause a strong target to mask a weak target nearby. `phased.CFARDetector` supports the CFAR detection algorithms in the next table.

Algorithm	Typical Usage
Cell-averaging CFAR	Most situations
Greatest-of cell-averaging CFAR	When it is important to avoid false alarms at the edge of clutter

Algorithm	Typical Usage
Smallest-of cell-averaging CFAR	When targets are closely located
Order statistic CFAR	Compromise between greatest-of and smallest-of cell averaging

Detection Probability for CFAR Detector

This example shows how to compare the probability of detection resulting from two CFAR algorithms. In this scenario, the order statistic algorithm detects a target that the cell-averaging algorithm does not.

Create a CFAR detector that uses the cell-averaging CFAR algorithm.

```
Ntraining = 10;
Nguard = 2;
Pfa_goal = 0.01;
hdet = phased.CFARDetector('Method','CA',...
    'NumTrainingCells',Ntraining,'NumGuardCells',Nguard,...
    'ProbabilityFalseAlarm',Pfa_goal);
```

The detector has 2 guard cells, 10 training cells, and a false-alarm probability of 0.01. This object assumes a square-law detector with no pulse integration.

Generate a vector of input data based on a complex-valued white Gaussian random variable.

```
Ncells = 23;
Ntrials = 100000;
inputdata = 1/sqrt(2)*(randn(Ncells,Ntrials) + ...
    1i*randn(Ncells,Ntrials));
```

In the input data, replace rows 8 and 12 to simulate two targets for the CFAR detector to detect.

```
inputdata(8,:) = 3*exp(1i*2*pi*rand);
inputdata(12,:) = 9*exp(1i*2*pi*rand);
```

Because the example implements a square-law detector, take the squared magnitudes of the elements in the input data vector.

```
Z = abs(inputdata).^2;
```

Perform the detection on rows 8 through 12.

```
Z_detect = step(hdet,Z,8:12);
```

The `Z_detect` matrix has five rows. The first and last rows correspond to the simulated targets. The three middle rows correspond to noise.

Compute the probability of detection of the two targets. Also, estimate the probability of false alarm using the noise-only rows.

```
Pd_1 = sum(Z_detect(1,:))/Ntrials
Pd_2 = sum(Z_detect(end,:))/Ntrials
Pfa = max(sum(Z_detect(2:end-1,:),2)/Ntrials)
```

```
Pd_1 =
```

```
0
```

```
Pd_2 =
```

```
1
```

```
Pfa =
```

```
6.0000e-05
```

The 0 value of `Pd_1` indicates that this detector does not detect the first target.

Change the CFAR detector so it uses the order statistic CFAR algorithm with a rank of 5.

```
release(hdet);
hdet.Method = 'OS';
hdet.Rank = 5;
```

Repeat the detection and probability computations.

```
Z_detect = step(hdet,Z,8:12);
```

```
Pd_1 = sum(Z_detect(1,:))/Ntrials  
Pd_2 = sum(Z_detect(end,:))/Ntrials  
Pfa = max(sum(Z_detect(2:end-1,:),2)/Ntrials)
```

```
Pd_1 =  
0.5820
```

```
Pd_2 =  
1
```

```
Pfa =  
0.0066
```

Using the order statistic algorithm instead of the cell-averaging algorithm, the detector detects the first target in about 58% of the trials.

Environment and Target Models

- “Free Space Path Loss” on page 9-2
- “Radar Target” on page 9-9
- “Clutter Modeling” on page 9-13
- “Barrage Jammer” on page 9-17

Free Space Path Loss

In this section...
“Support for Modeling Propagation in Free Space” on page 9-2
“Free Space Path Loss in Decibels” on page 9-3
“Propagation of a Linear FM Pulse Waveform to and from a Target” on page 9-3
“One-Way and Two-Way Propagation” on page 9-4
“Propagation from Stationary Radar to Moving Target” on page 9-6

Support for Modeling Propagation in Free Space

Propagation environments have significant effects on the amplitude, phase, and shape of propagating space-time wavefields. In some cases, you may want to simulate a system that propagates narrowband signals through free space. If so, you can use the `phased.FreeSpace` System object to model the range-dependent time delay, phase shift, Doppler shift, and gain effects.

Consider this object as a point-to-point propagation channel. By setting object properties, you can customize certain characteristics of the environment and the signals propagating through it, including:

- Propagation speed and sampling rate of the signal you are propagating
- Signal carrier frequency
- Whether the object models one-way or two-way propagation

Each time you call `step` on a `phased.FreeSpace` object, you specify not only the signal to propagate, but also the location and velocity of the signal origin and destination.

You can use `fsp1` to determine the free space path loss, in decibels, for a given distance and wavelength.

Free Space Path Loss in Decibels

Assume a transmitter is located at [1000; 250; 10] in the global coordinate system. Assume a target is located at [3000; 750; 20]. The transmitter operates at 1 GHz. Determine the free space path loss in decibels for a narrowband signal propagating to and from the target.

```
[tgtrng,~] = rangeangle([3000; 750; 20],[1000; 250; 10]);
% Multiply range by two for two-way propagation
tgtrng = 2*tgtrng;
% Determine the wavelength for 1 GHz
lambda = physconst('LightSpeed')/1e9;
L = fspl(tgtrng,lambda)
```

The free space path loss in decibels is approximately 105 dB. You can express this value as:

```
Loss = pow2db((4*pi*tgtrng/lambda)^2)
```

which is a direct implementation of the equation for free space path loss.

Propagation of a Linear FM Pulse Waveform to and from a Target

Construct a linear FM pulse waveform 50 ms in duration with a bandwidth of 100 kHz. Model the range-dependent time delay and amplitude loss incurred during two-way propagation. The pulse propagates between the transmitter located at [1000; 250; 10] and a target location of [3000; 750; 20].

```
hwav = phased.LinearFMWaveform('SweepBandwidth',1e5,...
    'PulseWidth',5e-5,'OutputFormat','Pulses',...
    'NumPulses',1,'SampleRate',1e6,'PRF',1e4);
wf = step(hwav);
hpath = phased.FreeSpace('SampleRate',1e6,...
    'TwoWayPropagation',true,'OperatingFrequency',1e9);
y = step(hpath,wf,[1000; 250; 10],[3000; 750; 20],...
    [0;0;0],[0;0;0]);
```

Plot the magnitude of the transmitted and received pulse to show the amplitude loss and time delay. Scale the time axis in microseconds.

```
t = unigrid(0,1/hwav.SampleRate,1/hwav.PRf,'[]');
```

```

subplot(2,1,1)
plot(t.*1e6,abs(wf)); title('Magnitude of Transmitted Pulse');
xlabel('Microseconds'); ylabel('Magnitude');
subplot(2,1,2);
plot(t.*1e6,abs(y)); title('Magnitude of Received Pulse');
xlabel('Microseconds'); ylabel('Magnitude');

```

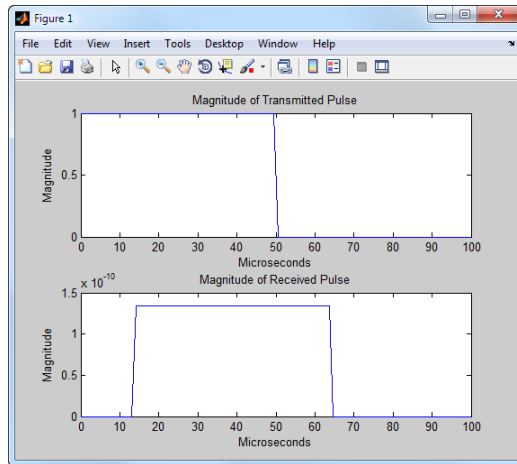

The delay in the received pulse is approximately 14 μs , which is exactly what you expect for a distance of 4.123 km at the speed of light.

One-Way and Two-Way Propagation

The `TwoWayPropagation` property of the `phased.FreeSpace` object enables you to use the `step` method for one- or two-way propagation. The following example demonstrates how to use this property for a single linear FM pulse propagated to and from a target. The sensor is a single isotropic radiating antenna operating at 1 GHz located at [1000; 250; 10]. The target is located at [3000; 750; 20] and has a nonfluctuating RCS of 1 square meter.

The following code constructs the required objects and calculates the range and angle from the antenna to the target.

```

hwav = phased.LinearFMWaveform('SweepBandwidth',1e5,...
    'PulseWidth',5e-5,'OutputFormat','Pulses',...
    'NumPulses',1,'SampleRate',1e6);

```

```

hant = phased.IsotropicAntennaElement(...
    'FrequencyRange',[500e6 1.5e9]);
htx = phased.Transmitter('PeakPower',1e3,'Gain',20);
hrad = phased.Radiator('Sensor',hant,'OperatingFrequency',1e9);
hpath = phased.FreeSpace('SampleRate',1e6,...
    'TwoWayPropagation',true,'OperatingFrequency',1e9);
htgt = phased.RadarTarget('MeanRCS',1,'Model','Nonfluctuating');
hcol = phased.Collector('Sensor',hant,'OperatingFrequency',1e9);
sensorpos = [3000; 750; 20];
tgtpos = [1000; 250; 10];
[tgtrng,tgtang] = rangeangle(sensorpos,tgtpos);

```

Because the `TwoWayPropagation` property is set to `true`, you call the `step` method for the `phased.FreeSpace` object only once. The following code calls the `step` after the pulse is radiated from the antenna and before the pulse is reflected from the target.

```

pulse = step(hwav); % Generate pulse
pulse = step(htx,pulse); % Transmit pulse
pulse = step(hrad,pulse,tgtang); % Radiate pulse
% Propagate pulse to and from target
pulse = step(hpath,pulse,sensorpos,tgtpos,[0;0;0],[0;0;0]);
pulse = step(htgt,pulse); % Reflect pulse
sig = step(hcol,pulse,tgtang); % Collect pulse

```

Alternatively, if you prefer to break up the two-way propagation into two separate calls to the `step` method, you can do so by setting the `TwoWayPropagation` property to `false`.

```

hpath = phased.FreeSpace('SampleRate',1e9,...
    'TwoWayPropagation',false,'OperatingFrequency',1e6);

pulse = step(hwav); % Generate pulse
pulse = step(htx,pulse); % Transmit pulse
pulse = step(hrad,pulse,tgtang); % Radiate pulse
% Propagate pulse from the antenna to the target
pulse = step(hpath,pulse,sensorpos,tgtpos,[0;0;0],[0;0;0]);
pulse = step(htgt,pulse); % Reflect pulse
% Propagate pulse from the target to the antenna
pulse = step(hpath,pulse,tgtpos,sensorpos,[0;0;0],[0;0;0]);
sig = step(hcol,pulse,tgtang); % Collect pulse

```

Propagation from Stationary Radar to Moving Target

This example shows how to propagate a signal in free space from a stationary radar to a moving target.

Define the signal's sample rate, propagation speed, and carrier frequency. Define the signal as a sinusoid of frequency 150 Hz.

```
fs = 1000;  
c = 1500;  
fc = 300e3;  
N = 1024;  
t = (0:N-1)'/fs;  
x = exp(1i*2*pi*150*t);
```

Assume the target is approaching the radar at 0.5 m/s, and the radar is stationary. Find the Doppler shift that corresponds to this relative speed.

```
v = 0.5;  
dop = speed2dop(v,c/fc)
```

```
dop =
```

```
100
```

Create a `phased.FreeSpace` object, and use it to propagate the signal from the radar to the target. Assume the radar is at (0, 0, 0) and the target is at (100, 0, 0).

```
hpath = phased.FreeSpace('SampleRate',fs,...  
    'PropagationSpeed',c,'OperatingFrequency',fc);  
origin_pos = [0;0;0]; dest_pos = [100;0;0];  
origin_vel = [0;0;0]; dest_vel = [-v;0;0];  
y = step(hpath,x,origin_pos,dest_pos,origin_vel,dest_vel);
```

Plot the spectrum of the transmitted signal. The peak at 150 Hz reflects the frequency of the signal.

```
figure;  
window = 64;  
ovlp = 32;  
[Pxx,F] = pwelch(x,window,ovlp,N,fs);
```

```

plot(F,10*log10(Pxx));
grid;
xlabel('Frequency (Hz)');
ylabel('Power/Frequency (dB/Hz)');
title('Transmitted Signal')

```

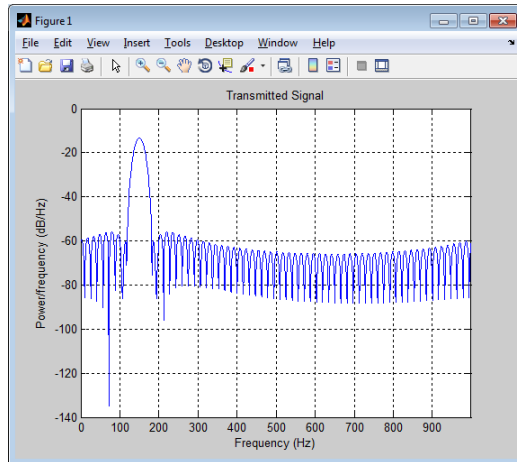

Plot the spectrum of the propagated signal. The peak at 250 Hz reflects the frequency of the signal plus the Doppler shift of 100 Hz.

```

figure;
window = 64;
ovlp = 32;
[Py,F] = pwelch(y,window,ovlp,N,fs);
plot(F,10*log10(Py));
grid;
xlabel('Frequency (Hz)');
ylabel('Power/Frequency (dB/Hz)');
title('Propagated Signal');

```

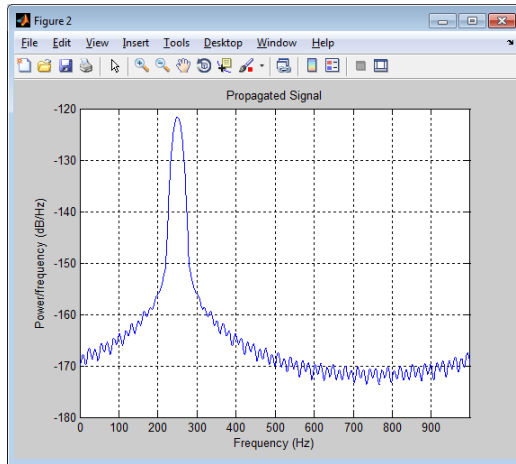

Radar Target

The phased.RadarTarget object models a reflected signal from a target with nonfluctuating or fluctuating radar cross section (RCS). This object has the following modifiable properties:

- MeanRCSSource — Source of the target's mean radar cross section
- MeanRCS — Target's mean RCS
- Model — Statistical model for the target's RCS
- PropagationSpeed — Signal propagation speed
- OperatingFrequency — Operating frequency
- SeedSource — Source of the seed for the random number generator to generate the target's random RCS values
- Seed — Seed for the random number generator

Create a radar target with a nonfluctuating RCS of 1 square meter and an operating frequency of 300 MHz. Specify a wave propagation speed equal to the speed of light.

```
hr = phased.RadarTarget('Model','nonfluctuating','MeanRCS',1,...
    'PropagationSpeed',physconst('LightSpeed'),...
    'OperatingFrequency',3e8);
```

The waveform incident on the target is scaled by the factor:

$$G = \sqrt{\frac{4\pi\sigma}{\lambda^2}}$$

Here, σ represents the target mean RCS, and λ is the wavelength of the operating frequency. Each element of the signal incident on the target is scaled by the preceding factor.

Create a target with a nonfluctuating RCS of 1 square meter. Set the operating frequency to 1 GHz. Set the signal incident on the target to be a vector of ones to demonstrate the gain factor.

```
hr = phased.RadarTarget('MeanRCS',1,'OperatingFrequency',1e9);
x = ones(10,1);
```

```
y = step(hr,x);
```

The output vector y is equal to $11.8245 \cdot \text{ones}(10,1)$. The amplitude scaling factor equals:

```
lambda = hr.PropagationSpeed/hr.OperatingFrequency;  
G = sqrt(4*pi*1/lambda^2)
```

The previous examples used nonfluctuating values for the target's RCS. This model is not valid in many scenarios. There are several cases where the RCS exhibits relatively small or large magnitude fluctuations. These fluctuations can occur rapidly on pulse-to-pulse, or more slowly, on scan-to-scan time scales:

- **Several small randomly distributed reflectors with no dominant reflector** — This target, at close range or when the radar uses pulse-to-pulse frequency agility, can exhibit large magnitude rapid (pulse-to-pulse) fluctuations in the RCS. That same complex reflector at long range with no frequency agility can exhibit large magnitude fluctuations in the RCS over a longer time scale (scan-to-scan).
- **Dominant reflector along with several small reflectors** — The reflectors in this target can exhibit small magnitude fluctuations on pulse-to-pulse or scan-to-scan time scales, subject to:
 - How rapidly the aspect changes
 - Whether the radar uses frequency agility

To account for significant fluctuations in the RCS, you need to use statistical models. The four *Swerling* models, described in the following table, are widely used to cover these kinds of fluctuating-RCS cases.

Swerling Case Number	Description
I	Scan-to-scan decorrelation. Rayleigh/exponential PDF — A number of randomly distributed scatterers with no dominant scatterer.
II	Pulse-to-pulse decorrelation. Rayleigh/exponential PDF — A number of randomly distributed scatterers with no dominant scatterer.
III	Scan-to-scan decorrelation — Chi-square PDF with 4 degrees of freedom. A number of scatterers with one scatterer dominant.
IV	Pulse-to-pulse decorrelation — Chi-square PDF with 4 degrees of freedom. A number of scatterers with one scatterer dominant.

You can simulate a Swerling target model by setting the `Model` property. Use the `step` method and set the `UPDATERCS` input argument to `true` or `false`. Setting `UPDATERCS` to `true` updates the RCS value according to the specified probability model each time you call `step`. If you set `UPDATERCS` to `false`, the previous RCS value is used.

Model Pulse Reflection from a Nonfluctuating Target

This example creates and transmits a linear FM waveform with a 1 GHz carrier frequency. The waveform is transmitted and collected by an isotropic antenna with a back-baffled response. The waveform propagates to and from a target with a nonfluctuating RCS of 1 square meter. The target is located approximately 1414 meters from the antenna at an angle of 45 degrees azimuth and 0 degrees elevation.

```
% Create objects and assign property values
% Isotropic antenna element
hant = phased.IsotropicAntennaElement('BackBaffled',true);
```

```
% Location of the antenna
harraypos = phased.Platform('InitialPosition',[0;0;0]);
% Location of the radar target
hrfpos = phased.Platform('InitialPosition',[1000; 1000; 0]);
% Linear FM waveform
hwav = phased.LinearFMWaveform('PulseWidth',100e-6);
% Transmitter
htx = phased.Transmitter('PeakPower',1e3,'Gain',40);
% Waveform radiator
hrad = phased.Radiator('OperatingFrequency',1e9, ...
    'Sensor',hant);
% Propagation environment to and from the RadarTarget
hspace = phased.FreeSpace('OperatingFrequency',1e9,...
    'TwoWayPropagation',true);
% Radar target
hr = phased.RadarTarget('MeanRCS',1,'OperatingFrequency',1e9);
% Collector
hc = phased.Collector('OperatingFrequency',1e9,...
    'Sensor',hant);

% Implement system
wf = step(hwav); % generate waveform
txwf = step(htx,wf); % transmit waveform
wfrad = step(hrad,txwf,[0 0]'); % radiate waveform
% propagate waveform to and from the RadarTarget
wfprop = step(hspace,wfrad,harraypos.InitialPosition,...
    hrfpos.InitialPosition,[0;0;0],[0;0;0]);
wfreflect = step(hr,wfprop); % reflect waveform
wfcol = step(hc,wfreflect,[45 0]'); % collect waveform
```

Clutter Modeling

In this section...

“Surface Clutter Overview” on page 9-13

“Approaches for Clutter Simulation or Analysis” on page 9-13

“Considerations for Setting Up a Constant Gamma Clutter Simulation” on page 9-14

“Related Examples” on page 9-15

Surface Clutter Overview

Surface clutter refers to reflections of a radar signal from land, sea, or the land-sea interface. When trying to detect or track targets moving on or above the surface, you must be able to distinguish between clutter and the targets of interest. For example, a ground moving target indicator (GMTI) radar application should detect targets on the ground while accounting for radar reflections from trees or houses.

If you are simulating a radar system, you might want to incorporate surface clutter into the simulation to ensure the system can overcome the effects of surface clutter. If you are analyzing the statistical performance of a radar system, you might want to incorporate clutter return distributions into the analysis.

Approaches for Clutter Simulation or Analysis

Phased Array System Toolbox software offers these tools to help you incorporate surface clutter into your simulation or analysis:

- `phased.ConstantGammaClutter`, a System object that simulates clutter returns using the constant gamma model
- Utility functions to help you implement your own clutter models:
 - `billingsleyicm`
 - `depressionang`
 - `effearthradius`

- grazingang
- horizonrange
- surfclutterrcs
- surfacegamma

Considerations for Setting Up a Constant Gamma Clutter Simulation

When you use `phased.ConstantGammaClutter`, you must configure the object for the situation you are simulating, and confirm that the assumptions the software makes are valid for your system.

Physical Configuration Properties

The `ConstantGammaClutter` object has properties that correspond to physical aspects of the situation you are modeling. These properties include:

- Propagation speed, sample rate, and pulse repetition frequency of the signal
- Operating frequency of the system
- Altitude, speed, and direction of the radar platform
- Depression angle of the broadside of the radar antenna array

Clutter-Related Properties

The object has properties that correspond to the clutter characteristics, location, and modeling fidelity. These properties include:

- Gamma parameter that depends on the terrain type and system's operating frequency.
- Azimuth coverage and maximum range for the clutter simulation.
- Azimuth span of each clutter patch. The software internally divides the clutter ring into a series of adjacent, nonoverlapping clutter patches.
- Clutter coherence time. This value indicates how frequently the software changes the set of random numbers in the clutter simulation.

In the simulation, you can use identical random numbers over a time interval or uncorrelated random numbers. Simulation behavior slightly

differs from reality, where a moving platform produces clutter returns that are correlated with each other over small time intervals.

Working with Samples or Pulses

The `ConstantGammaClutter` object has properties that let you obtain results in a convenient format. Using the `OutputFormat` property, you can choose to have the `step` method produce a signal that represents:

- A fixed number of pulses. You indicate the number of pulses using the `NumPulses` property of the object.
- A fixed number of samples. You indicate the number of samples using the `NumSamples` property of the object. Typically, you use the number of samples in one pulse. In staggered PRF applications, you might find this option more convenient because the `step` output always has the same matrix size.

Assumptions

The clutter simulation that `ConstantGammaClutter` provides is based on these assumptions:

- The radar system is monostatic.
- The propagation is in free space.
- The terrain is homogeneous.
- The clutter patch is stationary during the coherence time. *Coherence time* indicates how frequently the software changes the set of random numbers in the clutter simulation.
- The signal is narrowband. Thus, the spatial response can be approximated by a phase shift. Similarly, the Doppler shift can be approximated by a phase shift.
- The radar system maintains a constant height during simulation.
- The radar system maintains a constant speed during simulation.

Related Examples

- Ground Clutter Mitigation with Moving Target Indication (MTI) Radar

- Introduction to Space-Time Adaptive Processing
- “Example: DPCA Pulse Canceller for Clutter Rejection” on page 7-9
- “Example: Adaptive DPCA Pulse Canceller” on page 7-14
- “Example: Sample Matrix Inversion (SMI) Beamformer” on page 7-21

Barrage Jammer

In this section...

“Support for Modeling Barrage Jammer” on page 9-17

“Model Real and Imaginary Parts of Barrage Jammer Output” on page 9-17

“Model Effect of Barrage Jammer on Target Echo” on page 9-18

Support for Modeling Barrage Jammer

The `phased.BarrageJammer` object models a broadband jammer. The output of `phased.BarrageJammer` is a complex white Gaussian noise sequence. The modifiable properties of the barrage jammer are:

- `ERP` — Effective radiated power in watts
- `SamplesPerFrameSource` — Source of number of samples per frame
- `SamplesPerFrame` — Number of samples per frame
- `SeedSource` — Source of seed for random number generator
- `Seed` — Seed for random number generator

The real and imaginary parts of the complex white Gaussian noise sequence each have variance equal to 1/2 the effective radiated power in watts. Denote the effective radiated power in watts by P . The barrage jammer output is:

$$w[n] = \sqrt{\frac{P}{2}}x[n] + j\sqrt{\frac{P}{2}}y[n]$$

In this equation, $x[n]$ and $y[n]$ are mutually uncorrelated sequences of Gaussian random variables with zero mean and unit variance.

Model Real and Imaginary Parts of Barrage Jammer Output

Create a barrage jammer with the default effective radiated power of 5000 W. Generate 500 samples per frame.

```
hjam = phased.BarrageJammer('ERP',5e3,'SamplesPerFrame',500);
y = step(hjam);
```

```

subplot(2,1,1)
hist(real(y)); title('Histogram of Real Part');
subplot(2,1,2)
hist(imag(y)); title('Histogram of Imaginary Part');
xlabel('Watts');

```

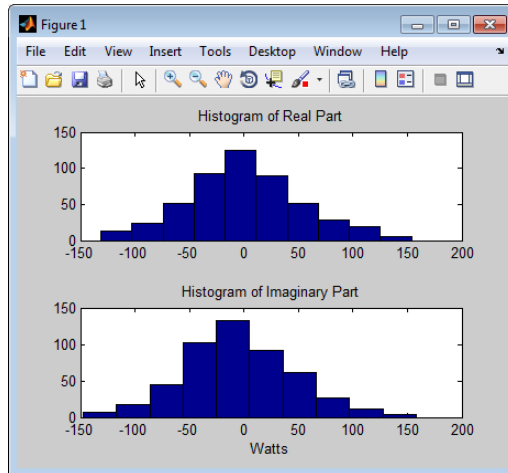

Model Effect of Barrage Jammer on Target Echo

This example demonstrates how to simulate the effect of a barrage jammer on a target echo.

First, create the required objects. You need an array, a transmitter, a radiator, a target, a jammer, a collector, and a receiver. Additionally, you need to define two propagation paths: one from the array to the target and back, and the other path from the jammer to the array.

```

hula = phased.ULA(4);
Fs = 1e6;
fc = 1e9;
hwav = phased.RectangularWaveform('PulseWidth',100e-6,...
    'PRF',1e3,'NumPulses',5,'SampleRate',Fs);
htx = phased.Transmitter('PeakPower',1e4,'Gain',20,...
    'InUseOutputPort',true);
hrad = phased.Radiator('Sensor',hula,'OperatingFrequency',fc);

```



```

hjammer = phased.BarrageJammer('ERP',1000,...
    'SamplesPerFrame',hwav.NumPulses*hwav.SampleRate/hwav.PRF);
htarget = phased.RadarTarget('Model','Nonfluctuating',...
    'MeanRCS',1,'OperatingFrequency',fc);
htargetpath = phased.FreeSpace('TwoWayPropagation',true,...
    'SampleRate',Fs,'OperatingFrequency',fc);
hjammerpath = phased.FreeSpace('TwoWayPropagation',false,...
    'SampleRate',Fs,'OperatingFrequency',fc);
hcollector = phased.Collector('Sensor',hula,...
    'OperatingFrequency',fc);
hrc = phased.ReceiverPreamp('EnableInputPort',true);

```

Assume that the array, target, and jammer are stationary. The array is located at the global origin, $[0;0;0]$. The target is located at $[1000;500;0]$, and the jammer is located at $[2000;2000;100]$. Determine the directions from the array to the target and jammer.

```

targetloc = [1000; 500; 0];
jammerloc = [2000; 2000; 100];
[~,tgtang] = rangeangle(targetloc);
[~,jamang] = rangeangle(jammerloc);

```

Finally, transmit the rectangular pulse waveform to the target, reflect it off the target, and collect the echo at the array. Simultaneously, the jammer transmits a jamming signal toward the array. The jamming signal and echo are mixed at the receiver.

```

% Generate waveform
wf = step(hwav);
% Transmit waveform
[wf,txstatus] = step(htx,wf);
% Radiate pulse toward the target
wf = step(hrad,wf,tgtang);
% Propagate pulse toward the target
wf = step(htargetpath,wf,[0;0;0],targetloc,[0;0;0],[0;0;0]);
% Reflect it off the target
wf = step(htarget,wf);
% Collect the echo
wf = step(hcollector,wf,tgtang);

% Generate the jamming signal

```

```

jamsig = step(hjammer);
% Propagate the jamming signal to the array
jamsig = step(hjammerpath,jamsig,jammerloc,[0;0;0],...
    [0;0;0],[0;0;0]);
% Collect the jamming signal
jamsig = step(hcollector,jamsig,jamang);

% Receive target echo alone and target echo + jamming signal
pulsewave = step(hrc, wf,~txstatus);
pulsewave_jamsig = step(hrc,wf+jamsig,~txstatus);

```

Plot the result, and compare it with received waveform with and without jamming.

```

subplot(2,1,1);
t = unigrid(0,1/Fs,size(pulsewave,1)*1/Fs,['']);
plot(t,abs(pulsewave(:,1)));
title('Magnitudes of Pulse Waveform Without Jamming--Element 1')
ylabel('Magnitude');
subplot(2,1,2);
plot(t,abs(pulsewave_jamsig(:,1)));
title('Magnitudes of Pulse Waveform with Jamming--Element 1')
xlabel('Seconds'); ylabel('Magnitude');

```

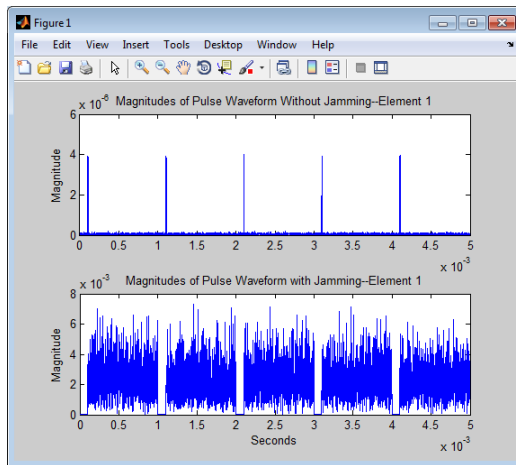

Coordinate Systems and Motion Modeling

- “Rectangular Coordinates” on page 10-2
- “Spherical Coordinates” on page 10-16
- “Global and Local Coordinate Systems” on page 10-23
- “Motion Modeling in Phased Array Systems” on page 10-30
- “Doppler Shift and Pulse-Doppler Processing” on page 10-35

Rectangular Coordinates

In this section...

“Definitions of Coordinates” on page 10-2

“Notation for Vectors and Points” on page 10-3

“Orthogonal Basis and Euclidean Norm” on page 10-3

“Orientation of Coordinate Axes” on page 10-4

“Rotations and Rotation Matrices” on page 10-7

Definitions of Coordinates

Construct a rectangular, or Cartesian, coordinate system for three-dimensional space by specifying three mutually orthogonal coordinate axes. The following figure shows one possible specification of the coordinate axes.

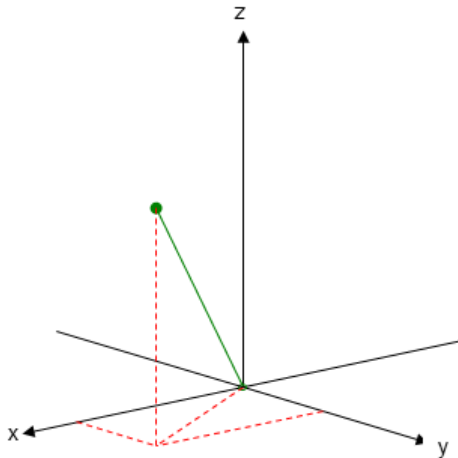

Rectangular coordinates specify a position in space in a given coordinate system as an ordered 3-tuple of real numbers, (x,y,z) , with respect to the origin $(0,0,0)$. Considerations for choosing the origin are discussed in “Global and Local Coordinate Systems” on page 10-23.

You can view the 3-tuple as a point in space, or equivalently as a vector in three-dimensional Euclidean space. Viewed as a vector space, the coordinate axes are basis vectors and the vector gives the direction to a point in space from the origin. Every vector in space is uniquely determined by a linear combination of the basis vectors. The most common set of basis vectors for three-dimensional Euclidean space are the standard unit basis vectors:

$$\{[1 \ 0 \ 0],[0 \ 1 \ 0],[0 \ 0 \ 1]\}$$

Notation for Vectors and Points

In Phased Array System Toolbox software, you specify both coordinate axes and points as column vectors.

Note In this software, all coordinate vectors are column vectors. For convenience, the documentation represents column vectors in the format $[x \ y \ z]$ without transpose notation.

Both the vector notation $[x \ y \ z]$ and point notation (x,y,z) are used interchangeably. The interpretation of the column vector as a vector or point depends on the context. If the column vector specifies the axes of a coordinate system or direction, it is a vector. If the column vector specifies coordinates, it is a point.

Orthogonal Basis and Euclidean Norm

Any three linearly independent vectors define a basis for three-dimensional space. However, this software assumes that the basis vectors you use are orthogonal.

The standard distance measure in space is the l^2 norm, or Euclidean norm. The Euclidean norm of a vector $[x \ y \ z]$ is defined by:

$$\sqrt{x^2 + y^2 + z^2}$$

The Euclidean norm gives the length of the vector measured from the origin as the hypotenuse of a right triangle. The distance between two vectors $[x_0 \ y_0 \ z_0]$ and $[x_1 \ y_1 \ z_1]$ is:

$$\sqrt{(x_0 - x_1)^2 + (y_0 - y_1)^2 + (z_0 - z_1)^2}$$

Orientation of Coordinate Axes

Given an orthonormal set of basis vectors representing the coordinate axes, there are multiple ways to orient the axes. The following figure illustrates one such orientation, called a *right-handed* coordinate system. The arrows on the coordinate axes indicate the positive directions.

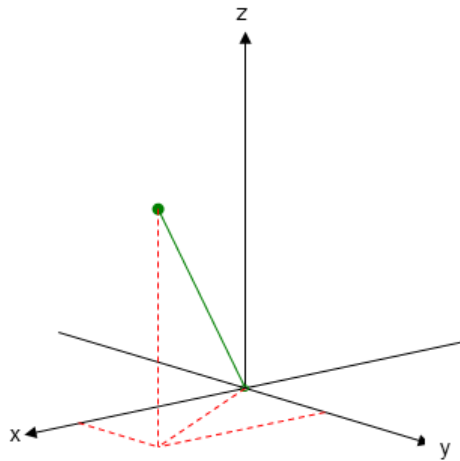

If you take your right hand and point it along the positive x -axis with your palm facing the positive y -axis and extend your thumb, your thumb indicates the positive direction of the z -axis.

Phase Center of Array

For some array geometries, it is convenient to define the origin as the phase center of the array. For example, create a default uniform linear array (ULA) and query the element coordinates:

```
H = phased.ULA('NumElements',2,'ElementSpacing',0.5)
```

```
getElementPosition(H)
```

The following figure illustrates the default ULA with array elements located at $(0, -0.25, 0)$ and $(0, 0.25, 0)$.

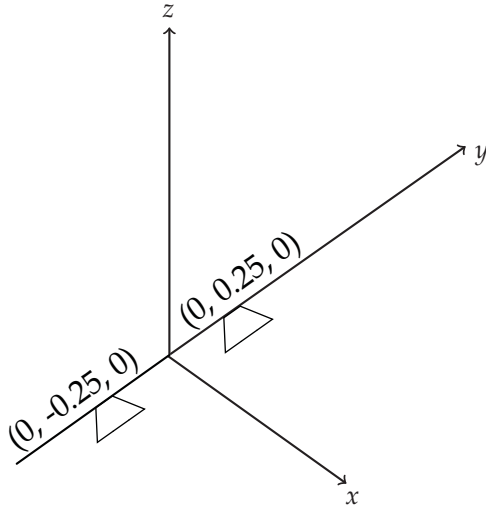

The next example creates a uniform rectangular array (URA) with four elements:

```
H = phased.URA('Size',[2 2],'ElementSpacing',[0.5 0.5])
ElementLocs = getElementPosition(H)
```

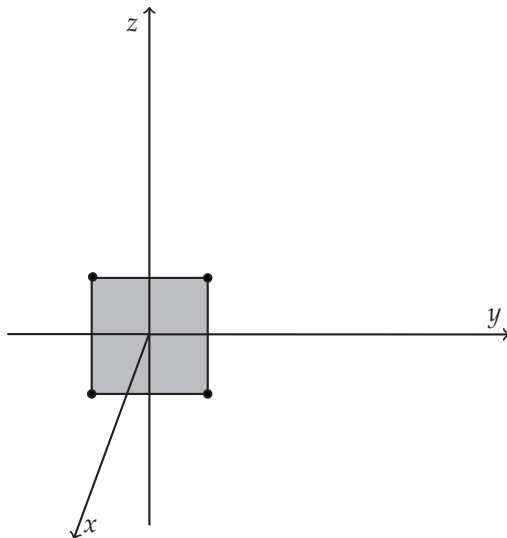

Boresight Direction

The direction that an antenna is facing when transmitting and receiving a signal is referred to as the *boresight*, or *look* direction. The convention in this software for specifying coordinate axes designates the positive x -axis as the boresight direction. The following figure shows a right-handed coordinate system with the positive x -axis oriented along the sensor boresight direction.

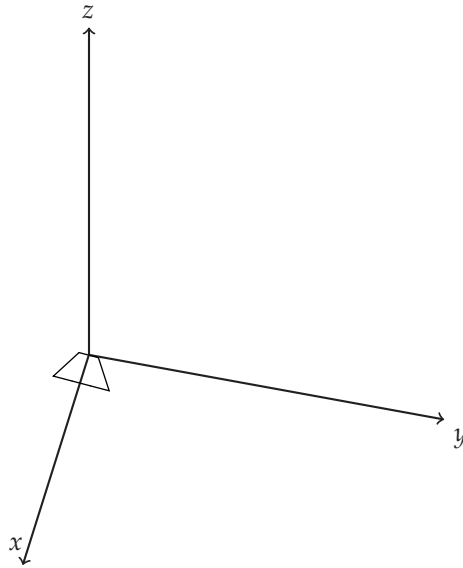

Common Boresight Direction

In ULAs and URAs, the boresight directions of all the array elements are equal. In the case of the ULA, the y -axis is aligned with the array element apertures. This alignment is referred to as the *array axis*. The array elements have a common boresight direction, which the toolbox designates as the x -axis. The x -axis is orthogonal, or *normal*, to the array axis.

In the case of the URA, the array element apertures lie in the yz plane and also exhibit a common boresight direction. The x -axis is normal to the plane containing the array elements. This alignment illustrates the software convention that the x -axis is the direction normal to the array.

In the case of conformal arrays, the elements do not share a common boresight direction and the direction normal to each element is a property of the individual array elements.

Rotations and Rotation Matrices

In transforming vectors in three-dimensional space, rotation matrices are often encountered. Rotation matrices are used in two senses: they can be

used to rotate a vector into a new position or they can be used to rotate a coordinate basis (or coordinate system) into a new one. In this case, the vector is left alone but its components in the new basis will be different from those in the original basis. In Euclidean space, there are three basic rotations: one each around the x, y and z axes. Each rotation is specified by an angle of rotation. The rotation angle is defined to be positive for a rotation that is counterclockwise when viewed by an observer looking along the rotation axis towards the origin. Any arbitrary rotation can be composed of a combination of these three (*Euler's rotation theorem*). For example, one can rotated a vector using a sequence of three rotations: $\mathbf{v}' = \mathbf{A}\mathbf{v} = \mathbf{R}_z(\gamma)\mathbf{R}_y(\beta)\mathbf{R}_x(\alpha)\mathbf{v}$.

The rotation matrices that rotate a vector around the x, y, and z-axes are given by:

- Counterclockwise rotation around x-axis

$$\mathbf{R}_x(\alpha) = \begin{bmatrix} 1 & 0 & 0 \\ 0 & \cos\alpha & -\sin\alpha \\ 0 & \sin\alpha & \cos\alpha \end{bmatrix}$$

- Counterclockwise rotation around y-axis

$$\mathbf{R}_y(\beta) = \begin{bmatrix} \cos\beta & 0 & \sin\beta \\ 0 & 1 & 0 \\ -\sin\beta & 0 & \cos\beta \end{bmatrix}$$

- Counterclockwise rotation around z-axis

$$\mathbf{R}_z(\gamma) = \begin{bmatrix} \cos\gamma & -\sin\gamma & 0 \\ \sin\gamma & \cos\gamma & 0 \\ 0 & 0 & 1 \end{bmatrix}$$

The following three figures show what positive rotations look like for each rotation axis:

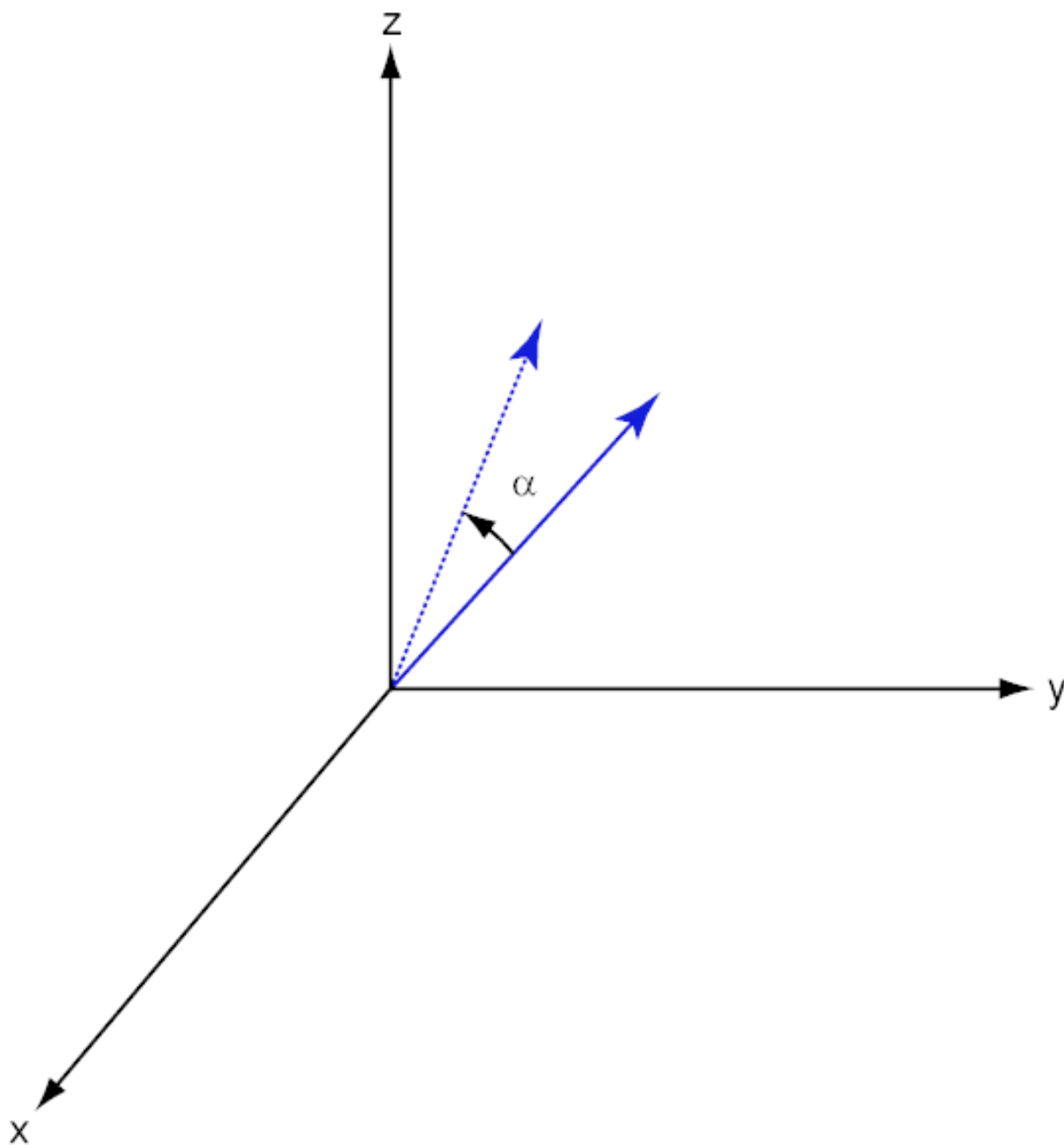

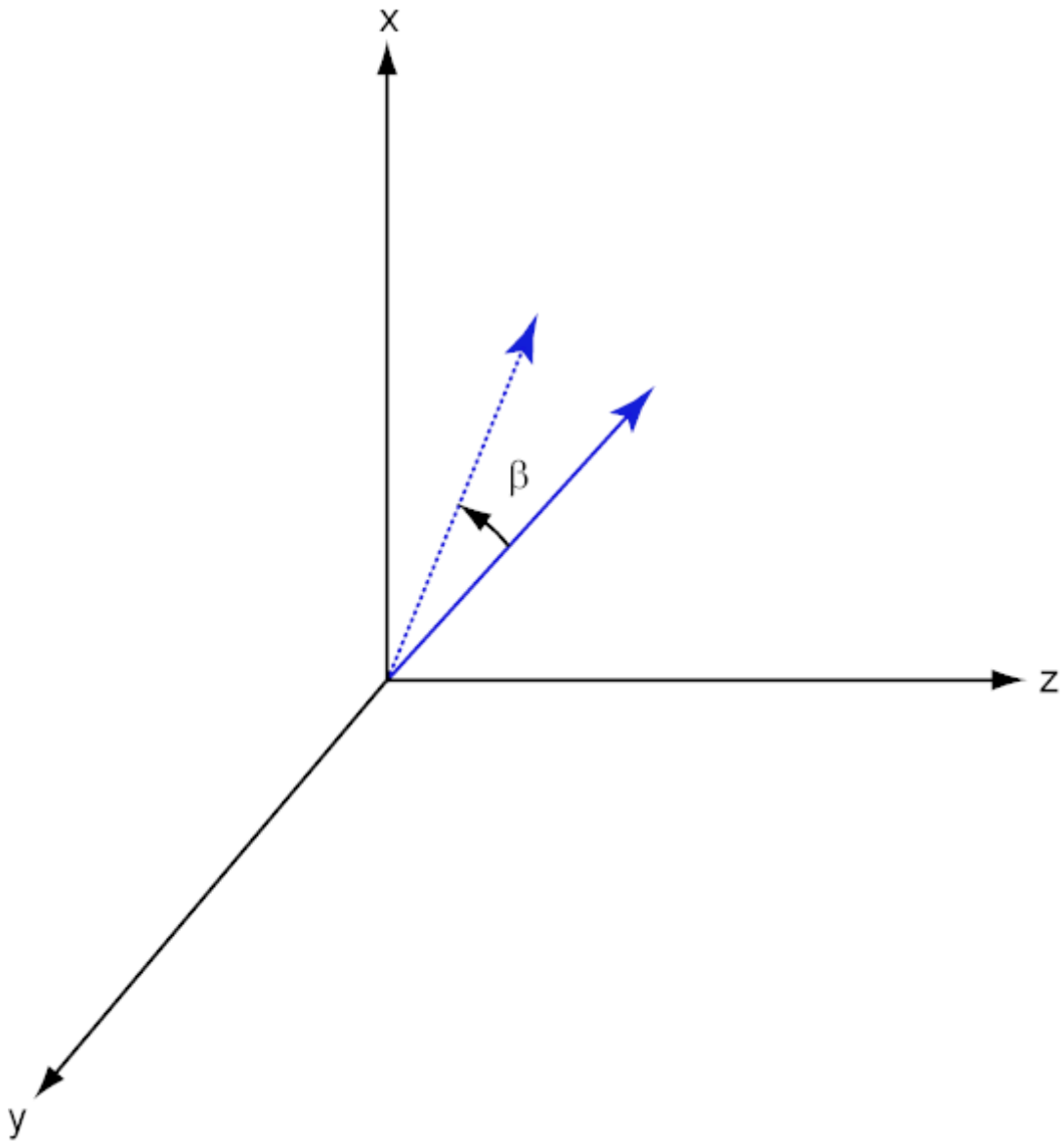

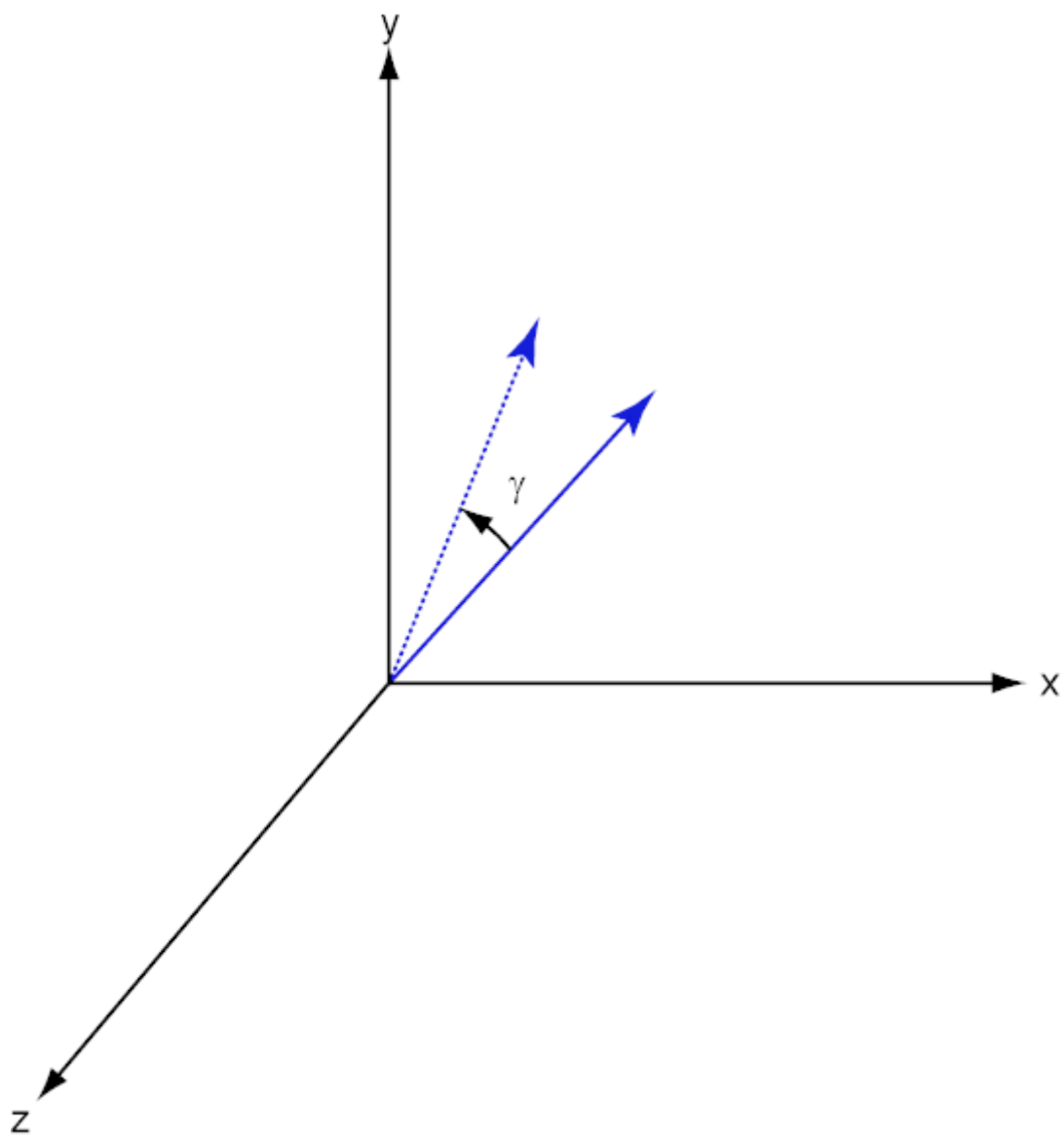

For any rotation, there is an inverse rotation satisfying $A^{-1}A = 1$. For example, the inverse of the x-axis rotation matrix is obtained by changing the sign of the angle:

$$R_x^{-1}(\alpha) = R_x(-\alpha) = \begin{bmatrix} 1 & 0 & 0 \\ 0 & \cos \alpha & \sin \alpha \\ 0 & -\sin \alpha & \cos \alpha \end{bmatrix} = R_x'(\alpha)$$

This example illustrates a basic property: the inverse rotation matrix equals the transpose of the original. Rotation matrices satisfy $A'A = 1$, and consequently $\det(A) = 1$. Under rotations, vector lengths are preserved as well as the angles between vectors.

We can think of rotations in another way. Consider the original set of basis vectors, $\mathbf{i}, \mathbf{j}, \mathbf{k}$, and rotate them all using the rotation matrix A . This produces a new set of basis vectors $\mathbf{i}', \mathbf{j}', \mathbf{k}'$ related to the original by:

$$\begin{aligned} \mathbf{i}' &= A\mathbf{i} \\ \mathbf{j}' &= A\mathbf{j} \\ \mathbf{k}' &= A\mathbf{k} \end{aligned}$$

The new basis vectors can be written as linear combinations of the old ones and involve the transpose:

$$\begin{bmatrix} \mathbf{i}' \\ \mathbf{j}' \\ \mathbf{k}' \end{bmatrix} = A' \begin{bmatrix} \mathbf{i} \\ \mathbf{j} \\ \mathbf{k} \end{bmatrix}$$

Now any vector can be written as a linear combination of either set of basis vectors:

$$\mathbf{v} = v_x\mathbf{i} + v_y\mathbf{j} + v_z\mathbf{k} = v'_x\mathbf{i}' + v'_y\mathbf{j}' + v'_z\mathbf{k}'$$

Using some algebraic manipulation, one can derive the transformation of components for a fixed vector when the basis (or coordinate system) rotates

$$\begin{bmatrix} v'_x \\ v'_y \\ v'_z \end{bmatrix} = A^{-1} \begin{bmatrix} v_x \\ v_y \\ v_z \end{bmatrix} = A' \begin{bmatrix} v_x \\ v_y \\ v_z \end{bmatrix}$$

Thus the change in components of a vector when the coordinate system rotates involves the transpose of the rotation matrix. The next figure illustrates how a vector stays fixed as the coordinate system rotates around the x-axis. The figure after shows how this can be interpreted as a rotation *of the vector* in the opposite direction.

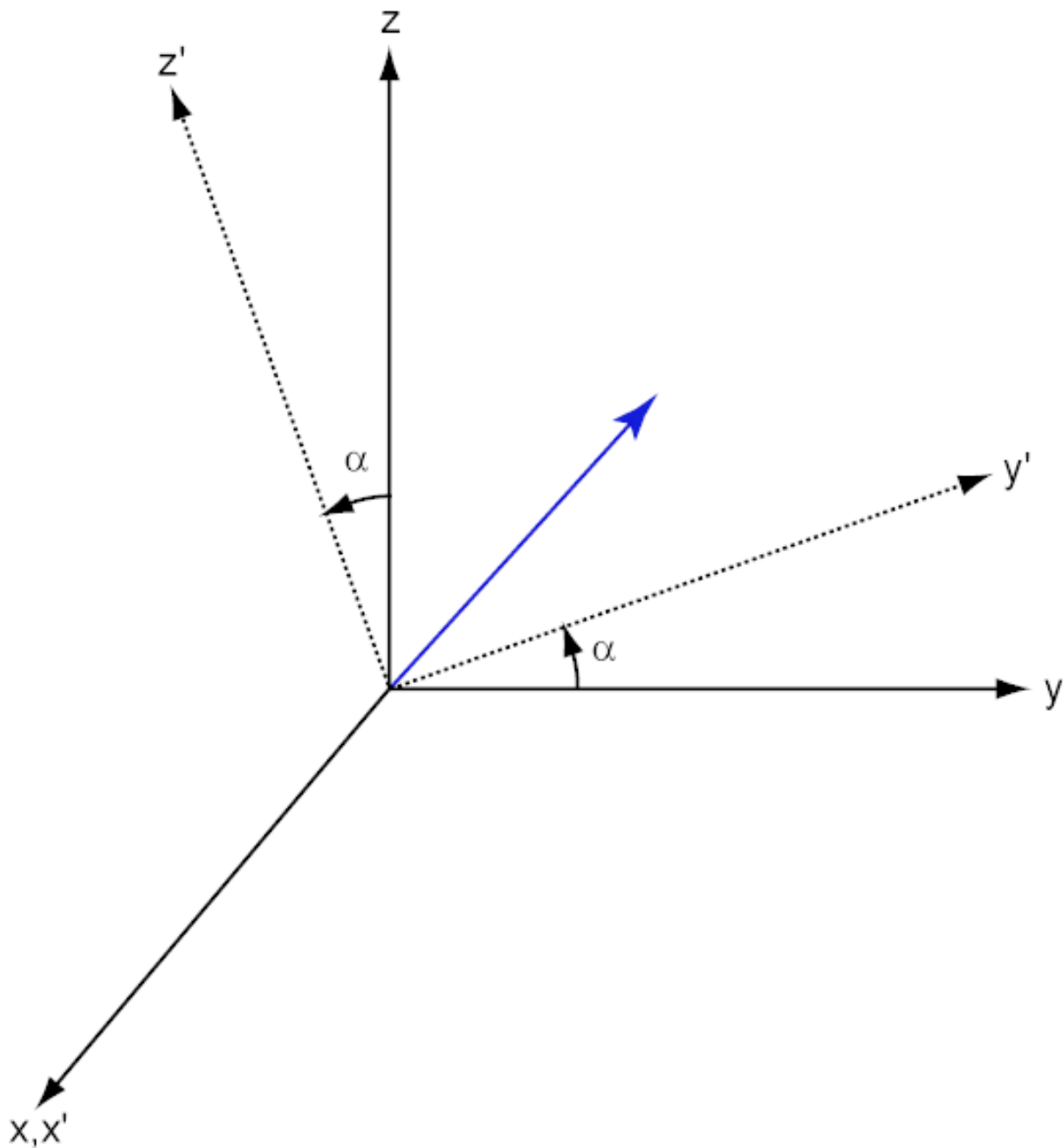

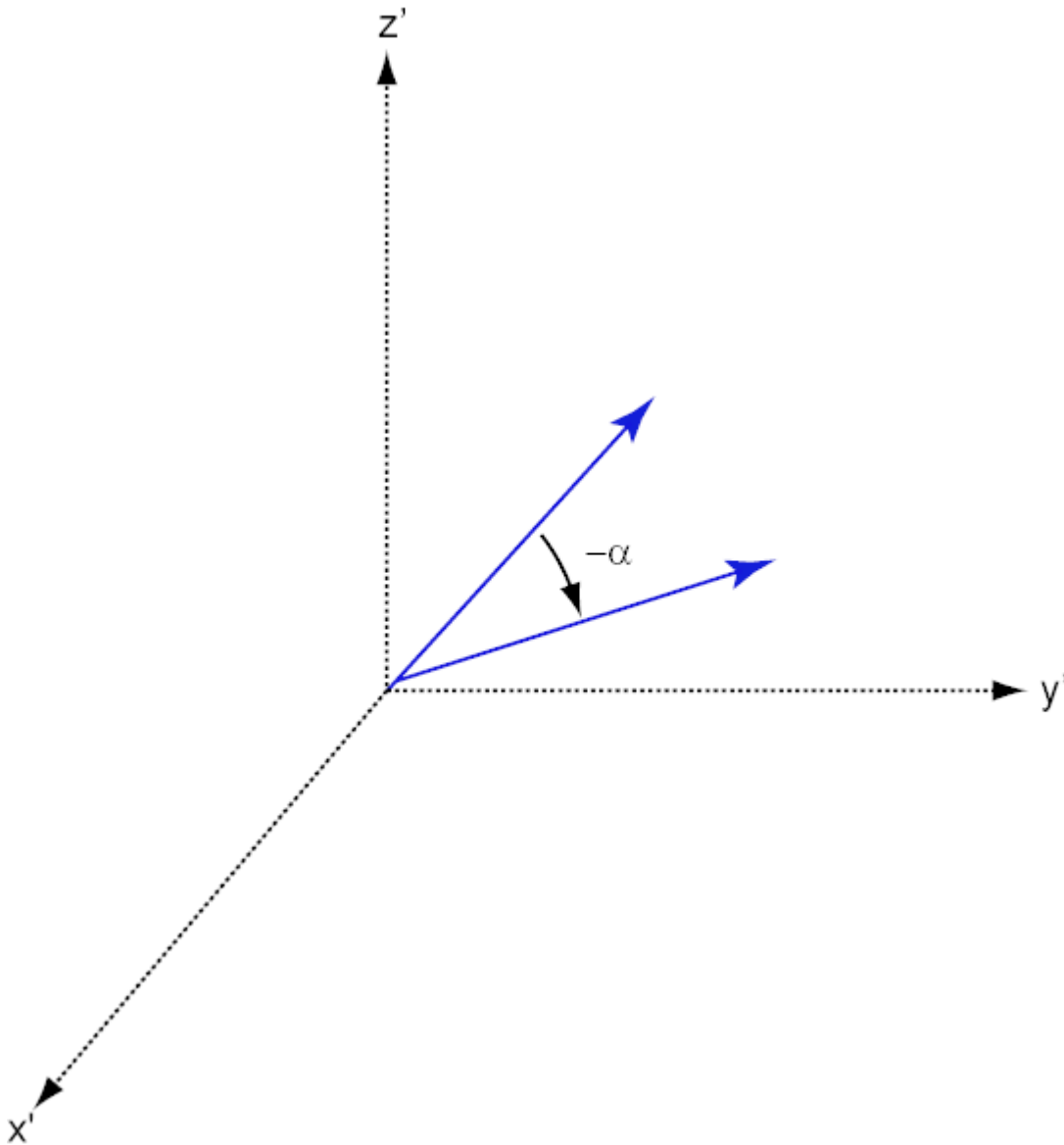
**Concepts**

- “Global and Local Coordinate Systems” on page 10-23

Spherical Coordinates

In this section...

“Support for Spherical Coordinates” on page 10-16

“Azimuth and Elevation Angles” on page 10-16

“Phi and Theta Angles” on page 10-17

“U and V Coordinates” on page 10-18

“Conversion Between Rectangular and Spherical Coordinates” on page 10-19

“Broadside Angle” on page 10-20

Support for Spherical Coordinates

Spherical coordinates describe a vector or point in space with a distance and two angles. The distance, R , is the usual Euclidean norm. There are multiple conventions regarding the specification of the two angles. They include:

- Azimuth and elevation angles
- Phi and theta angles
- u and v coordinates

Phased Array System Toolbox software natively supports the azimuth/elevation representation. The software also provides functions for converting between the azimuth/elevation representation and the other representations. See “Phi and Theta Angles” on page 10-17 and “U and V Coordinates” on page 10-18.

Azimuth and Elevation Angles

In Phased Array System Toolbox software, the predominant convention for spherical coordinates is as follows:

- Use the azimuth angle, az , and the elevation angle, el , to define the location of a point on the unit sphere.
- Specify all angles in degrees.

- List coordinates in the sequence (az, el, R) .

The *azimuth angle* is the angle from the positive x -axis toward the positive y -axis, to the vector's orthogonal projection onto the xy plane. The azimuth angle is between -180 and 180 degrees. The *elevation angle* is the angle from the vector's orthogonal projection onto the xy plane toward the positive z -axis, to the vector. The elevation angle is between -90 and 90 degrees. These definitions assume the boresight direction is the positive x -axis.

Note The elevation angle is sometimes defined in the literature as the angle a vector makes with the positive z -axis. The MATLAB and Phased Array System Toolbox products do not use this definition.

This figure illustrates the azimuth angle and elevation angle for a vector that appears as a green solid line. The coordinate system is relative to the center of a uniform linear array, whose elements appear as blue circles.

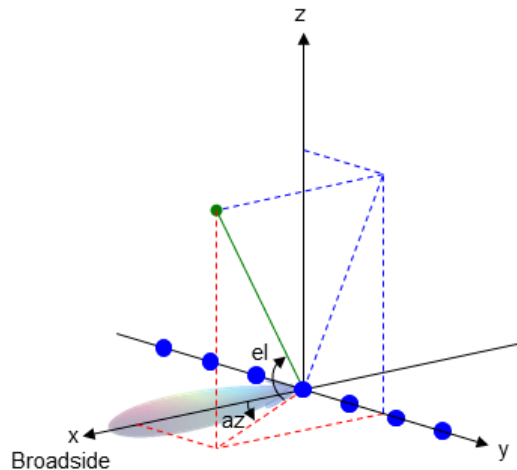

Phi and Theta Angles

As an alternative to azimuth and elevation angles, you can use angles denoted by ϕ and θ to express the location of a point on the unit sphere. To convert the ϕ/θ representation to and from the corresponding azimuth/elevation

representation, use coordinate conversion functions, `phitheta2azel` and `azel2phitheta`.

The φ angle is the angle from the positive y -axis toward the positive z -axis, to the vector's orthogonal projection onto the yz plane. The φ angle is between 0 and 360 degrees. The θ angle is the angle from the x -axis toward the yz plane, to the vector itself. The θ angle is between 0 and 180 degrees.

The figure illustrates φ and θ for a vector that appears as a green solid line. The coordinate system is relative to the center of a uniform linear array, whose elements appear as blue circles.

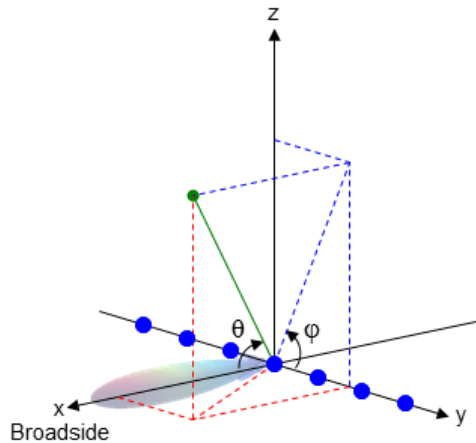

U and V Coordinates

In radar applications, it is often useful to parameterize the hemisphere $x \geq 0$ using coordinates denoted by u and v .

- To convert the φ/θ representation to and from the corresponding u/v representation, use coordinate conversion functions `phitheta2uv` and `uv2phitheta`.
- To convert the azimuth/elevation representation to and from the corresponding u/v representation, use coordinate conversion functions `azel2uv` and `uv2azel`.

You can define u and v in terms of φ and θ :

$$u = \sin(\theta) \cos(\varphi)$$

$$v = \sin(\theta) \sin(\varphi)$$

In these expressions, φ and θ are the phi and theta angles, respectively.

The values of u and v satisfy these inequalities:

$$-1 \leq u \leq 1$$

$$-1 \leq v \leq 1$$

$$u^2 + v^2 \leq 1$$

Conversion Between Rectangular and Spherical Coordinates

The following equations define the relationships between rectangular coordinates and the (az,el,R) representation used in Phased Array System Toolbox software.

To convert rectangular coordinates to (az,el,R) :

$$R = \sqrt{x^2 + y^2 + z^2}$$

$$az = \tan^{-1}(y / x)$$

$$el = \tan^{-1}(z / \sqrt{x^2 + y^2})$$

To convert (az,el,R) to rectangular coordinates:

$$x = R \cos(el) \cos(az)$$

$$y = R \cos(el) \sin(az)$$

$$z = R \sin(el)$$

When specifying a target's location with respect to a phased array, it is common to refer to its distance and direction from the array. The distance

from the array corresponds to R in spherical coordinates. The direction corresponds to the azimuth and elevation angles.

Tip To convert between rectangular coordinates and (az, el, R) , use the MATLAB functions `cart2sph` and `sph2cart`. These functions specify angles in radians. To convert between degrees and radians, use `degtorad` and `radtodeg`.

Broadside Angle

The special case of the uniform linear arrays (ULA) uses the concept of the *broadside angle*. The broadside angle is the angle measured from array normal direction projected onto the plane determined by the signal incident direction and the array axis to the signal incident direction. Broadside angles assume values in the interval $[-90, 90]$ degrees. The following figure illustrates the definition of the broadside angle.

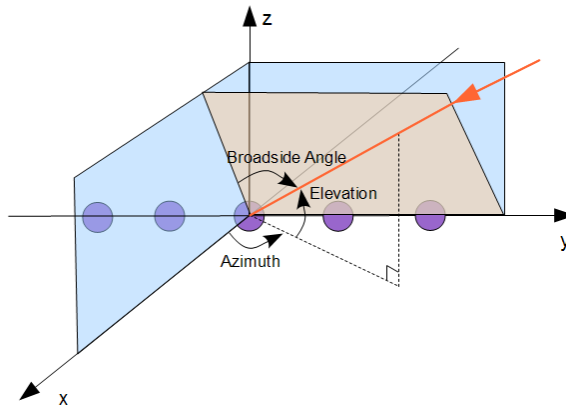

The shaded gray area in the figure is the plane determined by the signal incident direction and the array axis. The broadside angle is positive when measured toward the positive direction of the array axis. A number of algorithms for ULAs use the broadside angle instead of the azimuth and elevation angles. The algorithms do so because the broadside angle more accurately describes the ability to discern direction of arrival with this geometry.

Phased Array System Toolbox software provides functions `az2broadside` and `broadside2az` for converting between azimuth and broadside angles. The following equation determines the broadside angle, β , from the azimuth and elevation angles, az and el :

$$\beta = \sin^{-1}(\sin(az)\cos(el))$$

Expressing the broadside angle in terms of the azimuth and elevation angles reveals a number of important characteristics, including:

- For an elevation angle of zero degrees, the broadside angle is equal to the azimuth angle.
- Elevation angles equally above and below the xy plane result in identical broadside angles.

The following figure depicts a ULA with elements spaced d meters apart. The ULA is illuminated by a plane wave emitted from a point source in the far field. For convenience, the elevation angle is zero degrees. The plane determined by the signal incident direction and the array axis is the xy plane. The broadside angle reduces to the azimuth angle.

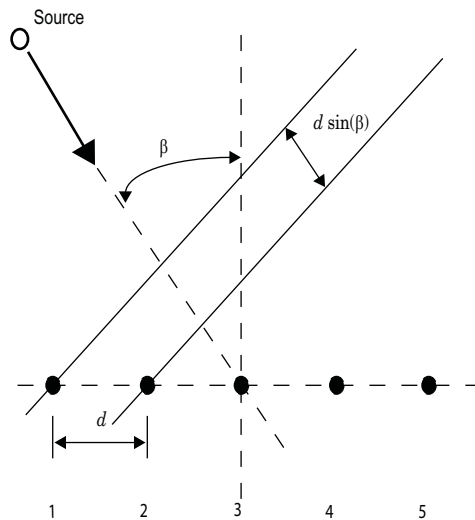

Because of the angle of arrival, the array elements are not simultaneously illuminated by the plane wave. The additional distance the incident wave travels between array elements is $d \sin(\beta)$ where d is the distance between array elements. Therefore, the constant time delay between array elements is:

$$\tau = \frac{d \sin(\beta)}{c},$$

where c is the speed of the wave.

For broadside angles of ± 90 degrees, the plane wave is incident on the array along the array axis and the time delay between sensors reduces to $\pm d/c$. For a broadside angle of 0 degrees, the plane wave illuminates all elements of the ULA simultaneously and the time delay between elements is zero.

The following examples show the use of the utility functions `az2broadside` and `broadside2az`:

A target is located at an azimuth angle of 45 degrees and elevation angle of 60 degrees relative to a ULA. Determine the corresponding broadside angle:

```
bsang = az2broadside(45,60)
% approximately 21 degrees
```

Calculate the azimuth corresponding to a broadside angle of 45 degrees and an elevation of 20 degrees:

```
az = broadside2az(45,20)
% approximately 49 degrees
```

Global and Local Coordinate Systems

In this section...
“Global Coordinate System” on page 10-23
“Local Coordinate System” on page 10-25
“Converting Between Global and Local Coordinate Systems” on page 10-28

Global Coordinate System

As the word *global* indicates, the global coordinate system describes the entire environment that you want to model. Within this global coordinate system, you can have several phased array systems, both stationary and mobile. You can also have a number of stationary and mobile targets. Additionally, there are usually stationary and mobile environmental features that produce spurious signals you want to ignore as well as stationary and mobile sources that are actively attempting to interfere with your phased arrays (jammers).

To extract useful information from this environment, you often need to analyze data from multiple phased arrays over time. Each phased array senses the environment from its own *local* perspective. To put the information from each phased array into a global perspective, you must know the location of each array in the global coordinate system and the orientation of the array's coordinate axes.

In the following figure, the solid dark axes denote the coordinate axes of a global coordinate system. There are two phased arrays, Array 1, and Array 2. Each of the phased arrays defines its own coordinate system within the global system denoted by the dashed lines. A target is indicated by the black circle.

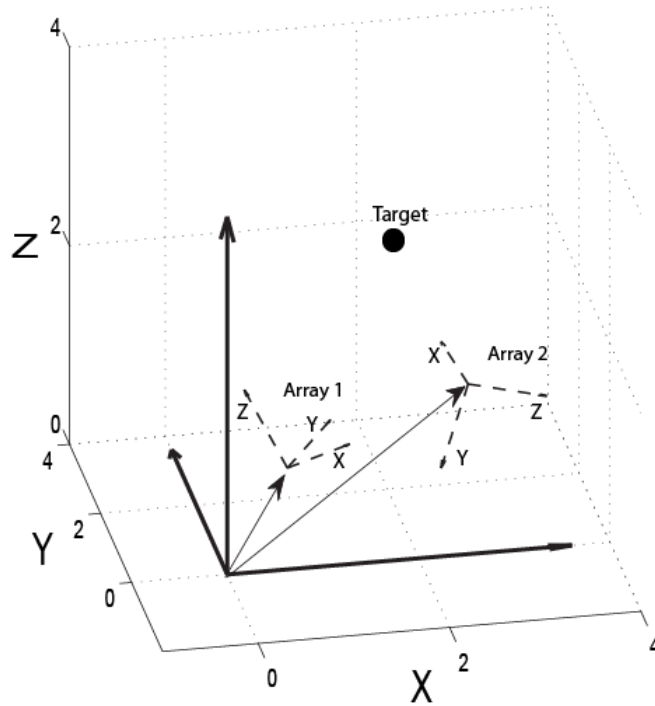

The two phased arrays detect the target and estimate target characteristics such as range and velocity. To translate information about the target derived from the two spatially-separated phased arrays, you must know the positions of the phased arrays and the orientation of their *local* coordinate axes with respect to the global coordinate system.

Note In specifying a global coordinate system, you can designate any point as the origin. The coordinate axes must be orthogonal.

Local Coordinate System

Local coordinate systems are defined by phased arrays located within the global coordinate system. The coordinate axes of a local coordinate system must be orthogonal, but they do not need to be parallel to the global coordinate axes. The local origin may be located anywhere in the global coordinate system and need not be stationary. For example, a vehicle-mounted phased array has its own local coordinate system, which moves within the global coordinate system.

You can specify target locations with respect to a local coordinate system in terms of *range* and *direction of arrival*. A target's range corresponds to R , the Euclidean distance in spherical coordinates. The direction of arrival corresponds to the azimuth and elevation angles. Phased Array System Toolbox software follows the MATLAB convention and lists spherical coordinates in the order: (az, el, R) .

The positions of all array elements in this software are in local coordinates. The following examples illustrate local coordinate systems for uniform linear, uniform rectangular, and conformal arrays.

Local Coordinate System for a Uniform Linear Array

For a uniform linear array (ULA), the origin of the local coordinate system is the phase center of the array. The positive x -axis is the direction normal to the array, and the elements of the array are located along the y -axis. The y -axis is referred to as the *array axis*. Define the axis normal to the array as the span of the vector $[1\ 0\ 0]$ and the array axis as the span of the vector $[0\ 1\ 0]$. The z -axis is the span of the vector $[0\ 0\ 1]$, which is the cross product of the two vectors: $[1\ 0\ 0]$ and $[0\ 1\ 0]$.

Construct a uniform linear array:

```
H = phased.ULA('NumElements',2,'ElementSpacing',0.5)
getElementPosition(H)
```

The following figure illustrates the default ULA in a local right-handed coordinate system:

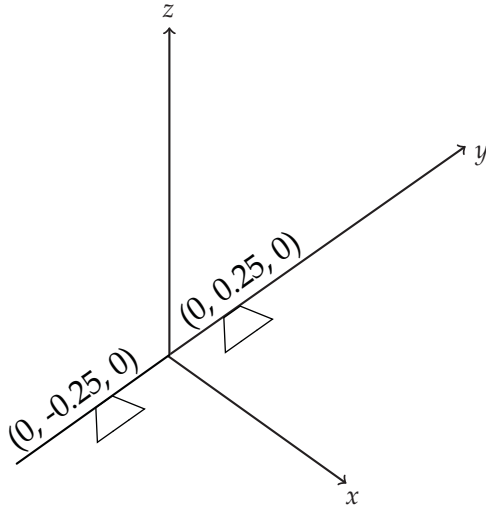

The elements are located 0.25 meters from the phase center of the array and the distance between the two elements is 0.5 meters.

Construct a ULA with eight elements spaced 0.25 meters apart:

```
H = phased.ULA('NumElements',8,'ElementSpacing',0.25)
% Invoke the getElementPosition method
% to see the local coordinates of the elements
getElementPosition(H)
```

Local Coordinate System of a Uniform Rectangular Array

In a uniform rectangular array (URA), the origin of the local coordinate system is the phase center of the array. The x -axis is the direction normal to the array. In the yz plane, the array elements have even row spacing and even column spacing.

Construct a URA:

```
H = phased.URA('Size',[2 2],'ElementSpacing',[0.5 0.5])
ElementLocs = getElementPosition(H)
```

The following figure illustrates the default URA:

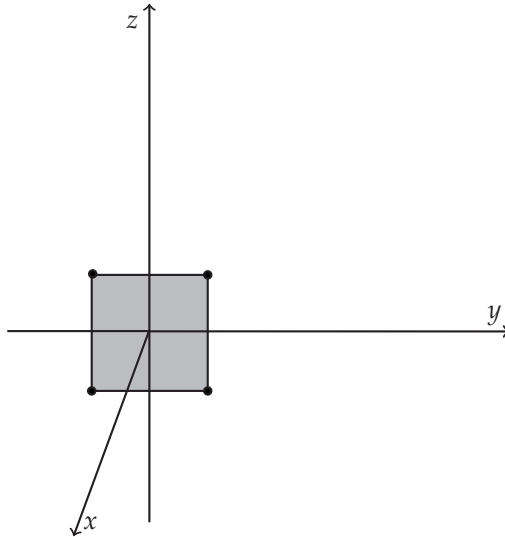

Construct a uniform rectangular array with two elements along the y -axis and three elements along the z -axis.

```
Ha = phased.URA([2 3])
ElementLocs2by3 = getElementPosition(Ha)
```

Local Coordinate System of a Conformal Array

In a conformal array, the phase center of the array may be defined at an arbitrary point. In principle, the orientation of each element in a conformal array may be different. Therefore, it is convenient to define the array by giving the element locations with respect to the local coordinate system origin along with the azimuth and elevation angles defining the boresight directions.

Construct a default conformal array:

```
H = phased.ConformalArray
% query element position and element normal
H.ElementPosition
H.ElementNormal
```

The default conformal array consists of a single element located at $[0\ 0\ 0]$, the origin of the local coordinate system. The boresight direction of the single

element is specified by the azimuth and elevation angles (in degrees) in the `ElementNormal` property, `[0 0]`.

Construct a conformal array with three elements located at `[1 0 0]`, `[0 1 0]`, and `[0 -1 0]` with respect to the origin. Define the normal direction to the first element as 0 degrees azimuth and elevation. Define the normal direction to the second and third elements as 45 degrees azimuth and elevation.

```
H = phased.ConformalArray(...  
    'ElementPosition',[1 0 0; 0 1 0; 0 -1 0]',...  
    'ElementNormal',[0 45 45; 0 45 45])
```

Converting Between Global and Local Coordinate Systems

In many array processing applications, it is necessary to convert between global and local coordinates. Two utility functions, `global2localcoord` and `local2globalcoord`, enable you to do this conversion.

Convert Local Spherical Coordinates to Global Rectangular Coordinates

Assume a stationary target 1000 meters from a URA at an azimuth angle of 30 degrees and elevation angle of 45 degrees. The phase center of the URA is located at the rectangular coordinates `[1000 500 100]` in the global coordinate system. The local coordinate axes of the URA are parallel to the global coordinate axes. Determine the position of the target in rectangular coordinates in the global coordinate system.

In this example, the target's location is specified in local spherical coordinates. The target is 1000 meters from the array, which means that $R=1000$. The azimuth angle of 30 degrees and elevation angle of 45 degrees give the direction of the target from the array. The spherical coordinates of the target in the local coordinate system are `(30,45,1000)`. To convert to global rectangular coordinates, you must know the position of the array in global coordinates. The phase center of the array is located at `[1000 500 100]`. To convert from local spherical coordinates to global rectangular coordinates, use the `'sr'` option.

```
gCoord = local2globalcoord([30; 45; 1000],'sr',...  
    [1000; 500; 100]);
```

Convert Global Rectangular Coordinates to Local Spherical Coordinates

Assume a stationary target with global rectangular coordinates [5000 3000 50]. The phase center of a URA has global rectangular coordinates [1000 500 10]. The local coordinate axes of the URA are [0 1 0], [1 0 0], and [0 0 -1]. Determine the position of the target in local spherical coordinates.

```
lCoord = global2localcoord([5000; 3000; 50], 'rs', ...  
    [1000; 500; 10], [0 1 0; 1 0 0; 0 0 -1]);
```

The output `lCoord` is in the form (az, el, R) . The target in local coordinates has an azimuth of approximately 58 degrees, an elevation of 0.5 degrees, and a range of 4717.16 m.

Motion Modeling in Phased Array Systems

In this section...

“Support for Motion Modeling” on page 10-30

“Platform Motion with Constant Velocity” on page 10-31

“Platform Motion with Nonconstant Velocity” on page 10-32

“Track Range and Angle Changes Between Platforms” on page 10-33

Support for Motion Modeling

A critical component in phased array system applications is the ability to model motion in space. Such modeling includes the motion of arrays, targets, and sources of interference. For convenience, you can ignore the distinction between these objects and collectively model the motion of a platform.

Extended bodies can undergo both translational and rotational motion in space. Phased Array System Toolbox software supports modeling of translational motion.

Modeling translational platform motion requires the specification of a position and velocity vector. Specification of a position vector implies a coordinate system. In the Phased Array System Toolbox, platform position and velocity are specified in a “Global Coordinate System” on page 10-23. You can think of the platform position as the displacement vector from the global origin or as the coordinates of a point with respect to the global origin.

Let r_0 denote the position vector at time 0 and v denote the velocity vector. The position vector of a platform as a function of time, $r(t)$, is:

$$r(t) = r_0 + vt$$

The following figure depicts the vector interpretation of translational motion.

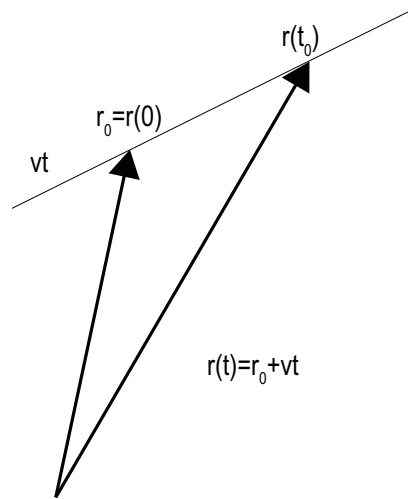

When the platform represents a sensor element or array, it is important to know the orientation of the element or array *local coordinate axes*. For example, the orientation of the local coordinate axes is necessary to extract angle information from incident waveforms. See “Global and Local Coordinate Systems” on page 10-23 for a description of global and local coordinate systems in the software. Finally, for platforms with nonconstant velocity, you must be able to update the velocity vector over time.

You can model platform position, velocity, and local axes orientation with the `phased.Platform` object.

Platform Motion with Constant Velocity

Beginning with a simple example, model the motion of a platform over ten time steps. To determine the time step, assume that you have a pulse transmitter with a pulse repetition frequency (PRF) of 1 kilohertz. Accordingly, the time interval between each pulse is 1 millisecond. Set the time step equal to pulse repetition interval.

```
PRF = 1e3;
Tstep = 1/PRF;
Nsteps = 10;
```

Next, construct a platform object specifying the platform's initial position and velocity. Assume that the initial position of the platform is 100 meters (m) from the origin at (60,80,0). Assume the speed is approximately 30 meters per second (m/s) with the constant velocity vector given by (15, 25.98, 0).

```
hplat = phased.Platform('InitialPosition',[60;80;0], ...  
    'Velocity', [15;25.98;0]);
```

The orientation of the local coordinate axes of the platform is the value of the `OrientationAxes` property. You can view the value of this property by entering `hplat.OrientationAxes` at the MATLAB command prompt. Because the `OrientationAxes` property is not specified in the construction of the `phased.Platform` object, the property is assigned its default value of `[1 0 0;0 1 0;0 0 1]`.

Use the `step` method to simulate the translational motion of the platform.

```
InitialPos = hplat.InitialPosition;  
for k = 1:Nsteps  
    pos = step(hplat,Tstep);  
end  
FinalPos = pos+hplat.Velocity*Tstep;  
DistTravel = norm(FinalPos-InitialPos);
```

The `step` method returns the current position of the platform and then updates the platform position based on the time step and velocity. Equivalently, the first time you invoke the `step` method, the output is the position of the platform at $t=0$.

Recall that the platform is moving with a constant velocity of approximately 30 m/s. The total time elapsed is 0.01 seconds. Invoking the `step` method returns the current position of the platform and then updates that position. Accordingly, you expect the final position to differ from the initial position by 0.30 meters. Confirm this difference by examining the value of `DistTravel`.

Platform Motion with Nonconstant Velocity

Most platforms in phased array applications do not move with constant velocity. If the time interval described by the number of time steps is small with respect to the platform's speed, you can often approximate the velocity as constant. However, there are situations where you must update the

platform's velocity over time. You can do so with `phased.Platform` because the `Velocity` property is *tunable*. See “What You Cannot Change While Your System Is Running” for details.

In this example, assume you model a target initially at rest. The initial velocity vector is (0,0,0). Assume the time step is 1 millisecond. After 500 milliseconds, the platform begins to move with a speed of approximately 10 m/s. The velocity vector is (7.07,7.07,0). The platform continues at this velocity for an additional 500 milliseconds.

```
Tstep = 1e-3;
Nsteps = 1/Tstep;
hplat = phased.Platform('InitialPosition',[100;100;0]);
for k = 1:Nsteps/2
    [pos,vel] = step(hplat,Tstep);
end
hplat.Velocity = [7.07; 7.07; 0];
for k=Nsteps/2+1:Nsteps
    [pos,vel] = step(hplat,Tstep);
end
```

Track Range and Angle Changes Between Platforms

This example uses the `phased.Platform` object to model the changes in range between a stationary radar and a moving target. The radar is located at (1000,1000,0) and has a velocity of (0,0,0). The target has an initial position of (5000,8000,0) and moves with a constant velocity of (-30,-45,0). The pulse repetition frequency (PRF) is 1 kHz. Assume that the radar emits ten pulses.

The example uses `phased.Platform` to model the motion of the target and radar. The `global2localcoord` function translates the target's rectangular coordinates in the global coordinate system to spherical coordinates in the local coordinate system of the radar.

```
PRF = 1e3;
Tstep = 1/PRF;
hradar = phased.Platform('InitialPosition',[1000;1000;0]);
htgt = phased.Platform('InitialPosition',[5000;8000;0],...
    'Velocity',[-30;-45;0]);
% Calculate initial target range and angle
[InitRng, InitAng] = rangeangle(htgt.InitialPosition,...
```

```
        hradar.InitialPosition);
% Calculate relative radial speed
v = radialspeed(htgt.InitialPosition,htgt.Velocity,...
    hradar.InitialPosition);
% Simulate target motion
Npulses = 10;                                % Number of pulses
for num = 1:Npulses
    tgtpos = step(htgt,Tstep);
end
tgtpos = tgtpos+htgt.Velocity*Tstep;
% Calculate final target range and angle
[FinalRng,FinalAng] = rangeangle(tgtpos,...
    hradar.InitialPosition);
DeltaRng = FinalRng-InitRng;
```

The constant velocity of the target is approximately 54 m/s. The total time elapsed is 0.01 seconds. The range between the target and the radar should decrease by approximately 54 centimeters. Compare the initial range of the target, `InitRng`, to the final range, `FinalRng`, to confirm that this decrease occurs.

Related Examples

- Introduction to Space-Time Adaptive Processing

Doppler Shift and Pulse-Doppler Processing

In this section...

“Support for Pulse-Doppler Processing” on page 10-35

“Converting Speed to Doppler Shift” on page 10-35

“Converting Doppler Shift to Speed” on page 10-36

“Pulse-Doppler Processing of Slow-Time Data” on page 10-36

Support for Pulse-Doppler Processing

Relative motion between a signal source and a receiver produces shifts in the frequency of the received waveform. Measuring this *Doppler* shift provides an estimate of the relative radial velocity of a moving target.

For a narrowband signal propagating at the speed of light, the one-way Doppler shift in hertz is:

$$\Delta f = \pm \frac{v}{\lambda}$$

where v is the relative radial speed of the target with respect to the transmitter. For a target approaching the receiver, the Doppler shift is positive. For a target receding from the transmitter, the Doppler shift is negative.

You can use `speed2dop` to convert the relative radial speed to the Doppler shift in hertz. You can use `dop2speed` to determine the radial speed of a target relative to a receiver based on the observed Doppler shift.

Converting Speed to Doppler Shift

Assume a target approaching a stationary receiver with a radial speed of 23 meters per second. The target is reflecting a narrowband electromagnetic wave with a frequency of 1 GHz. Estimate the one-way Doppler shift.

```
freq = 1e9;
lambda = physconst('LightSpeed')/freq;
```

```
DopplerShift = speed2dop(23,lambda)
```

The one-way Doppler shift is approximately 76.72 Hz. The fact that the target is approaching the receiver results in a positive Doppler shift.

Converting Doppler Shift to Speed

Assume you observe a Doppler shift of 400 Hz for a waveform with a frequency of 9 GHz. Determine the radial velocity of the target.

```
freq = 9e9;  
lambda = physconst('LightSpeed')/freq;  
speed = dop2speed(400,lambda)
```

The target speed is approximately 13.32 m/sec.

Pulse-Doppler Processing of Slow-Time Data

A common technique for estimating the radial velocity of a moving target is pulse-Doppler processing. In pulse-Doppler processing, you take the discrete Fourier transform (DFT) of the slow-time data from a range bin containing a target. If the pulse repetition frequency is sufficiently high with respect to the speed of the target, the target is located in the same range bin for a number of pulses. Accordingly, the slow-time data corresponding to that range bin contain information about the Doppler shift induced by the moving target, which you can use to estimate the target's radial velocity.

The slow-time data are sampled at the pulse repetition frequency (PRF) and therefore the DFT of the slow-time data for a given range bin yields an estimate of the Doppler spectrum from $[-\text{PRF}/2, \text{PRF}/2]$ Hz. Because the slow-time data are complex-valued, the DFT magnitudes are not necessarily an even function of the Doppler frequency. This removes the ambiguity between a Doppler shift corresponding to an approaching (positive Doppler shift), or receding (negative Doppler shift) target. The resolution in the Doppler domain is PRF/N where N is the number of slow-time samples. You can pad the spectral estimate of the slow-time data with zeros to interpolate the DFT frequency grid and improve peak detection, but this does not improve the Doppler resolution.

The typical workflow in pulse-Doppler processing involves:

- Detecting a target in the range dimension (fast-time samples). This gives the range bin to analyze in the slow-time dimension.
- Computing the DFT of the slow-time samples corresponding to the specified range bin. Identify significant peaks in the magnitude spectrum and convert the corresponding Doppler frequencies to speeds.

To illustrate pulse-Doppler processing with Phased Array System Toolbox software, assume that you have a stationary monostatic radar located at the global origin, [0;0;0]. The radar consists of a single isotropic antenna element. There is a target with a non-fluctuating radar cross section (RCS) of 1 square meter located initially at [1000; 1000; 0] and moving with a constant velocity of [-100; -100; 0]. The antenna operates at a frequency of 1 GHz and illuminates the target with 10 rectangular pulses at a PRF of 10 kHz.

Define the System objects needed for this example and set their properties. Seed the random number generator for the phased.ReceiverPreamp object to produce repeatable results.

```
hwav = phased.RectangularWaveform('SampleRate',5e6,...
    'PulseWidth',6e-7,'OutputFormat','Pulses',...
    'NumPulses',1,'PRF',1e4);
htgt = phased.RadarTarget('Model','Nonfluctuating',...
    'MeanRCS',1,'OperatingFrequency',1e9);
htgtloc = phased.Platform('InitialPosition',[1000; 1000; 0],...
    'Velocity',[-100; -100; 0]);
hant = phased.IsotropicAntennaElement(...
    'FrequencyRange',[5e8 5e9]);
htrans = phased.Transmitter('PeakPower',5e3,'Gain',20,...
    'InUseOutputPort',true);
htransloc = phased.Platform('InitialPosition',[0;0;0],...
    'Velocity',[0;0;0]);
hrad = phased.Radiator('OperatingFrequency',1e9,'Sensor',hant);
hcol = phased.Collector('OperatingFrequency',1e9,'Sensor',hant);
hspace = phased.FreeSpace('SampleRate',hwav.SampleRate,...
    'OperatingFrequency',1e9,'TwoWayPropagation',false);
hrx = phased.ReceiverPreamp('Gain',0,'LossFactor',0,...
    'SampleRate',5e6,'NoiseBandwidth',5e6/2,'NoiseFigure',5,...
    'EnableInputPort',true,'SeedSource','Property','Seed',1e3);
```

The following loop transmits ten successive rectangular pulses toward the target, reflects the pulses off the target, collects the reflected pulses at the receiver, and updates the target's position with the specified constant velocity.

```

NumPulses = 10;
sig = step(hwav); % get waveform
transpos = htransloc.InitialPosition; % get transmitter position
rxsig = zeros(length(sig),NumPulses);
% transmit and receive ten pulses
for n = 1:NumPulses
    % update target position
    [tgtpos,tgtvel] = step(htgtloc,1/hwav.PRF);
    [tgtrng,tgtang] = rangeangle(tgtpos,transpos);
    tpos(n) = tgtrng;
    [txsig,txstatus] = step(htrans,sig); % transmit waveform
    txsig = step(hrad,txsig,...
        tgtang); % radiate waveform toward target
    txsig = step(hspace,txsig,transpos,tgtpos,...
        [0;0;0],tgtvel); % propagate waveform to target
    txsig = step(htgt,txsig); % reflect the signal
    % propagate waveform from the target to the transmitter
    txsig = step(hspace,txsig,tgtpos,transpos,tgtvel,[0;0;0]);
    txsig = step(hcol,txsig,tgtang); % collect signal
    rxsig(:,n) = step(hrx,txsig,~txstatus); % receive the signal
end

```

`rxsig` contains the echo data in a 500-by-10 matrix where the row dimension contains the fast-time samples and the column dimension contains the slow-time samples. In other words, each row in the matrix contains the slow-time samples from a specific range bin.

Construct a linearly-spaced grid corresponding to the range bins from the fast-time samples. The range bins extend from 0 meters to the maximum unambiguous range.

```

prf = hwav.PRF;
fs = hwav.SampleRate;
fasttime = unigrid(0,1/fs,1/prf,'[]');
rangebins = (physconst('LightSpeed')*fasttime)/2;

```

The next step is to detect range bins which contain targets. In this simple scenario, no matched filtering or time-varying gain compensation is utilized. See Doppler Estimation for an example using matched filtering and range-dependent gain compensation to improve the SNR.

In this example, set the false-alarm probability to $1e-9$. Use noncoherent integration of the ten rectangular pulses and determine the corresponding threshold for detection in white Gaussian noise. Because this scenario contains only one target, take the largest peak above the threshold. Display the estimated target range.

```
probfa = 1e-9;
npower = noisepow(hrx.NoiseBandwidth,...
    hrx.NoiseFigure,hrx.ReferenceTemperature);
thresh = npwgnthresh(probfa,NumPulses,'noncoherent');
thresh = sqrt(npower * db2pow(thresh));
[pks,range_detect] = findpeaks(pulsint(rxsig,'noncoherent'),...
    'MinPeakHeight',thresh,'SortStr','descend');
range_estimate = rangebins(range_detect(1));
fprintf('Estimated range of the target is %4.2f meters.\n',...
    range_estimate);
```

Extract the slow-time samples corresponding to the range bin containing the detected target. Compute the power spectral density estimate of the slow-time samples using periodogram and find the peak frequency. Convert the peak Doppler frequency to a speed using dop2speed. A positive Doppler shift indicates that the target is approaching the transmitter. A negative Doppler shift indicates that the target is moving away from the transmitter.

```
ts = rxsig(range_detect(1),:).';
[Pxx,F] = periodogram(ts,[],256,prf,'centered');
plot(F,10*log10(Pxx)); grid;
xlabel('Frequency (kHz)');
ylabel('Power (dB)');
title('Periodogram Spectrum Estimate');
[Y,I] = max(Pxx);
lambda = physconst('LightSpeed')/1e9;
tgtspeed = dop2speed(F(I)/2,lambda);
fprintf('Estimated target speed is %3.1f m/sec.\n',tgtspeed);
if F(I)>0
    fprintf('The target is approaching the radar.\n');
```

```

else
    fprintf('The target is moving away from the radar.\n');
end

```

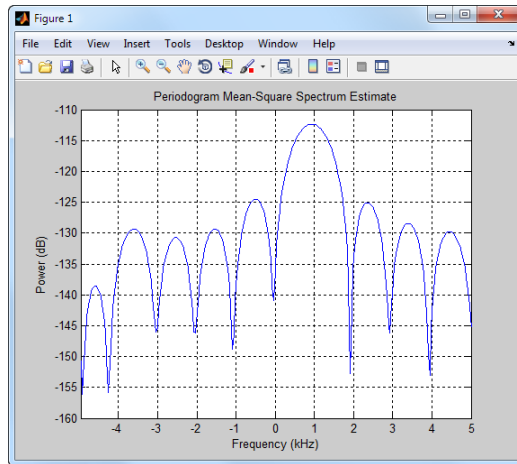

The code produces:

```

Estimated range of the target is 1439.00 meters.
Estimated target speed is 140.5 m/sec.
The target is approaching the radar.

```

The true radial speed of the target is detected within the Doppler resolution and the range of the target is detected within the range resolution of the radar.

Related Examples

- Doppler Estimation
- Scan Radar Using a Uniform Rectangular Array

Using Polarization

Polarized Fields

In this section...

“Introduction to Polarization” on page 11-2

“Linear and Circular Polarization” on page 11-4

“Elliptical Polarization” on page 11-9

“Linear and Circular Polarization Bases” on page 11-14

“Sources of Polarized Fields” on page 11-18

“Scattering Cross-Section Matrix” on page 11-26

“Polarization Loss Due to Field and Receiver Mismatch” on page 11-32

“Polarization Example” on page 11-34

Introduction to Polarization

You can use the Phased Array System Toolbox software to simulate radar systems that transmit, propagate, reflect, and receive polarized electromagnetic fields. By including this capability, the toolbox can realistically model the interaction of radar waves with targets and the environment.

It is a basic property of plane waves in free-space that the directions of the electric and magnetic field vectors are orthogonal to their direction of propagation. The direction of propagation of an electromagnetic wave is determined by the *Poynting* vector

$$\mathbf{S} = \mathbf{E} \times \mathbf{H}$$

In this equation, \mathbf{E} represents the electric field and \mathbf{H} represents the magnetic field. The quantity, \mathbf{S} , represents the magnitude and direction of the wave’s energy flux. Maxwell’s equations, when applied to plane waves, produce the result that the electric and magnetic fields are related by

$$\mathbf{E} = -Z\mathbf{s} \times \mathbf{H}$$

$$\mathbf{H} = \frac{1}{Z}\mathbf{s} \times \mathbf{E}$$

The vector \mathbf{s} , the unit vector in the \mathbf{S} direction, represents the direction of propagation of the wave. The quantity, Z , is the *wave impedance* and is a function of the electric permittivity and the magnetic permeability of medium in which the wave travels.

After manipulating the two equations, you can see that the electric and magnetic fields are orthogonal to the direction of propagation

$$\mathbf{E}\mathbf{s} = \mathbf{H}\mathbf{s} = 0.$$

This last result proves that there are really only two independent components of the electric field, labeled E_x and E_y . Similarly, the magnetic field can be expressed in terms of two independent components. Because of the orthogonality of the fields, the electric field can be represented in terms of two unit vectors orthogonal to the direction of propagation.

$$\mathbf{E} = E_x \hat{\mathbf{e}}_x + E_y \hat{\mathbf{e}}_y$$

The unit vectors together with the unit vector in direction of propagation

$$\{\hat{\mathbf{e}}_x, \hat{\mathbf{e}}_y, \mathbf{s}\}.$$

form a right-handed orthonormal triad. Later, these vectors and the coordinates they define will be related to the coordinates of a specific radar system. In radar systems, it is common to use the subscripts, H and V , denoting the horizontal and vertical components, instead of x and y . Because the electric and magnetic fields are determined by each other, only the properties of the electric field need be considered.

For a radar system, the electric and magnetic field are actually spherical waves, rather than plane waves. However, in practice, these fields are usually measured in the far field region or radiation zone of the radar source and are approximately plane waves. In the far field, the waves are called *quasi-plane* waves. A point lies in the *far field* if its distance, R , from the source satisfies $R \gg D^2/\lambda$ where D is a typical dimension of the source, whether it is a single antenna or an array of antennas.

Polarization applies to purely sinusoidal signals. The most general expression for a sinusoidal plane-wave has the form

$$\mathbf{E} = E_{x0} \cos(\omega t - \mathbf{k} \cdot \mathbf{x} + \phi_x) \hat{\mathbf{e}}_x + E_{y0} \cos(\omega t - \mathbf{k} \cdot \mathbf{x} + \phi_y) \hat{\mathbf{e}}_y = E_x \hat{\mathbf{e}}_x + E_y \hat{\mathbf{e}}_y$$

The quantities E_{x0} and E_{y0} are the real-valued, non-negative, amplitudes of the components of the electric field and ϕ_x and ϕ_y are field's phases. This expression is the most general one used for a *polarized* wave. An electromagnetic wave is *polarized* if the ratio of the amplitudes of its components and phase difference between its components do not change with time. The definition of polarization can be broadened to include *narrowband* signals, for which the bandwidth is small compared to the center or carrier frequency of the signal. The amplitude ratio and phase difference vary slowly with time when compared to the period of the wave and may be thought of as constant over many oscillations.

You can usually suppress the spatial dependence of the field and write the electric field vector as

$$\mathbf{E} = E_{x0} \cos(\omega t + \phi_x) \hat{\mathbf{e}}_x + E_{y0} \cos(\omega t + \phi_y) \hat{\mathbf{e}}_y = E_x \hat{\mathbf{e}}_x + E_y \hat{\mathbf{e}}_y$$

Linear and Circular Polarization

The preceding equation for a polarized plane wave shows that the tip of the two-dimensional electric field vector moves along a path which lies in a plane orthogonal to field's direction of propagation. The shape of the path depends upon the magnitudes and phases of the components. For example, if $\phi_x = \phi_y$, you can remove the time dependence and write

$$E_y = \frac{E_{y0}}{E_{x0}} E_x$$

This equation represents a straight line through the origin with positive slope. Conversely, suppose $\phi_x = \phi_y + \pi$. Then, the tip of the electric field vector follows a straight line through the origin with negative slope

$$E_y = -\frac{E_{y0}}{E_{x0}} E_x$$

These two polarization cases are named *linear polarized* because the field always oscillates along a straight line in the orthogonal plane. If $E_{x0} = 0$, the field is *vertically polarized*, and if $E_{y0} = 0$ the field is *horizontally polarized*.

A different case occurs when the amplitudes are the same, $E_x = E_y$, but the phases differ by $\pm\pi/2$

$$\begin{aligned} E_x &= E_0 \cos(\omega t + \phi) \\ E_y &= E_0 \cos(\omega t + \phi \pm \pi/2) = \mp E_0 \sin(\omega t + \phi) \end{aligned}$$

By squaring both sides, you can show that the tip of the electric field vector obeys the equation of a circle

$$E_x^2 + E_y^2 = E_0^2$$

While this equation gives the path the vector takes, it does not tell you in what direction the electric field vector travels around the circle. Does it rotate clockwise or counterclockwise? The rotation direction depends upon the sign of $\pi/2$ in the phase. You can see this dependency by examining the motion of the tip of the vector field. Assume the common phase angle, $\phi = 0$. This assumption is permissible because the common phase only determines starting position of the vector and does not change the shape of its path. First, look at the $+\pi/2$ case for a wave travelling along the s -direction (out of the page). At $t=0$, the vector points along the x -axis. One quarter period later, the vector points along the negative y -axis. After another quarter period, it points along the negative x -axis.

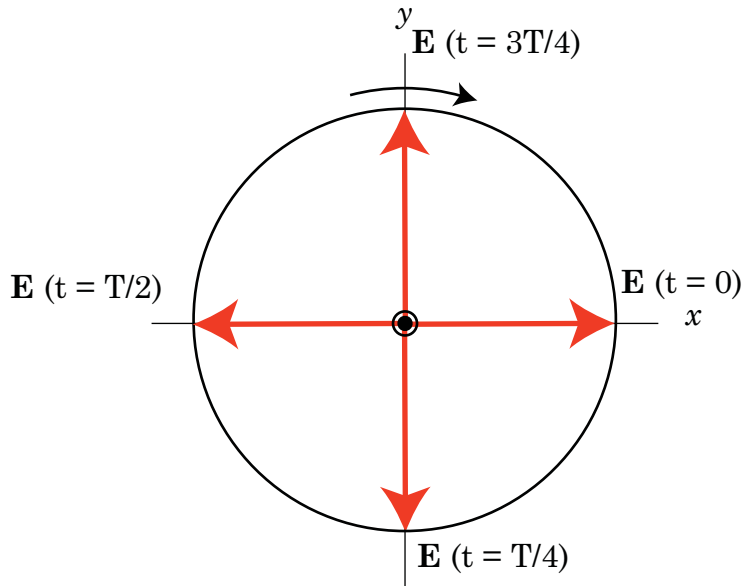

Left hand circular polarization. The direction of the electric vector at 0, 1/4, 1/2, and 3/4 periods, T . The z -axis points out of the page.

MATLAB uses the IEEE convention to assign the names *right-handed* or *left-handed* polarization to the direction of rotation of the electric vector, rather than *clockwise* or *counterclockwise*. When using this convention, left or right handedness is determined by pointing your left or right thumb along the direction of propagation of the wave. Then, align the curve of your fingers to the direction of rotation of the field at a given point in space. If the rotation follows the curve of your left hand, then the wave is left-handed polarized. If it follows the curve of your right hand, then the wave is right-handed polarized. In the preceding scenario, the field is left-handed circularly polarized (LHCP). The phase difference $-\pi/2$ corresponds to right-handed circularly polarized wave (RHCP). The following figure provides a three-dimensional view of what a LHCP electromagnetic wave looks like as it moves in the s -direction.

When the terms *clockwise* or *counterclockwise* are used they depend upon how you look at the wave. If you look along the direction of propagation, then the clockwise direction corresponds to right-handed polarization and

counterclockwise corresponds to left-handed polarization. If you look toward where the wave is coming from, then clockwise corresponds to left-handed polarization and counterclockwise corresponds to right-handed polarization.

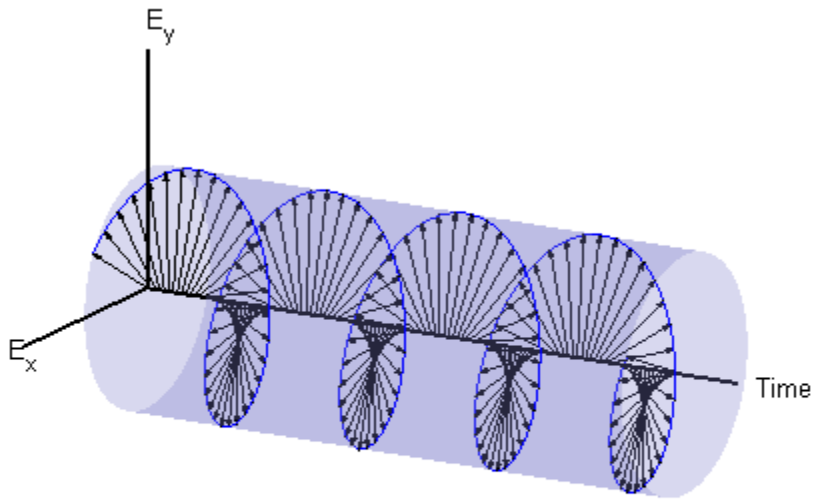

Left-Handed Circular Polarization

The figure below summarizes the appearance of linear and circularly polarized fields as they move towards you along the s -direction.

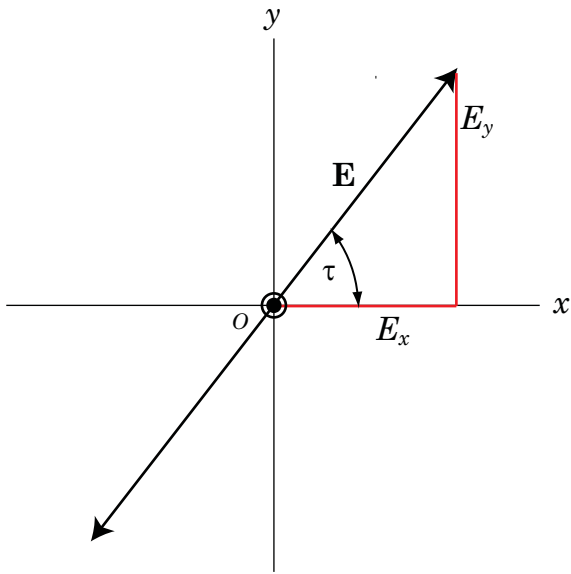

Linear polarization with positive slope

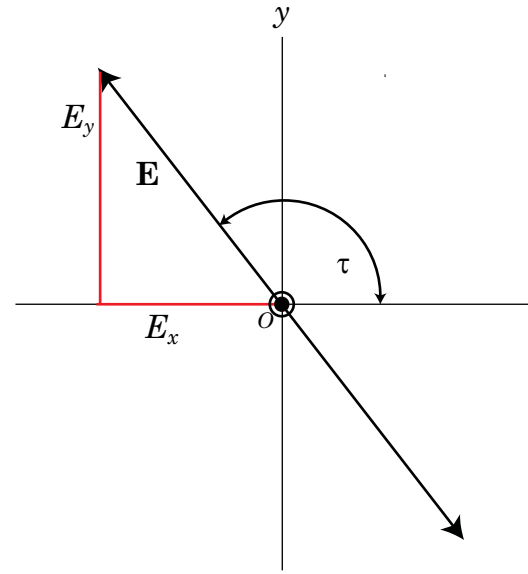

Linear polarization with negative slope

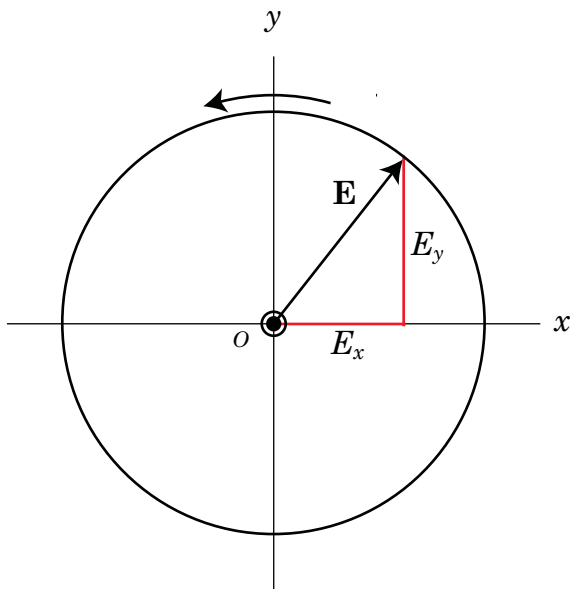

Right hand circular polarization

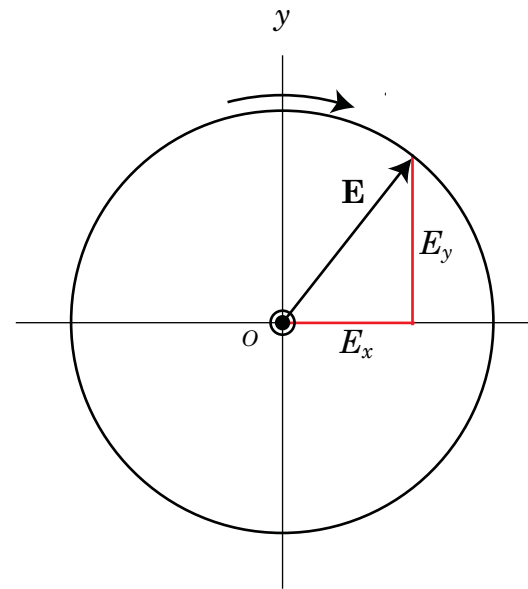

Left hand circular polarization

Elliptic Polarization

Besides the linear and circular states of polarization, a third type of polarization is *elliptic polarization*. Elliptic polarization includes linear and circular polarization as special cases.

As with linear or circular polarization, you can remove the time dependence to obtain the locus of points that the tip of the electric field vector travels

$$\left(\frac{E_x}{E_{x0}}\right)^2 + \left(\frac{E_y}{E_{y0}}\right)^2 - 2\left(\frac{E_x}{E_{x0}}\right)\left(\frac{E_y}{E_{y0}}\right)\cos\phi = \sin^2\phi$$

In this case, $\phi = \varphi_y - \varphi_x$. This equation represents a tilted two-dimensional ellipse. Its size and shape are determined by the component amplitudes and phase difference. The presence of the cross term indicates that the ellipse is tilted. The equation does not, just as in the circularly polarized case, provide any information about the rotation direction. For example, the following figure shows the instantaneous state of the electric field but does not indicate the direction in which the field is rotating.

The size and shape of a two-dimensional ellipse can be defined by three parameters. These parameters are the lengths of its two axes, the semi-major axis, a , and semi-minor axis, b , and a tilt angle, τ . The following figure illustrates the three parameters of a tilted ellipse. You can derive them from the two electric field amplitudes and phase difference.

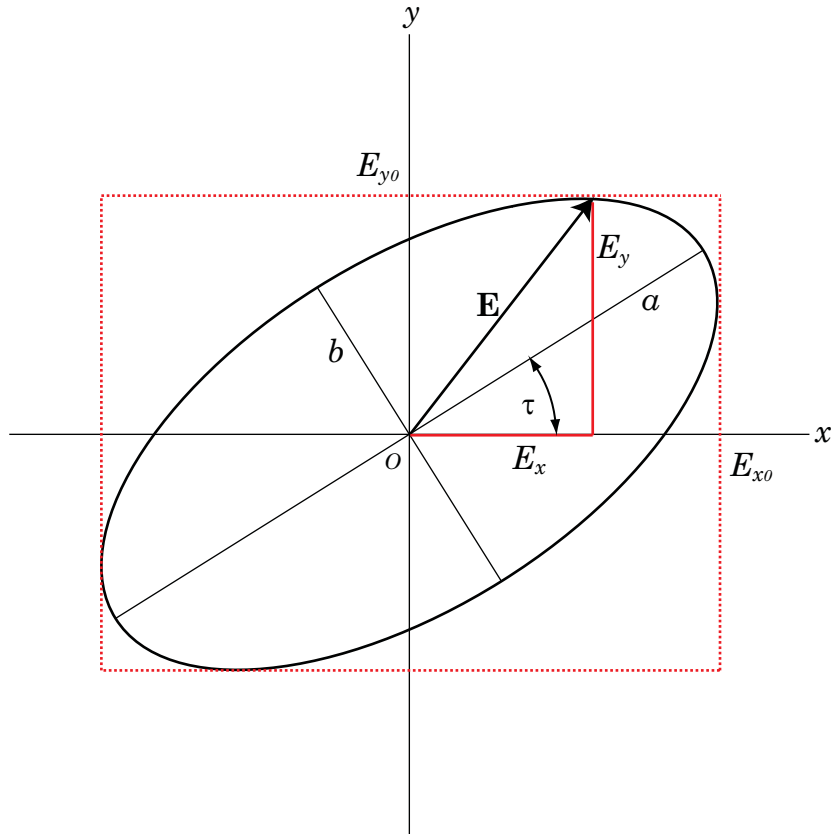

Polarization Ellipse

Polarization can best be understood in terms of complex signals. The complex representation of a polarized wave has the form

$$\mathbf{E} = E_{x0}e^{i\phi_x}e^{i\omega t}\hat{\mathbf{e}}_x + E_{y0}e^{i\phi_y}e^{i\omega t}\hat{\mathbf{e}}_y = (E_{x0}e^{i\phi_x}\hat{\mathbf{e}}_x + E_{y0}e^{i\phi_y}\hat{\mathbf{e}}_y)e^{i\omega t}$$

Define the complex *polarization ratio* as the ratio of the complex amplitudes

$$\rho = \frac{E_{y0}}{E_{x0}}e^{i(\phi_y - \phi_x)} = \frac{E_{y0}}{E_{x0}}e^{i\phi}$$

where $\phi = \phi_y - \phi_x$.

It is useful to introduce the *polarization vector*. For the complex polarized electric field above, the polarization vector, \mathbf{P} , is obtained by normalizing the electric field

$$\mathbf{P} = \frac{E_{x0}}{E_m} \hat{\mathbf{e}}_x + \frac{E_{y0}}{E_m} e^{i(\phi_y - \phi_x)} \hat{\mathbf{e}}_y = \frac{E_{x0}}{E_m} \hat{\mathbf{e}}_x + \frac{E_{y0}}{E_m} e^{i\phi} \hat{\mathbf{e}}_y$$

where $E_m^2 = E_{x0}^2 + E_{y0}^2$ is the magnitude of the wave.

The overall size of the polarization ellipse is not important because that can vary as the wave travels through space, especially through geometric attenuation. What is important is the shape of the ellipse. Thus, the significant ellipse parameters are the ratio of its axis dimensions, a/b , called the *axial ratio*, and the *tilt angle*, τ . Both of these quantities can be determined from the ratio of the component amplitudes and the phase difference, or, equivalently, from the polarization ratio. Another quantity, equivalent to the axial ratio, is the *ellipticity angle*, ϵ .

In the Phased Array System Toolbox software, you can use the `polratio` function to convert the complex amplitudes `fv=[Ey;Ex]` to the polarization ratio.

```
p = polratio(fv)
```

Tilt Angle

The tilt angle is defined as the positive (counterclockwise) rotation angle from the x -axis to the semi-major axis of the ellipse. Because of the symmetry properties of the ellipse, the tilt angle, τ , needs only be defined in the range $-\pi/2 \leq \tau \leq \pi/2$. You can find the tilt angle by determining the rotated coordinate system in which the semi-major and semi-minor axes align with the rotated coordinate axes. Then, the ellipse equation has no cross-terms. The solution takes the form

$$\tan 2\tau = \frac{2E_{x0}E_{y0}}{E_{x0}^2 - E_{y0}^2} \cos \phi$$

where $\phi = \phi_y - \phi_x$. Notice that you can rewrite this equation strictly in terms of the amplitude ratio and the phase difference.

Axial Ratio and Ellipticity Angle

After solving for the tilt angle, you can determine the semi-major and semi-minor axis lengths. Conceptually, you rotate the ellipse clockwise by the tilt angle and measure the lengths of the intersections of the ellipse with the x - and y -axes. The point of intersection with the larger value is the semi-major axis, a , and the one with the smaller value is the semi-minor axis, b .

The *axial ratio* is defined as $AR = a/b$ and, by construction, is always greater than or equal to one. The *ellipticity angle* is defined by

$$\tan \varepsilon = \mp \frac{b}{a}$$

and always lies in the range $-\pi/4 \leq \varepsilon \leq \pi/4$.

If you first introduced the *auxilliary angle*, α , by

$$\tan \alpha = \frac{E_{y0}}{E_{x0}}$$

then, the *ellipticity angle* is given by

$$\sin 2\varepsilon = \sin 2\alpha \sin \phi$$

Both the axial ratio and ellipticity angle are defined from the amplitude ratio and phase difference and are independent of the overall magnitude of the field.

Rotation Sense

For elliptic polarization, just as with circular polarization, you need another parameter to completely describe the ellipse. This parameter must provide the rotation sense or the direction that the tip of the electric (or magnetic vector) moves in time. The rate of change of the angle that the field vector makes with the x -axis is proportion to $-\sin \phi$ where ϕ is the phase difference. If $\sin \phi$ is positive, the rate of change is negative, indicating that the field has left-handed polarization. If $\sin \phi$ is negative, the rate of change is positive or right-handed polarization.

The function `polEllip` lets you find the values of the parameters of the polarization ellipse from either the field component vector $\mathbf{fv}=[E_y;E_x]$ or the polarization ratio, p .

```
fv=[Ey;Ex];
[tau,epsilon,ar,rs] = polellip(fv);
p = polratio(fv);
[tau,epsilon,ar,rs] = polellip(p);
```

The variables tau, epsilon, ar and rs represent the tilt angle, ellipticity angle, axial ratio and rotation sense, respectively. Both syntaxes give the same result.

Polarization Value Summary

This table summaries several different common polarization states and the values of the amplitudes, phases, and polarization ratio that produce them:

Polarization	Amplitudes	Phases	Polarization Ratio
Linear positive slope	Any non-negative real values for E_x, E_y .	$\varphi_y = \varphi_x$	Any non-negative real number
Linear negative slope	Any non-negative real values for E_x, E_y .	$\varphi_y = \varphi_x + \pi$	Any negative real number
Right-Handed Circular	$E_x = E_y$	$\varphi_y = \varphi_x - \pi/2$	$-i$
Left-Handed Circular	$E_x = E_y$	$\varphi_y = \varphi_x + \pi/2$	i

Polarization	Amplitudes	Phases	Polarization Ratio
Right-Handed Elliptical	Any non-negative real values for E_x, E_y	$\sin(\varphi_y - \varphi_x) < 0$	$\sin(\arg \rho) < 0$
Left-Handed Elliptical	Any non-negative real values for E_x, E_y	$\sin(\varphi_y - \varphi_x) > 0$	$\sin(\arg \rho) > 0$

Linear and Circular Polarization Bases

As shown earlier, you can express a polarized electric field as a linear combination of basis vectors along the x and y directions. For example, the complex electric field vectors for the right-handed circularly polarized (RHCP) wave and the left-handed circularly polarized (LHCP) wave, take the form:

$$\mathbf{E} = \text{Re}[E_0(\mathbf{e}_x \mp i\mathbf{e}_y)e^{i(\omega t + \phi)}]$$

In this equation, the positive sign is for the LHCP field and the negative sign is for the RHCP field. These two special combinations can be given a new name. Define a new basis vector set, called the circular basis set

$$\mathbf{e}_r = \frac{1}{\sqrt{2}}(\mathbf{e}_x - i\mathbf{e}_y)$$

$$\mathbf{e}_l = \frac{1}{\sqrt{2}}(\mathbf{e}_x + i\mathbf{e}_y)$$

You can express any polarized field in terms of the circular basis set instead of the linear basis set. Conversely, you can also write the linear polarization basis in terms of the circular polarization basis

$$\mathbf{e}_x = \frac{1}{\sqrt{2}}(\mathbf{e}_r + \mathbf{e}_l)$$

$$\mathbf{e}_y = \frac{1}{\sqrt{2}i}(\mathbf{e}_r - \mathbf{e}_l)$$

Any general elliptic field can be written as a combination of circular basis vectors

$$\mathbf{E} = E_l \mathbf{e}_l + E_r \mathbf{e}_r$$

Jones Vector

The polarized field is orthogonal to the wave's direction of propagation. Thus, the field can be completely specified by the two complex components of the electric field vector in the plane of polarization. The formulation of a polarized wave in terms of two-component vectors is called the *Jones vector* formulation. The Jones vector formulation can be expressed in either a linear basis or a circular basis or any basis. This table shows the representation of common polarizations in a linear basis and circular basis.

Common Polarizations	Jones Vector in Linear Basis	Jones Vector in Circular Basis
Vertical	[0;1]	$1/\sqrt{2} * [-1;1]$
Horizontal	[1;0]	$1/\sqrt{2} * [1;1]$
45° Linear	$1/\sqrt{2} * [1;1]$	$1/\sqrt{2} * [1-1i;1+1i]$
135° Linear	$1/\sqrt{2} * [1;-1]$	$1/\sqrt{2} * [1+1i;1-1i]$
Right Circular	$1/\sqrt{2} * [1;-1i]$	[0;1]
Left Circular	$1/\sqrt{2} * [1;1i]$	[1;0]

Stokes Parameters and the Poincaré Sphere

The polarization ellipse is an instantaneous representation of a polarized wave. However, its parameters, the tilt angle and the ellipticity angle, are often not directly measurable, particularly at very high frequencies such as light frequencies. However, you can determine the polarization from measurable intensities of the polarized field.

The measurable intensities are the Stokes parameters, S_0 , S_1 , S_2 , and S_3 . The first Stokes parameter, S_0 , describes the total intensity of the field. The second parameter, S_1 , describes the preponderance of linear horizontally polarized intensity over linear vertically polarized intensity. The third parameter, S_2 , describes the preponderance of linearly +45° polarized intensity over linearly

135° polarized intensity. Finally, S_3 describes the preponderance of right circularly polarized intensity over left circularly polarized intensity. The Stokes parameters are defined as

$$\begin{aligned} S_0 &= E_{x0}^2 + E_{y0}^2 \\ S_1 &= E_{x0}^2 - E_{y0}^2 \\ S_2 &= 2E_{x0}E_{y0} \cos \phi \\ S_3 &= 2E_{x0}E_{y0} \sin \phi \end{aligned}$$

For completely polarized fields, you can show by time averaging the polarization ellipse equation that

$$S_0^2 = S_1^2 + S_2^2 + S_3^2$$

Thus, there are only three independent Stokes' parameters.

For partially polarized fields, in contrast, the Stokes parameters satisfy the inequality

$$S_0^2 < S_1^2 + S_2^2 + S_3^2$$

The Stokes parameters are related to the tilt and ellipticity angles, τ and ε

$$\begin{aligned} S_1 &= S_0 \cos 2\tau \cos 2\varepsilon \\ S_2 &= S_0 \sin 2\tau \cos 2\varepsilon \\ S_3 &= S_0 \sin 2\varepsilon \end{aligned}$$

and inversely by

$$\begin{aligned} \tan 2\tau &= \frac{S_2}{S_1} \\ \sin 2\varepsilon &= \frac{S_3}{S_0} \end{aligned}$$

After you measure the Stokes' parameters, the shape of the ellipse is completely determined by the preceding equations.

The two-dimensional Poincaré sphere can help you visualize the state of a polarized wave. Any point on or in the sphere represents a state of polarization determined by the four Stokes parameters, S_0 , S_1 , S_2 , and S_3 . On the Poincaré sphere, the angle from the S_1 - S_2 plane to a point on the sphere is twice the ellipticity angle, ϵ . The angle from the S_1 -axis to the projection of the point into the S_1 - S_2 plane is twice the tilt angle, τ .

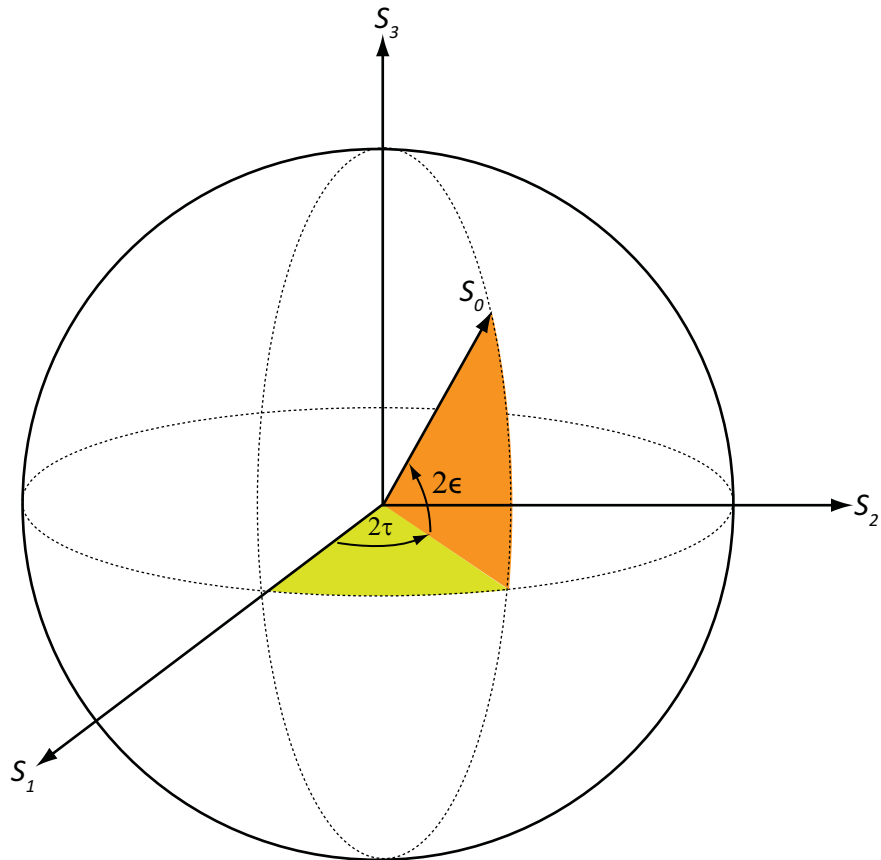

As an example, solve for the Stokes parameters of a RHCP field, $\mathbf{fv}=[1, -i]$, using the stokes function.

```
S = stokes(fv)
```

S =

2
0
0
-2

Sources of Polarized Fields

Antennas couple propagating electromagnetic radiation to electrical currents in wires, electromagnetic fields in waveguides or aperture fields. This coupling is a phenomenon common to both transmitting and receiving antennas. For some transmitting antennas, source currents in a wire produce electromagnetic waves that carrying power in all directions. Sometimes an antenna provides a means for a guided electromagnetic wave on a transmission line to transition to free-space waves such as a waveguide feeding a dish antennas. For receiving antennas, electromagnetic fields can induce currents in wires to generate signals to be then amplified and passed on to a detector.

For transmitting antennas, the shape of the antenna is chosen to enhance the power projected into a given direction. For receiving antennas, you choose the shape of the antenna to enhance the power received from a particular direction. Often, many transmitting antennas or receiving antennas are formed into an *array*. Arrays increase the transmitted power for a transmitting system or the sensitivity for a receiving system. They improve directivity over a single antenna.

An antenna can be assigned a polarization. The polarization of a transmitting antenna is the polarization of its radiated wave in the far field. The polarization of a receiving antenna is actually the polarization of a plane wave, from a given direction, resulting in maximum power at the antenna terminals. By the reciprocity theorem, all transmitting antennas can serve as receiving antennas and vice versa.

Each antenna or array has an associated local Cartesian coordinate system (x,y,z) as shown in the following figure. See “Global and Local Coordinate Systems” on page 10-23 for more information. The local coordinate system can also be represented by a spherical coordinate system using azimuth, elevation and range coordinates, az, el, r , or alternately written, (φ,θ,r) , as shown. At each point in the far field, you can create a set of unit spherical basis

vectors, $\{\hat{\mathbf{e}}_H, \hat{\mathbf{e}}_V, \hat{\mathbf{r}}\}$. The basis vectors are aligned with the (φ, θ, r) directions, respectively. In the far field, the electric field is orthogonal to the unit vector $\hat{\mathbf{r}}$. The components of a polarized field with respect to this basis, (E_H, E_V) , are called the horizontal and vertical components of the polarized field. In radar, it is common to use (H, V) instead of (x, y) to denote the components of a polarized field. In the far field, the polarized electric field takes the form

$$\mathbf{E} = \mathbf{F}(\varphi, \theta) \frac{e^{ikr}}{r} = (F_H(\varphi, \theta)\mathbf{e}_H + F_V(\varphi, \theta)\mathbf{e}_V) \frac{e^{ikr}}{r}$$

In this equation, the quantity $\mathbf{F}(\varphi, \theta)$ is called the *vector radiation pattern* of the source and contains the angular dependence of the field in the far-field region.

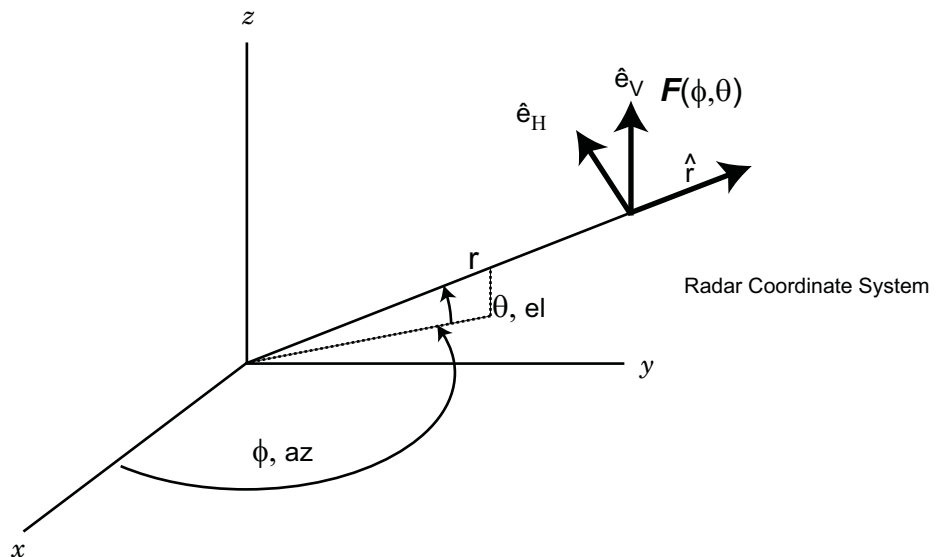

Short Dipole Antenna Element

The simplest antenna is the dipole antenna which consist of a split length of wire coupled at the middle to a coaxial cable. The simplest dipole, from a mathematical perspective, is the *Hertzian* dipole, in which the length of wire is much shorter than a wavelength. A diagram of the short dipole antenna of length L appears in the next figure. This antenna is fed by a coaxial feed

which splits into two equal length wires of length $L/2$. The current, I , moves along the z -axis and is assumed to be the same at all points in the wire.

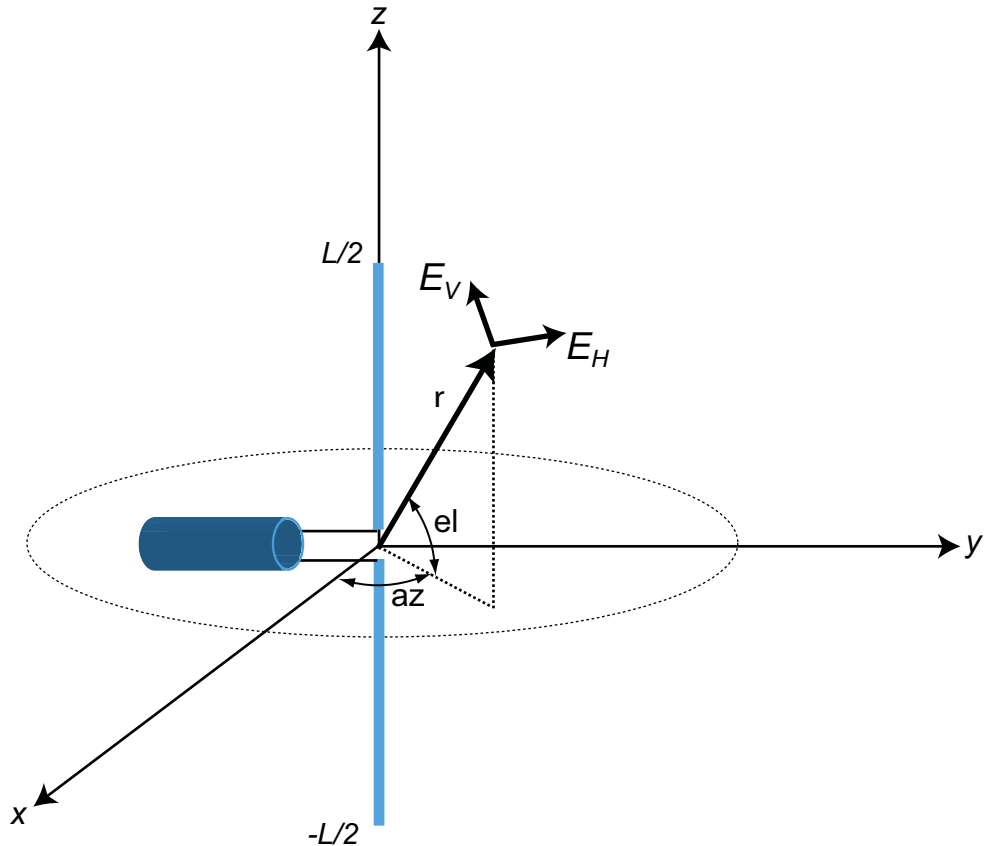

The electric field in the far field has the form

$$\begin{aligned}
 E_r &= 0 \\
 E_H &= 0 \\
 E_V &= -\frac{iZ_0IL}{2\lambda} \cos el \frac{e^{-ikr}}{r}
 \end{aligned}$$

The next figure shows how the vertical and horizontal polarization components of the field depend on the elevation angle for all values of azimuth angle because the field is axially symmetric. The horizontal component vanishes.

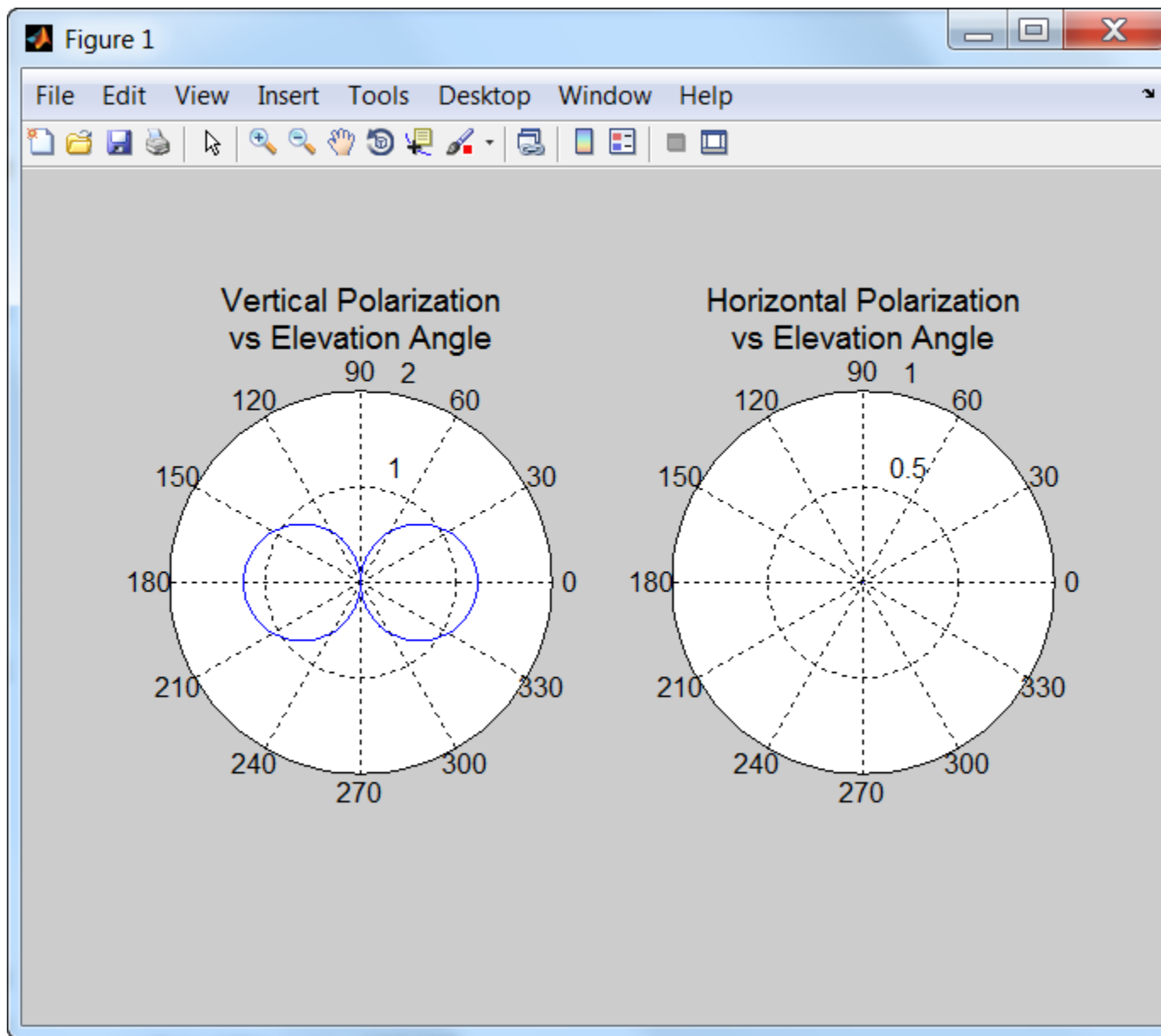

The toolbox models the short dipole antenna in the `phased.ShortDipoleAntennaElement` System object.

Crossed Dipole Antenna Element

The crossed dipole antenna comprises two identical but orthogonal short dipole antennas which are phased 90° apart. A diagram of the crossed dipole antenna appears in the following figure. You use this antenna to generate circularly polarized radiation. The electric field created by a crossed-dipole antenna constructed from a y -directed short dipole and a z -directed short dipole has the form

$$E_r = 0$$

$$E_H = -\frac{iZ_0IL}{2\lambda} \cos az \frac{e^{-ikr}}{r}$$

$$E_V = \frac{iZ_0IL}{2\lambda} (\sin el \sin az + i \cos el) \frac{e^{-ikr}}{r}$$

The polarization ratio E_V/E_H when evaluated along the x -axis is just $-i$ which means that the polarization is exactly RHCP along the x -axis. It is predominantly RHCP when the observation point is close to the x -axis. Away from the x -axis, the field is a mixture of LHCP and RHCP polarizations. Along the $-x$ -axis, the field is LHCP polarized. The figure illustrates, for a point near the x , that the field is primarily RHCP.

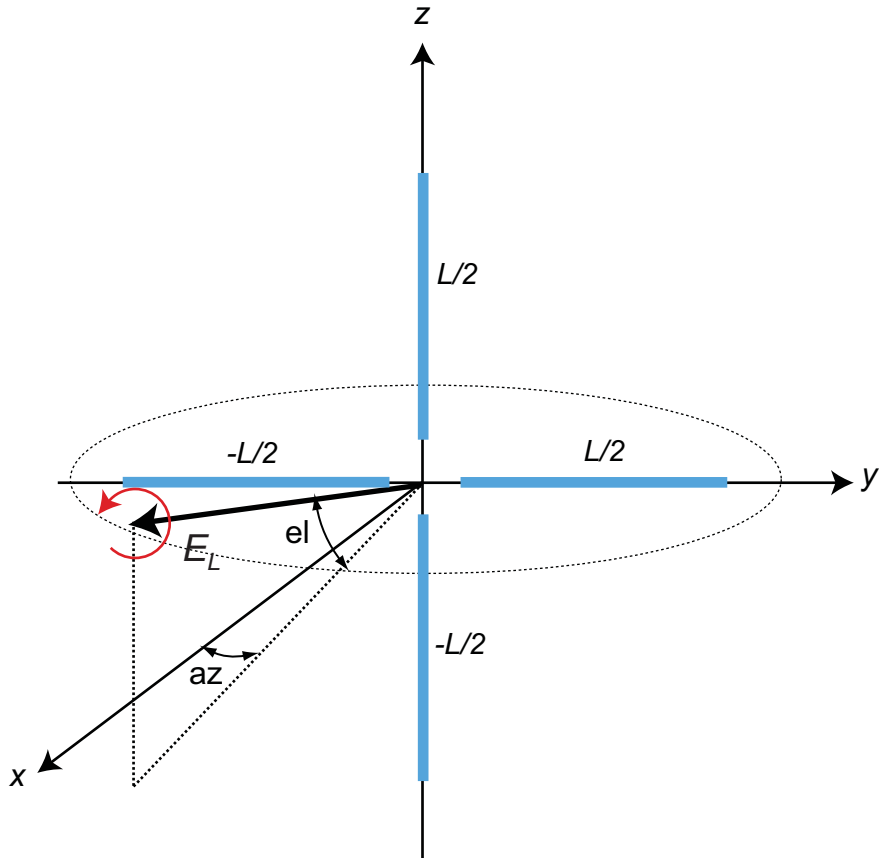

You can see in the next figure how the circular polarization changes from pure RHCP at 0° azimuth angle to LHCP at 180° azimuth angle, both at 0° elevation.

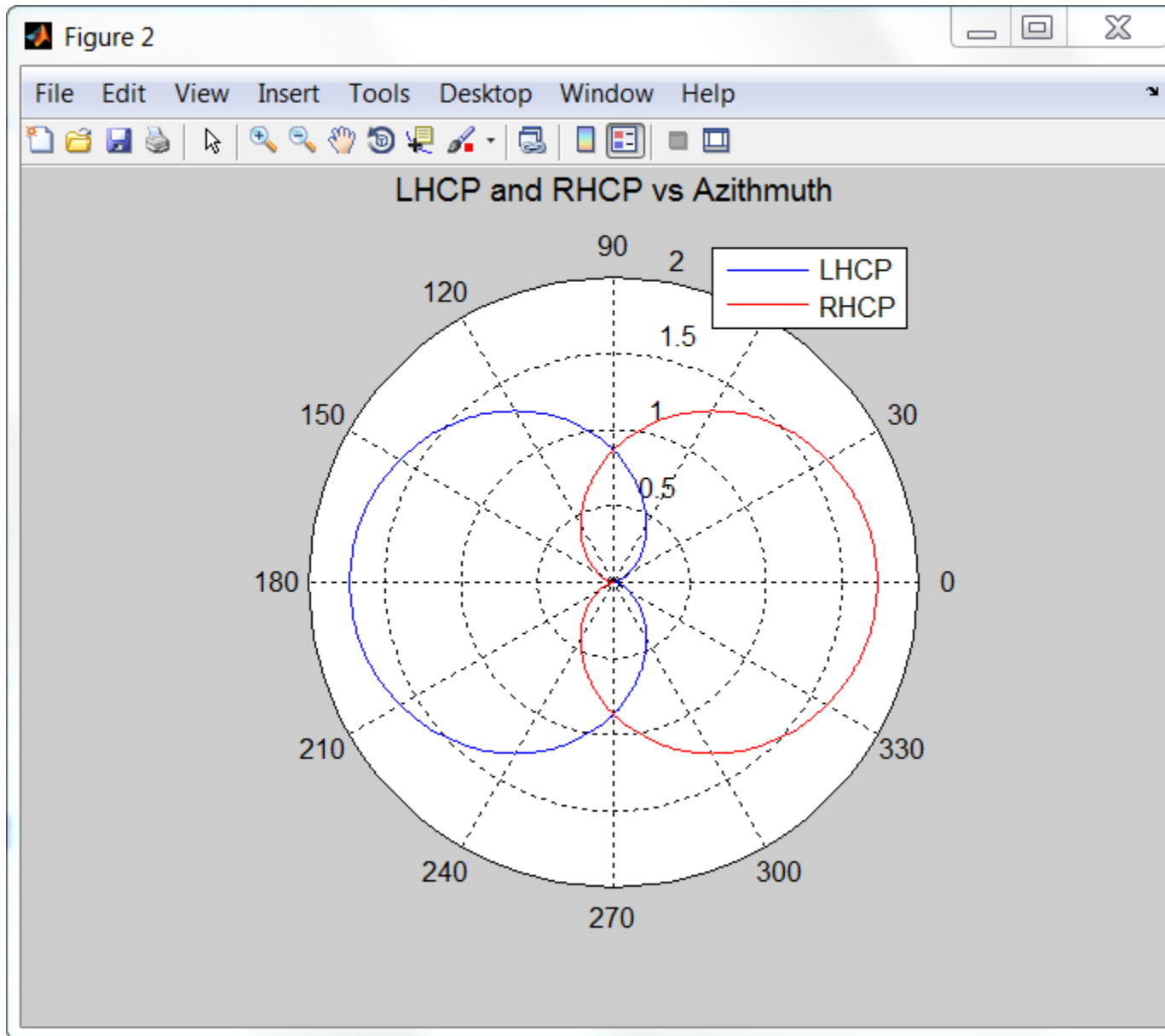

The toolbox models a crossed dipole antenna using the `phased.CrossedDipoleAntennaElement` System object.

Besides modeling antennas, the toolbox models several kinds of antenna arrays:

- `phased.ULA` for uniform line arrays
- `phased.URA` for uniform rectangular arrays
- `phased.ConformalArray` for arbitrary arrays of elements

You can create polarized fields from arrays by using polarized antenna elements as a value of the `Elements` property of an array System object.

Scattering Cross-Section Matrix

After a polarized field is created by an antenna system, the field radiates to the far-field region. When the field propagates into free space, the polarization properties remain unchanged until the field interacts with a material substance which scatters the field into many directions. In such situations, the amplitude and polarization of the scattered wave can differ from the incident wave polarization. The scattered wave polarization may depend upon the direction in which the scattered wave is observed. The exact way that the polarization changes depends upon the properties of the scattering object. The quantity describing the response of an object to the incident field is called the radar scattering cross-section matrix (RCSM), S . You can measure the scattering matrix as follows. When a unit amplitude horizontally polarized wave is scattered, both a horizontal and a vertical scattered component are produced. Call these two components S_{HH} and S_{VH} . These components are complex numbers containing the amplitude and phase changes from the incident wave. Similarly, when a unit amplitude vertically polarized wave is scattered, the horizontal and vertical scattered component produced are S_{HV} and S_{VV} . Because, any incident field can be decomposed into horizontal and vertical components, you can arrange these quantities into a matrix and write the scattered field in terms of the incident field

$$\begin{bmatrix} E_H^{(scat)} \\ E_V^{(scat)} \end{bmatrix} = \sqrt{\frac{4\pi}{\lambda^2}} \begin{bmatrix} S_{HH} & S_{VH} \\ S_{HV} & S_{VV} \end{bmatrix} \begin{bmatrix} E_H^{(inc)} \\ E_V^{(inc)} \end{bmatrix} = \sqrt{\frac{4\pi}{\lambda^2}} [S] \begin{bmatrix} E_H^{(inc)} \\ E_V^{(inc)} \end{bmatrix}$$

In general, the scattering cross-section matrix depends upon the angles that the incident and scattered fields make with the object. When the incident field is scattered back to the transmitting antenna or, *backscattered*, the scattering matrix is symmetric.

Polarization Signature

To understand how the scattered wave depends upon the polarization of the incident wave, you need to examine all possible scattered field polarizations for each incident polarization. Because this amount of data is difficult to visualize, consider two cases:

- The scattered polarization has the same polarization as the incident field (*copolarization*)
- The scattered polarization has orthogonal polarization to the incident field (*cross-polarization*)

You can represent the incident polarizations in terms of the tilt angle-ellipticity angle pair (τ, ε) . Every unit incident polarization vector can be expressed as

$$\begin{bmatrix} E_H^{(inc)} \\ E_V^{(inc)} \end{bmatrix} = \begin{bmatrix} \cos \tau & -\sin \tau \\ \sin \tau & \cos \tau \end{bmatrix} \begin{bmatrix} \cos \varepsilon \\ j \sin \varepsilon \end{bmatrix}$$

while the orthogonal polarization vector is

$$\begin{bmatrix} E_H^{(inc)\perp} \\ E_V^{(inc)\perp} \end{bmatrix} = \begin{bmatrix} -\sin \tau & -\cos \tau \\ \cos \tau & -\sin \tau \end{bmatrix} \begin{bmatrix} \cos \varepsilon \\ -j \sin \varepsilon \end{bmatrix}$$

To form the copolarization signature, use the RCSM matrix, S , to compute:

$$P^{(co)} = \begin{bmatrix} E_H^{(inc)} & E_V^{(inc)} \end{bmatrix}^* S \begin{bmatrix} E_H^{(inc)} \\ E_V^{(inc)} \end{bmatrix}$$

where $[\]^*$ denotes complex conjugation. For the cross-polarization signature, compute

$$P^{(cross)} = \begin{bmatrix} \mathbf{E}_H^{(inc)\perp} & \mathbf{E}_V^{(inc)\perp} \end{bmatrix}^* S \begin{bmatrix} \mathbf{E}_H^{(inc)} \\ \mathbf{E}_V^{(inc)} \end{bmatrix}$$

You can compute both the copolarization and cross polarization signatures using the `polsignature` function. This function returns the absolute value of the scattered power (normalized by its maximum value). The next example shows how to plot the copolarization signature for the RCSM matrix

$$S = \begin{bmatrix} 2i & \frac{1}{2} \\ \frac{1}{2} & i \end{bmatrix}$$

for all possible incident polarizations. The range of values of the ellipticity angle and tilt span the entire possible range of polarizations.

```
rscmat = [1i*2,0.5; 0.5, -1i];  
el = [-45:45];  
tilt = [-90:90];  
polsignature(rscmat,'c',el,tilt);
```

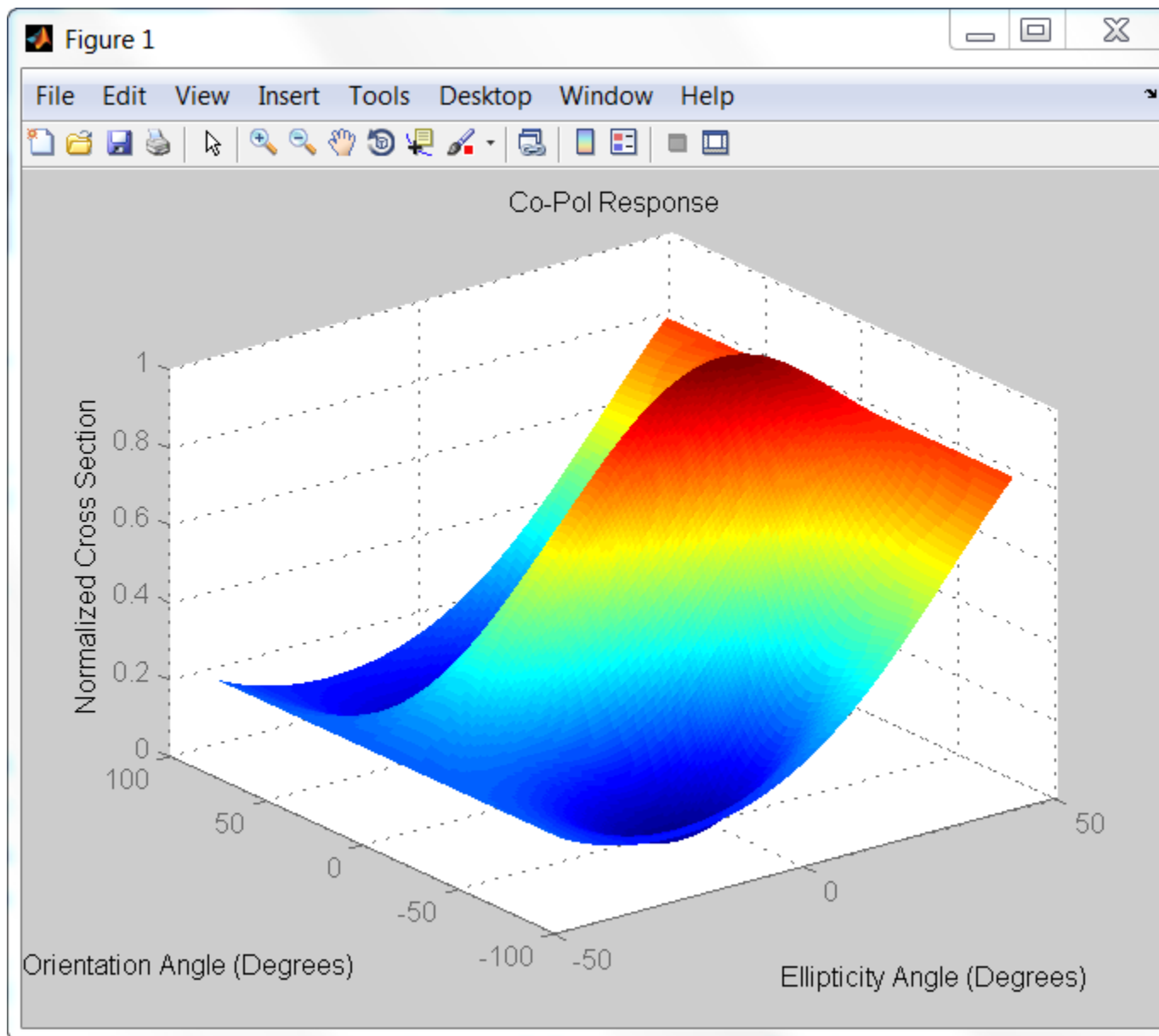

Alternatively, the code generates a plot of cross-polarizations for all incident polarizations.

```
rscmat = [1i*2,0.5; 0.5,-1i];  
el = [-45:45];  
tilt = [-90:90];  
polsignature(rscmat,'x',el,tilt);
```

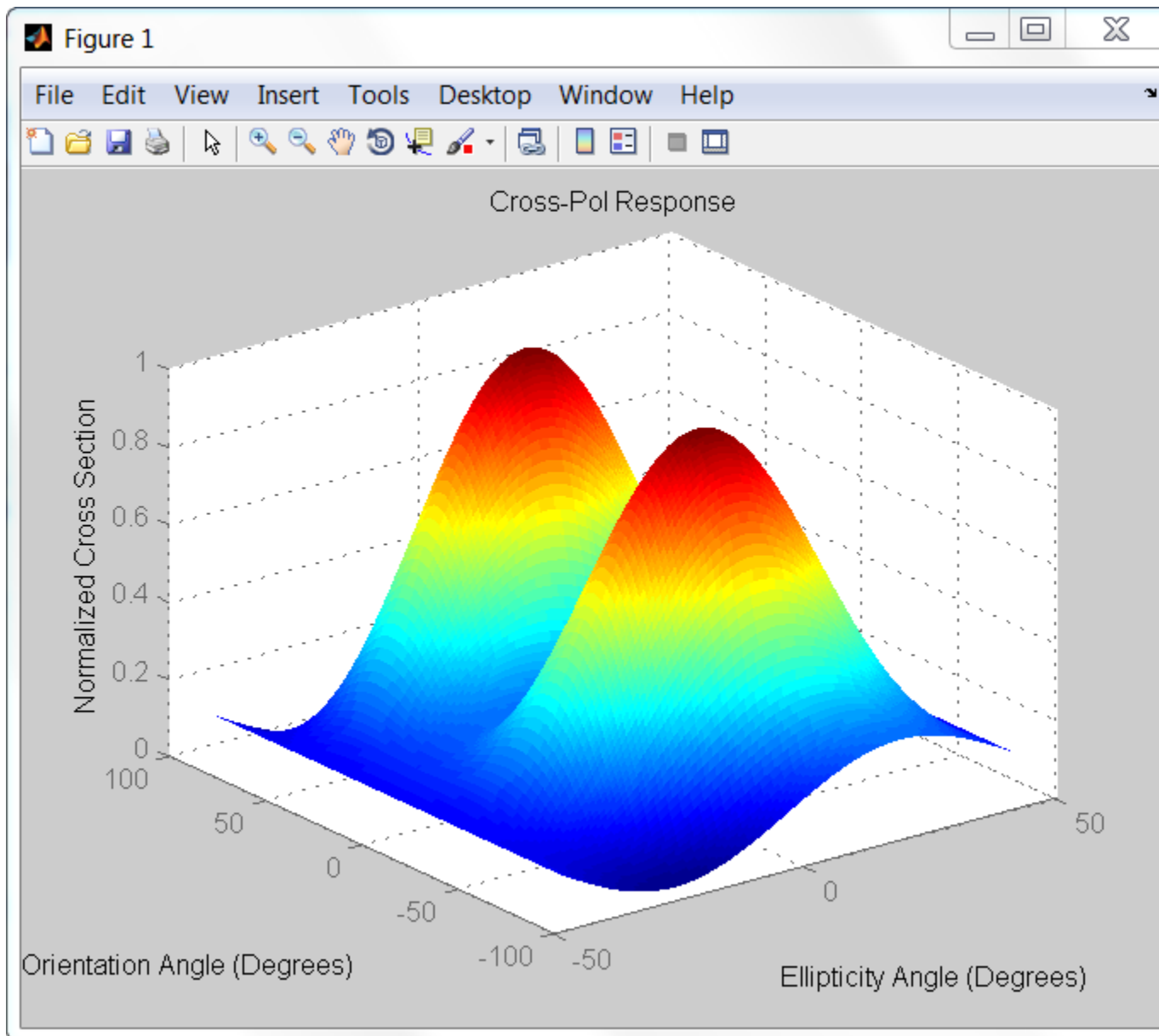
Polarization Loss Due to Field and Receiver Mismatch

An antenna that is used to receive polarized electromagnetic waves achieves its maximum output power when the antenna polarization is matched to the polarization of the incident electromagnetic field. Otherwise, there is polarization loss:

- The polarization loss is computed from the projection (or dot product) of the transmitted field's electric field vector onto the receiver polarization vector.
- Loss occurs when there is a mismatch in direction of the two vectors, not in their magnitudes.
- The polarization loss factor describes the fraction of incident power that has the correct polarization for reception.

Using the transmitter's spherical basis at the receiver's position, you can represent the incident electric field, (E_{iH}, E_{iV}) , by

$$\mathbf{E} = E_{iH}\hat{\mathbf{e}}_H + E_{iV}\hat{\mathbf{e}}_V = E_m\mathbf{P}_i$$

You can represent the receiver's polarization vector, (P_H, P_V) , in the receiver's local spherical basis by:

$$\mathbf{P} = P_H\hat{\mathbf{e}}'_H + P_V\hat{\mathbf{e}}'_V$$

The next figure shows the construction of the transmitter and receiver spherical basis vectors.

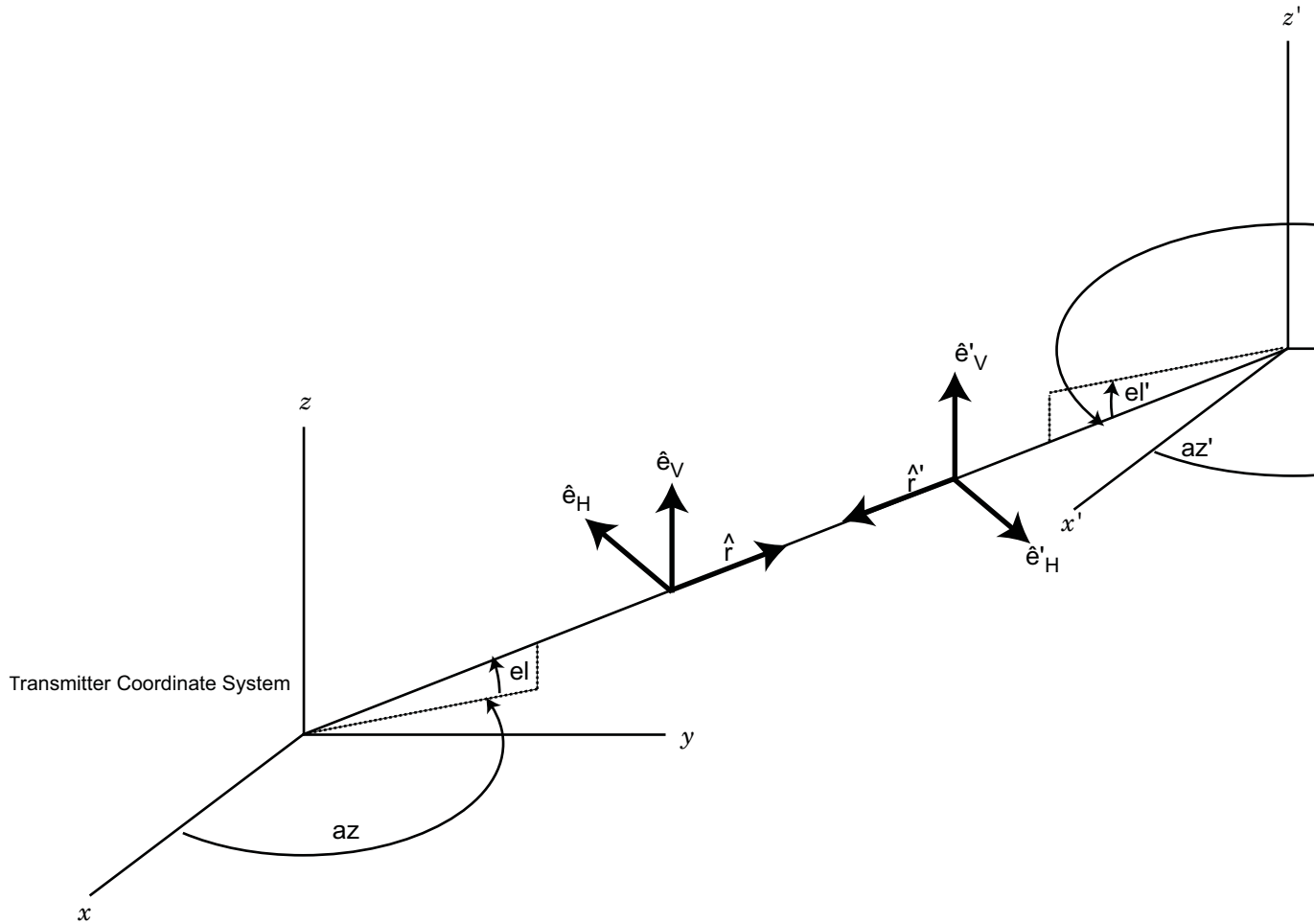

The polarization loss is defined by:

$$\rho = \frac{|\mathbf{E}_i \cdot \mathbf{P}|^2}{|\mathbf{E}_i|^2 |\mathbf{P}|^2}$$

and varies between 0 and 1. Because the vectors are defined with respect to different coordinate systems, they must be converted to the global coordinate system to form the projection. The toolbox function `polloss` computes the polarization mismatch between an incident field and a polarized antenna.

To achieve maximum output power from a receiving antenna, the matched antenna polarization vector must be the complex conjugate of the incoming field's polarization vector. As an example, if the incoming field is RHCP, with

polarization vector given by $\mathbf{e}_r = \frac{1}{\sqrt{2}}(\mathbf{e}_x - i\mathbf{e}_y)$, the optimum receiver antenna polarization is LHCP. The introduction of the complex conjugate is needed because field polarizations are described with respect to its direction of propagation, whereas the polarization of a receive antenna is usually specified in terms of the direction of propagation towards the antenna. The complex conjugate corrects for the opposite sense of polarization when receiving.

As an example, if the transmitting antenna is transmits an RHCP field, the polarization loss factors for various received antenna polarizations are

Receive Antenna Polarization	Receive Antenna Polarization Vector	Polarization Loss Factor	Polarization Loss Factor (dB)
Horizontal linear	\mathbf{e}_H	1/2	3 dB
Vertical linear	\mathbf{e}_V	1/2	3
RHCP	$\mathbf{e}_r = \frac{1}{\sqrt{2}}(\mathbf{e}_x - i\mathbf{e}_y)$	0	∞
LHCP	$\mathbf{e}_l = \frac{1}{\sqrt{2}}(\mathbf{e}_x + i\mathbf{e}_y)$	1	0

Polarization Example

This example models a tracking radar based on a 31-by-31 (961-element) uniform rectangular array (URA). The radar is designed to follow a moving target. At each time instant, the radar points in the known direction of the target. The basic radar requirements are the probability of detection, p_d , the

probability of false alarm, `pfa`, the maximum unambiguous range, `max_range` and the range resolution, `range_res` (all distance units are in meters). The `range_gate` parameter limits the region of interest to a range smaller than the maximum range. The operating frequency is set in `fc`. The simulation lasts for `numpulses` pulses.

```
pd = 0.9;           % Probability of detection
pfa = 1e-6;        % Probability of false alarm
max_range = 1500*1000; % Maximum unambiguous range
range_res = 50.0;  % Range resolution
rangegate = 5*1000; % Assume all objects are in this range
numpulses = 200;   % Number of pulses to integrate
fc = 8e9;          % Center frequency of pulse
c = physconst('LightSpeed');
tmax = 2*rangegate/c; % Time of echo from object at rangegate
```

Set the pulse repetition interval, `PRI`, and pulse repetition frequency, `PRF`, from the maximum unambiguous range.

```
PRI = 2*max_range/c;
PRF = 1/PRI;
```

Set up the transmitted rectangular waveform using the `phased.RectangularWaveform` System object. The waveform pulse width, `pulse_width`, and pulse bandwidth, `pulse_bw`, are determined by the range resolution you select, `range_res`. Specify the sampling rate, `fs`, to be twice the pulse bandwidth. The sampling rate must be an integer multiple of the `PRF`. Therefore, modify the sampling rate to satisfy this condition.

```
pulse_bw = c/(2*range_res); % Pulse bandwidth
pulse_width = 1/pulse_bw;   % Pulse width
fs = 2*pulse_bw;           % Sampling rate
% fs must be an integer multiple of the PRF.
% Insure that this is true by modifying the sampling frequency.
n = ceil(fs/PRF);
fs = n*PRF;
sWav = phased.RectangularWaveform(...
    'PulseWidth',pulse_width,...
    'PRF',PRF,...
    'SampleRate',fs);
```

The array consists of short-dipole antenna elements. Using the `phased.ShortDipoleAntennaElement` System object, create a short dipole antenna element oriented along the z -axis. The frequency response of the element is chosen to lie in the range of 5-10 gigahertz.

```
sSD = phased.ShortDipoleAntennaElement(...  
    'FrequencyRange',[5e9,10e9], 'AxisDirection','Z');
```

Define a 31-by-31 Taylor tapered uniform rectangular array using the `phased.URA` System object. Set the size of the array using the number of rows, `numRows`, and the number of columns, `numCols`. The distance between elements, `d`, is slightly smaller than one-half the wavelength, `lambda`. Compute the array taper, `tw`, using separate Taylor windows for the row and column directions. Obtain the Taylor weights using the `taylorwin` function. Plot the 3-D array response using the array `phased.URA/plotResponse` method.

```
numCols = 31;  
numRows = 31;  
lambda = c/fc;  
d = 0.9*lambda/2; % Nominal spacing  
wc = taylorwin(numCols);  
wr = taylorwin(numRows);  
tw = wr*wc';  
sArray = phased.URA('Element',sSD,'Size',[numCols,numRows],...  
    'ElementSpacing',[d,d], 'Taper',tw);  
plotResponse(sArray,fc,c,'Format','Polar','Polarization','V',...  
    'RespCut','3D');
```

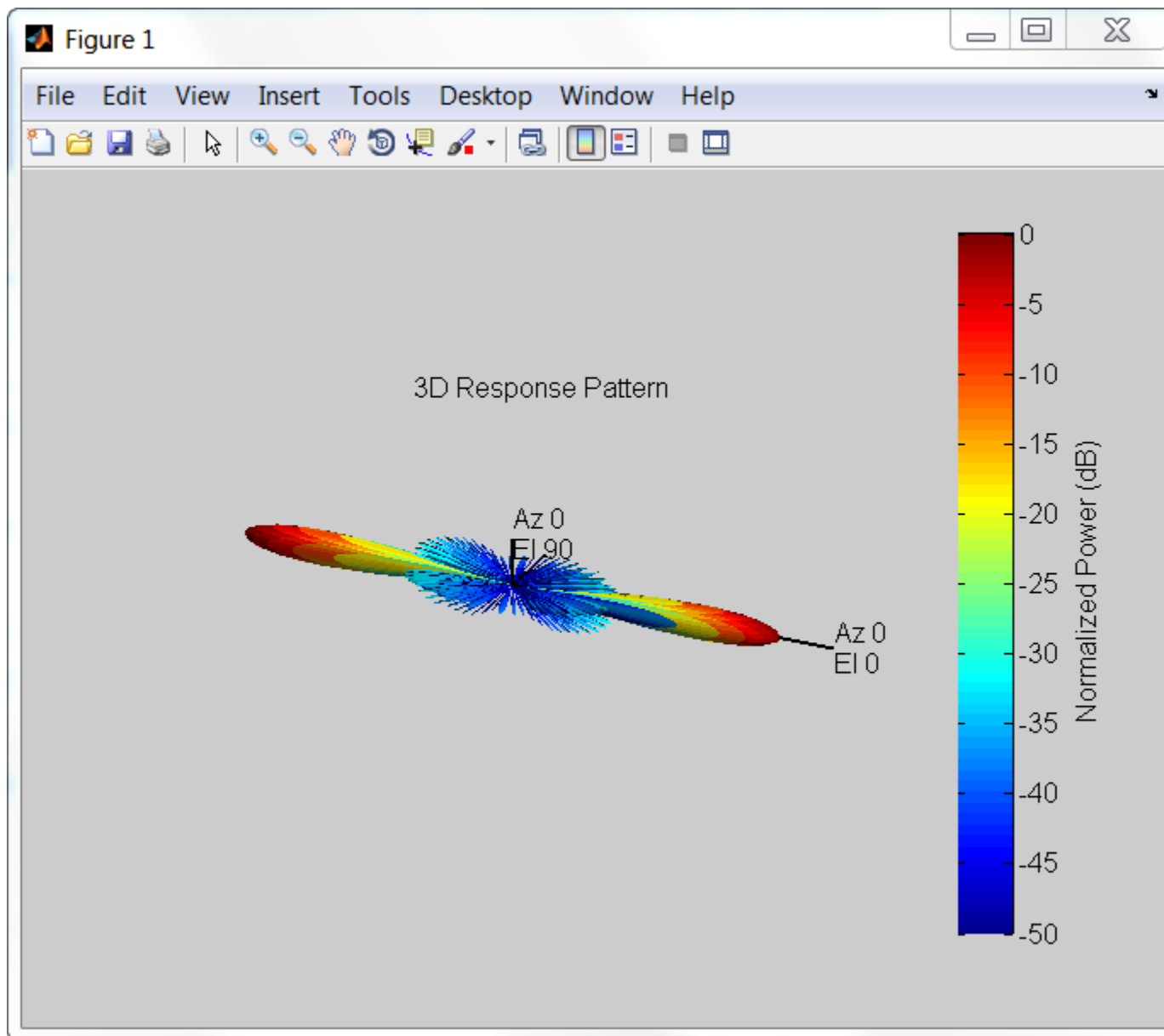

Next, set the properties of the radar platform in the `phased.Platform System` object. The radar is assumed to be stationary and positioned at the origin of the global coordinate system. Set the `Velocity` property to `[0,0,0]` and the `InitialPosition` property to `[0,0,0]`. Set the `OrientationAxes` property to the identity matrix to align the radar platform coordinate axes with the global coordinate system.

```
radarPlatformAxes = [1 0 0;0 1 0;0 0 1];
sRadarPlatform = phased.Platform('InitialPosition',[0;0;0],...
    'Velocity',[0;0;0],...
    'OrientationAxes',radarPlatformAxes);
```

In a radar system, the signal propagates in the form of an electromagnetic wave. The signal is radiated and collected by the antennas used in the radar system. Associate the array with a radiator `phased.Radiator System` object and two collector `phased.Collector System` objects. Set the `WeightsInputPort` property of the radiator to `true` to enable dynamic steering of the transmitted signal at each call of the radiator's `step` method. Creating the two collectors allows for collection of both horizontal and vertical polarization components.

```
sRadiator = phased.Radiator(...
    'Sensor',sArray,...
    'OperatingFrequency',fc,...
    'PropagationSpeed',c,...
    'CombineRadiatedSignals',true,...
    'EnablePolarization',true,...
    'WeightsInputPort',true);
sCollector = phased.Collector(...
    'Sensor',sArray,...
    'OperatingFrequency',fc,...
    'PropagationSpeed',c,...
    'Wavefront','Plane',...
    'EnablePolarization',true,...
    'WeightsInputPort',false);
sCollector2 = phased.Collector(...
    'Sensor',sArray,...
    'OperatingFrequency',fc,...
    'PropagationSpeed',c,...
    'Wavefront','Plane',...
    'EnablePolarization',true,...
```



```
'WeightsInputPort',false);
```

Estimate the peak power used in the `phased.Transmitter` System object to calculate the desired radiated power levels. The transmitted peak power is the power required to achieve a minimum-detection SNR, `snr_min`. You can determine the minimum SNR from the probability of detection, `pd`, and the probability of false alarm, `pfa`, using the `albersheim` function. Then, compute the peak power from the radar equation using the `radareqpow` function. Among the inputs to this function are the overall signal gain, which is the sum of the transmitting element gain, `TransmitterGain` and the array gain, `AG`. Another input is the maximum detection range, `rangegate`. Finally, you need to supply a target cross-section value, `tgt_rcs`. A scalar radar cross section is used in this code section as an approximation even though the full polarization computation later uses a 2-by-2 radar cross section scattering matrix.

```
snr_min = albersheim(pd, pfa, numpulses);
AG = 10*log10(numCols*numRows);
tgt_rcs = 1; % Required target radar cross section
TransmitterGain = 20;
% Compute peak power per element
peak_power = radareqpow(lambda,rangegate,snr_min,...
    sWav.PulseWidth,...
    'RCS',tgt_rcs,...
    'Gain',TransmitterGain + AG);
% Create a transmitter object
sTX = phased.Transmitter(...
    'PeakPower',peak_power,...
    'Gain',TransmitterGain,...
    'LossFactor',0,...
    'InUseOutputPort',true,...
    'CoherentOnTransmit',true);
```

Create a rotating target object and a moving target platform. The rotating target is represented later as an angle-dependent scattering matrix.

```
targetSpeed = 1000; % m/s
targetVec = [-1;1;0]/sqrt(2);
sTarget = phased.RadarTarget(...
    'EnablePolarization',true,...
    'Mode','Monostatic',...
    'ScatteringMatrixSource','Input port',...
```

```

    'OperatingFrequency',fc);
targetPlatformAxes = [1 0 0;0 1 0;0 0 1];
targetRotRate = 45; % degrees per sec
sTargetPlatform = phased.Platform(...
    'InitialPosition',[3500.0; 0; 0],...
    'Velocity', targetSpeed*targetVec,...
    'OrientationAxes',targetPlatformAxes);

```

Set up the following System objects

- a steering vector using `phased.SteeringVector` System object
- a beamformer using `phased.PhaseShiftBeamformer` System object. The `DirectionSource` property is set to 'Input Port' to enable the beamformer to always points towards the known target direction at each call to its `step` method.
- a free-space propagator using `phased.FreeSpace` System object
- a receiver preamp model using `phased.ReceiverPreamp` System object.

```

sSV = phased.SteeringVector('SensorArray',sArray,...
    'PropagationSpeed',c,...
    'IncludeElementResponse',false);
% Create the receiving beamformer
sBF = phased.PhaseShiftBeamformer('SensorArray',sArray,...
    'OperatingFrequency',fc,'PropagationSpeed',c,...
    'DirectionSource','Input port');
% Define free space propagation channel
sFS = phased.FreeSpace(...
    'SampleRate',fs,...
    'TwoWayPropagation',true,...
    'OperatingFrequency',fc);
% Define a receiver with receiver noise
sRX = phased.ReceiverPreamp('Gain',20,...
    'LossFactor',0,...
    'NoiseBandwidth',pulse_bw,...
    'NoiseFigure',1,...
    'ReferenceTemperature',290,...
    'SampleRate',fs,...
    'EnableInputPort',true,...
    'PhaseNoiseInputPort',false,...

```

```
'SeedSource', 'Auto');
```

Allocate MATLAB arrays to store the processing results for later plotting.

```
sig_max_V = zeros(1,numpulses);
sig_max_H = zeros(1,numpulses);
tm_V = zeros(1,numpulses);
tm_H = zeros(1,numpulses);
```

After all the System objects are created, loop over the number of pulses to create the reflected signals. Perform all the processing by invoking the step method for each System object.

```
maxsamp = ceil(tmax*fs);
fast_time_grid = [0:(maxsamp-1)]/fs;
rotangle = 0.0;
for m = 1:numpulses
    x = step(sWav); % Generate pulse
    % Capture only samples within range gated
    x = x(1:maxsamp);
    [s, tx_status] = step(sTX,x); % Create transmitted pulse
    % Move the radar platform and target platform.
    [radarPos,radarVel] = step(sRadarPlatform,1/PRF);
    [targetPos,targetVel] = step(sTargetPlatform,1/PRF);
    % Compute the known target angle
    [targetRng,targetAng] = rangeangle(targetPos,...
        radarPos,...
        radarPlatformAxes);
    % Compute the radar angle with respect to the target axes.
    [radarRng,radarAng] = rangeangle(radarPos,...
        targetPos,...
        targetPlatformAxes);
    % Calculate the steering vector designed to track the target
    sv = step(sSV,fc,targetAng);
    % Radiate the polarized signal toward the target
    tsig1 = step(sRadiator,...
        s,...
        targetAng,...
        radarPlatformAxes,...
        conj(sv));
    % Compute the two-way propagation loss (4*pi*R/lambda)^2
```

```

tsig2 = step(sFS,...
    tsig1,...
    radarPos,...
    targetPos,...
    radarVel,...
    targetVel);
% Create a very simple model of a changing scattering matrix
scatteringMatrix = [cosd(rotangle),0.5*sind(rotangle);...
    0.5*sind(rotangle),cosd(rotangle)];
rsig1 = step(sTarget,...
    tsig2,...
    radarAng,...
    targetPlatformAxes,...
    scatteringMatrix); % Reflect off target
% Collect the vertical component of the radiation.
rsig3V = step(sCollector,...
    rsig1,...
    targetAng,...
    radarPlatformAxes);
% Collect the horizontal component of the radiation. This
% second collector is rotated around the x-axis to be more
% sensitive to horizontal polarization
rsig3H = step(sCollector2,...
    rsig1,...
    targetAng,...
    rotx(90)*radarPlatformAxes);
% Add receiver noise to both sets of signals
rsig4V = step(sRX,rsig3V,~(tx_status>0)); % Receive signal
rsig4H = step(sRX,rsig3H,~(tx_status>0)); % Receive signal
% Beamform the signal
rsigV = step(sBF,rsig4V,targetAng); % Beamforming
rsigH = step(sBF,rsig4H,targetAng); % Beamforming
% Find the maximum returns for each pulse and store them in
% a vector. Store the pulse received time as well.
[sigmaxV,imaxV] = max(abs(rsigV));
[sigmaxH,imaxH] = max(abs(rsigH));
sig_max_V(m) = sigmaxV;
sig_max_H(m) = sigmaxH;
tm_V(m) = fast_time_grid(imaxV) + (m-1)*PRI;
tm_H(m) = fast_time_grid(imaxH) + (m-1)*PRI;

```

```
    % Update the orientation of the target platform axes
    targetPlatformAxes = ...
        rotx(PRI*targetRotRate)*targetPlatformAxes;
    rotangle = rotangle + PRI*targetRotRate;
end
```

Plot the vertical and horizontal polarization for each pulse as a function of time.

```
figure(2);
plot(tm_V,sig_max_V,'. '); hold on;
plot(tm_H,sig_max_H,'r. '); hold off;
xlabel('Time (sec)')
ylabel('Amplitude');
title('Vertical and Horizontal Polarization Components');
legend('Vertical','Horizontal');
grid on;
```

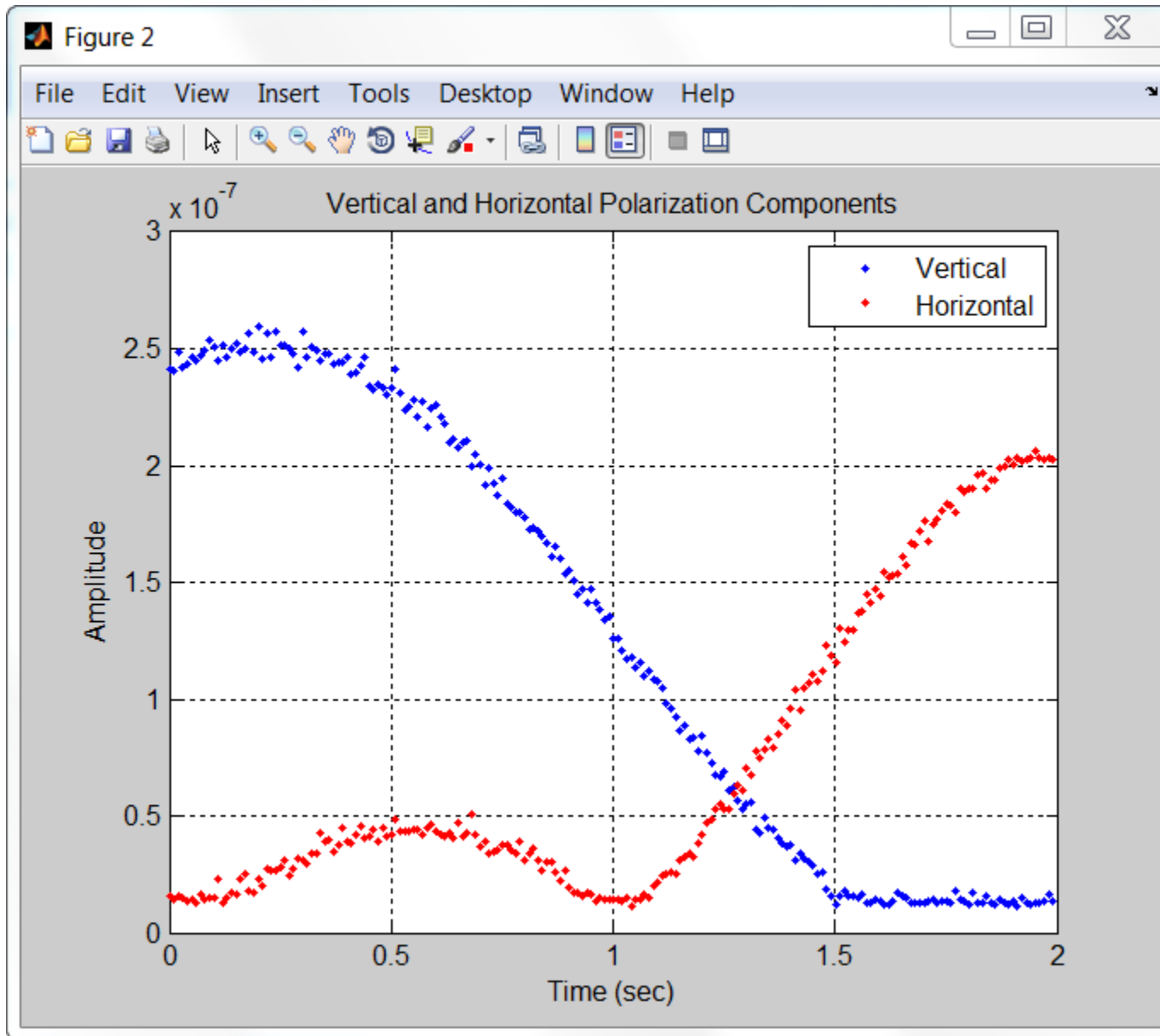

Code Generation

- “About Code Generation” on page 12-2
- “Estimating Directions of Arrival” on page 12-13
- “Making System Objects Persistent” on page 12-16
- “Functions Supported for C/C++ Code Generation” on page 12-19
- “System Objects Supported for C/C++ Code Generation” on page 12-23

About Code Generation

In this section...

“Code Generation Use and Benefits” on page 12-2

“Limitations Specific to Phased Array System Toolbox” on page 12-4

“General Limitations” on page 12-6

“Limitations for System Objects that Require Dynamic Memory Allocation” on page 12-12

Code Generation Use and Benefits

You can use the Phased Array System Toolbox software together with the MATLAB Coder™ product to create C/C++ code that implements your MATLAB functions and models. With this software, you can

- Create a MEX file to speed up your own MATLAB application.
- Generate a stand-alone executable that runs independently of MATLAB on your own computer or another platform.
- Include System objects in the same way as any other element.

In general, the code you generate using the toolbox is portable ANSI® C code. In order to use code generation, you need a MATLAB Coder license. Using Phased Array System Toolbox software requires licenses for both the DSP System Toolbox™ and the Signal Processing Toolbox™. See the “Getting Started with MATLAB Coder” page for more information.

Creating a MATLAB Coder MEX-file can lead to substantial acceleration of your MATLAB algorithms. It is also a convenient first step in a workflow that ultimately leads to completely standalone code. When you create a MEX-file, it runs in the MATLAB environment. Its inputs and outputs are available for inspection just like any other MATLAB variable. You can use MATLAB’s visualization, and other tools, for verification and analysis.

Within your code, you can run specific commands either as generated C code or by running using the MATLAB engine. In cases where an isolated command does not yet have code generation support, you can use the

`coder.extrinsic` command to embed the command in your code. This means that the generated code reenters the MATLAB environment when it needs to run that particular command. This is also useful if you wish to embed certain commands that cannot generate code (such as plotting functions).

The simplest way to generate MEX-files from your MATLAB code is by using the `codegen` function at the command line. Often, generating a MEX-file involves nothing more than invoking the `coder` command on one of your existing functions. For example, if you have an existing function, `myfunction.m`, you can type the commands at the command line to compile and run the MEX function. `codegen` adds a platform-specific extension to this name. In this case, the `_mex` suffix is added.

```
codegen myfunction.m
myfunction_mex;
```

You can generate standalone executables that run independently of the MATLAB environment. You can do this by creating a MATLAB Coder project inside the MATLAB Coder Integrated Development Environment (IDE). Alternatively, you can issue the `codegen` command in the command line environment with appropriate configuration parameters. To create a standalone executable, you must write your own `main.c` or `main.cpp` function. See “C/C++ Code Generation” for more information.

Set Up Your Compiler

Before using `codegen` to compile your code, you must set up your C/C++ compiler. For 32-bit Windows platforms, MathWorks® supplies a default compiler with MATLAB. If your installation does not include a default compiler, you can supply your own compiler. For the current list of supported compilers, see Supported and Compatible Compilers on the MathWorks Web site. Install a compiler that is suitable for your platform. Then, read “Setting Up the C/C++ Compiler”. After installation, at the MATLAB command prompt, run `mex -setup`. You can then use the `codegen` function to compile your code.

Functions and System Objects That Support Code Generation

Almost all Phased Array System Toolbox functions and System objects are supported for code generation. For more information, see “Functions

Supported for C/C++ Code Generation” on page 12-19 and “System Objects Supported for C/C++ Code Generation” on page 12-23.

Limitations Specific to Phased Array System Toolbox

Code Generation has the following limitations when used with the Phased Array System Toolbox software:

- Passing arguments with variable-sized dimensions into any Phased Array System Toolbox function or System object step method is not supported.
- When you employ antennas and arrays that produce polarized fields, the `EnablePolarization` parameter for the `phased.Collector`, `phased.Radiator`, and `phased.WidebandCollector`, `phased.RadarTarget`, `phased.ArrayResponse`, and `phased.SteeringVector` System objects must be set to `true`. This requirement differs from regular MATLAB usage where you can set `EnablePolarization` property to `false` even when polarization is enabled. For example, this code uses a polarized antenna, which requires that `EnablePolarization` property of the `phased.Radiator` System object be set to `true`.

```
function [y] = codegen_radiator()
sSD = phased.ShortDipoleAntennaElement(...
    'FrequencyRange',[100e6,600e6], 'AxisDirection','Y');
c = physconst('LightSpeed');
fc = 200e6;
lambda = c/fc;
d = lambda/2;
sURA = phased.URA('Element',sSD,...
    'Size',[3,3],...
    'ElementSpacing',[d,d]);
sRad = phased.Radiator('Sensor',sURA,...
    'OperatingFrequency',150e6,...
    'CombineRadiatedSignals',true,...
    'EnablePolarization',true);
x = [1;2;1];
radiatingAngle = [10;0]; % One angle for one antenna
y = step(sRad,x,radiatingAngle,eye(3,3));
```

- Visualization methods for Phased Array System Toolbox methods such `plotResponse` and `viewArray` are not supported.

- When a System object contains another System object as a property value, you must set the contained System object in the constructor. You cannot use Object.Property notation to set the property. For example

```
sSD = phased.ShortDipoleAntennaElement(...
    'FrequencyRange',[100e6,600e6],'AxisDirection','Y');
sURA = phased.URA('Element',sSD,...
    'Size',[3,3],...
    'ElementSpacing',[0.75,0.75]);
```

is valid for codegen but

```
sSD = phased.ShortDipoleAntennaElement(...
    'FrequencyRange',[100e6,600e6],'AxisDirection','Y');
sURA = phased.URA('Size',[3,3],...
    'ElementSpacing',[0.75,0.75]);
sURA.Element = sSD;
```

is not.

- A list of the limitations on Phased Array System Toolbox functions and System objects is presented here:

Function or System Object	Limitation
plotResponse	This System object method is not supported.
viewArray	This System object method is not supported.
blakechart	This function is not supported.
polsignature	Supported only when output arguments are specified.
rocpfa	The NonfluctuatingNoncoherent signal type is not supported.
rocsnr	The NonfluctuatingNoncoherent signal type is not supported.

Function or System Object	Limitation
stokes	Supported only when output arguments are specified.
phased.HeterogeneousConformalArray	This System object is not supported.
phased.HeterogeneousULA	This System object is not supported.
phased.HeterogeneousURA	This System object is not supported.
phased.ArrayGain	This System object cannot be used with arrays containing polarized antenna elements, that is, <code>phased.ShortDipoleAntennaElement</code> or <code>phased.CrossedDipoleAntennaElement</code>
phased.MatchedFilter	The <code>CustomSpectrumWindow</code> property is not supported.
phased.RangeDopplerResponse	The <code>CustomRangeWindow</code> and the <code>CustomDopplerWindow</code> properties are not supported.

General Limitations

Code Generation has some general limitations not specifically related to the Phased Array System Toolbox software. For a more complete discussion, see “System Objects in MATLAB Code Generation”.

- You cannot use cell arrays in your code.
- The data type and complexity (i.e., real or complex) of any input argument to a function or System object must always remain the same.
- You can assign a nontunable System object property value only once before a `step` method is executed. This requirement differs from MATLAB usage where you can initialize these properties multiple times before the `step` method is executed.

This example sets the `Size` property twice.

```
function codegen_property
sSD = phased.ShortDipoleAntennaElement(...
```

```

        'FrequencyRange',[0.9e8,2e9], 'AxisDirection','Y');
sURA = phased.URA('Element',sSD,...
    'Size',[3,3],...
    'ElementSpacing',[0.15,0.15]);
sURA.Size = [4,4];

```

When you issue the command

```
codegen codegen_property
```

the following error message is produced: "A nontunable property may only be assigned once."

- You cannot pass a System object to any method or function that you made extrinsic using `coder.extrinsic`.
- You cannot load a MAT-file using `coder.load` when it contains a System object. For example, if you construct a System object in the MATLAB environment and save it to a MAT-file

```

sSD = phased.ShortDipoleAntennaElement(...
    'FrequencyRange',[0.9e8,2e9], 'AxisDirection','Y');
save x.mat sSD;
clear sSD;

```

then you cannot load the System object in your compiled MEX-file:

```

function codegen_load1()
W = coder.load('x.mat');
sSD = W.sSD;

```

The compilation

```
codegen codegen_load1
```

will produced an error message: `Found unsupported class for variable using function 'coder.load'. MATLAB class 'phased.ShortDipoleAntennaElement' found at 'W.sSD' is unsupported.'

To avoid this problem, you can save the object's properties to a MAT-file, then, use `coder.load` to load the object properties and re-create the object.

For example, create and save a System object's properties in the MATLAB environment

```
sSD = phased.ShortDipoleAntennaElement(...
    'FrequencyRange',[0.9e8,2e9],'AxisDirection','Y');
FrequencyRange = sSD.FrequencyRange;
AxisDirection = sSD.AxisDirection;
save x.mat FrequencyRange AxisDirection;
```

Then, write a function `codegen_load2` to load the properties and create a System object.

```
function codegen_load2()
W = coder.load('x.mat');
sSD = phased.ShortDipoleAntennaElement(...
    'FrequencyRange',W.FrequencyRange,...
    'AxisDirection',W.AxisDirection);
```

Then, issue the commands to create and execute the MEX-file, `codegen_load2_mex`.

```
codegen codegen_load2;
codegen_load2_mex
```

- Nontunable properties must be constant. A *constant* is a value that can be evaluated at compile-time. System objects properties are either tunable or nontunable. You can change tunable properties even if the object is locked. Unless otherwise specified, System object properties are nontunable. Refer to the object's reference page to determine whether an individual property is tunable or not. If you try to set a nontunable System object property and the compiler determines that it is not constant, you will get an error. For example, the `phased.URA` System object has a nontunable property, `ElementSpacing`, which sets the distance between elements. You may want to create an array that is tuned to a frequency. You cannot pass in the frequency as an input argument because the frequency must be a constant.

```
function [resp] = codegen_const1(fc)
sSD = phased.ShortDipoleAntennaElement(...
    'FrequencyRange',[100e6,600e6],'AxisDirection','Y');
c = physconst('LightSpeed');
lambda = c/fc;
```

```

d = lambda/2;
sURA = phased.URA('Element',sSD,...
    'Size',[3,3],...
    'ElementSpacing',[d,d]);
ang = [30;0];
resp = step(sURA,fc,ang);

```

When you codegen this function

```

fc = 200e6;
codegen codegen_const1 -args {fc}

```

the compiler responds that the value of the 'ElementSpacing' property, *d*, is not constant and generates the error message: "Failed to compute constant value for nontunable property 'ElementSpacing'. In code generation, nontunable properties can only be assigned constant values." It is not constant because it depends upon a non-constant variable, *fc*.

To correct this problem, set *fc* to a constant within the function:

```

function [resp] = codegen_const2()
sSD = phased.ShortDipoleAntennaElement(...
    'FrequencyRange',[100e6,600e6], 'AxisDirection','Y');
c = physconst('LightSpeed');
fc = 200e6;
lambda = c/fc;
d = lambda/2;
sURA = phased.URA('Element',sSD,...
    'Size',[3,3],...
    'ElementSpacing',[d,d]);
ang = [30;0];
resp = step(sURA,fc,ang);

```

and then compile

```

codegen codegen_const2

```

- In certain cases, the compiler cannot determine the values of nontunable properties at compile time or the code may not even compile. Consider the following example that reads in the *x,y,z*-coordinates of a 5-element array

from a file and then, creates a conformal array System object. The text file, `elempos.txt`, contains the element coordinates

```
-0.5000 -0.2588 0          0.2588  0.5000
-0.8660 -0.9659 -1.0000 -0.9659 -0.8660
0         0         0         0         0
```

The file `collectWave.m` contains reads the element coordinates and creates the object.

```
function y = collectWave(angle)
    elPos = calcElPos;
    cArr = phased.ConformalArray('ElementPosition',elPos);
    y = collectPlaneWave(cArr,randn(4,2),angle,1e8);
end
```

```
function elPos = calcElPos
    fid = fopen('elempos.txt','r');
    el = textscan(fid, '%f');
    n = length(el{1});
    nelem = n/3;
    fclose(fid);
    elPos = reshape(el{1},nelem,3).';
end
```

Attempting to compile

```
codegen collectWave -args {[10 30]}
```

produces the error "Permissions 'r' and 'r+' are not supported".

The following example is a work-around that uses `coder.extrinsic` and `coder.const` to insure that the value for the nontunable property, 'ElementPosition', is a compile time constant. The function in the file, `collectWave1.m`, creates the object using the `calcElPos` function. This function runs inside the MATLAB interpreter at compile time.

```
function y = collectWave1(angle)
    coder.extrinsic('calcElPos')
    elPos = coder.const(calcElPos);
    cArr = phased.ConformalArray('ElementPosition',elPos);
    y = collectPlaneWave(cArr,randn(4,2),angle,1e8);
```



```
end
```

The file `calcElPos.m` loads the element positions from the text file

```
function elPos = calcElPos
fid = fopen('elempos.txt','r');
el = textscan(fid, '%f');
n = length(el{1});
nelem = n/3;
fclose(fid);
elPos = reshape(el{1},nelem,3).';
```

Only the `collectWave1.m` file is compiled with `codegen`. Compiling and running

```
codegen collectWave1 -args {[10 30]}
collectWave1_mex([10,30])
```

will succeed.

An alternate work-around uses `coder.load` to insure that the value of the nontunable property 'ElementPosition' is compile-time constant. In the MATLAB environment, run `calcElPos2` to save the array coordinates contained in `elempos.txt` to a MAT-file. Then, load the contents of the MAT-file within the compiled code.

```
function calcElPos2
fid = fopen('elempos.txt');
el = textscan(fid, '%f');
fclose(fid);
elPos = reshape(el{1},[],3).';
save('positions', 'elPos');
end
```

The file `collectWave2.m` loads the coordinate positions and creates the conformal array object

```
function y = collectWave2(angle)
var = coder.load('positions');
cArr = phased.ConformalArray('ElementPosition',var.elPos);
y = collectPlaneWave(cArr,randn(4,2),angle,1e8);
end
```

Only the `collectWave2.m` file is compiled with `codegen`. Compiling and running `collectWave2.m`

```
codegen collectWave2 -args {[10 30]}
collectWave2_mex([10,30])
```

will succeed. This second approach is more general than the first since a MAT-file can contain any variables, except System objects.

- The System object `clone` method is not supported.

Limitations for System Objects that Require Dynamic Memory Allocation

System objects that require dynamic memory allocation cannot be used for code generation in the following cases:

Inside a MATLAB Function block in a Simulink® model.
Inside a MATLAB function in a Stateflow® chart.
When using MATLAB as the action language in a Stateflow chart.
Inside a Truth Table block in a Simulink model.
Inside a MATLAB System block (except for normal mode).
When using Simulink Coder for code generation.
When using MATLAB Coder for code generation and dynamic memory allocation is disabled.

Estimating Directions of Arrival

Compile, using codegen, the function EstimateDOA.m. This function estimates the directions-of-arrival (DOA's) of two signals with added noise that are received by a standard 10-element Uniform Line Array (ULA). The antenna operating frequency is 150 MHz and the array elements are spaced one-half wavelength apart. The actual direction of arrival of the first signal is 10° azimuth, 20° elevation. The direction of arrival of the second signal is 45° azimuth, 60° elevation. Signals and noise are generated using the sensorsig function.

```
function [az] = EstimateDOA()
% Example:
% Estimate the DOAs of two signals received by a standard
% 10-element ULA with element spacing one half-wavelength apart.
% The antenna operating frequency is 150 MHz.
% The actual direction of the first signal is 10 degrees in
% azimuth and 20 degrees in elevation. The direction of the
% second signal is 45 degrees in azimuth and 60 degrees in
% elevation.
c = physconst('LightSpeed');
fc = 150e6;
lambda = c/fc;
fs = 8000;
nsamp = 8000;
sigma = 0.1;
ang = [10 20; 45 60]';
sIso = phased.IsotropicAntennaElement('FrequencyRange',[100e6,300e6]);
sULA = phased.ULA('Element',sIso,'NumElements',10,'ElementSpacing',lambda/2);
pos = getElementPosition(sULA)/lambda;
sig = sensorsig(pos,nsamp,ang,sigma^2);
sDOA = phased.RootMUSICEstimator('SensorArray',sULA,...
    'OperatingFrequency',fc,...
    'NumSignalsSource','Property','NumSignals',2);
doas = step(sDOA,sig);
az = broadside2az(sort(doas),[20,60]);
end
```

Run codegen at the command line to generate the mex function, EstimateDOA_mex, and then run the mex function:

```
codegen EstimateDOA.m
EstimateDOA_mex
```

The estimated arrival angles are:

```
az =

    10.0036    45.0030
```

The program contains a fixed value for the noise variance. If you wanted to reuse the same code for different noise levels, you can pass the noise variance as an argument into the function. This is done in the function `EstimateDOA1.m`, shown here, which has the input argument `sigma`.

```
function [az] = EstimateDOA1(sigma)
% Example:
% Estimate the DOAs of two signals received by a standard
% 10-element ULA with element spacing one half-wavelength apart.
% The antenna operating frequency is 150 MHz.
% The actual direction of the first signal is 10 degrees in
% azimuth and 20 degrees in elevation. The direction of the
% second signal is 45 degrees in azimuth and 60 degrees in
% elevation.
c = physconst('LightSpeed');
fc = 150e6;
lambda = c/fc;
fs = 8000;
nsamp = 8000;
ang = [10 20; 45 60]';
sIso = phased.IsotropicAntennaElement('FrequencyRange',[100e6,300e6]);
sULA = phased.ULA('Element',sIso,'NumElements',10,'ElementSpacing',lambda/2);
pos = getElementPosition(sULA)/lambda;
sig = sensorsig(pos,nsamp,ang,sigma^2);
sDOA = phased.RootMUSICEstimator('SensorArray',sULA,...
    'OperatingFrequency',fc,...
    'NumSignalsSource','Property','NumSignals',2);
doas = step(sDOA,sig);
az = broadside2az(sort(doas),[20,60]);
```

Run `codegen` at the command line to generate the mex function, `EstimateDOA1_mex`, using the `-args` option to specify the type of input argument. Then run the mex function with several different input parameters:

```
codegen EstimateDOA1.m -args {1}
EstimateDOA1_mex(1)
az =
    10.0130    45.0613
EstimateDOA1_mex(10)
az =
    10.1882    44.3327
EstimateDOA1_mex(15)
az =
     8.1620    46.2440
```

Increasing the value of `sigma` degrades the estimates of the azimuth angles.

Making System Objects Persistent

Sometimes, it is convenient to put System objects inside a function that is to be called many times. This eliminates the overhead in creating new instances of a System object each time the function is called. You can write logic which creates the System object just once and declares it to be `persistent`. For example, suppose you require the response of an 11-element ULA for several different arrival angles and want to plot that response versus angle.

```
function plot_ULA_response
azangles = [-90:90];
elangles = zeros(size(azangles));
fc = 100e9;
c = physconst('LightSpeed');
N = size(azangles,2);
lambda = c/fc;
d = 0.4*lambda;
numelements = 11;
resp = zeros(1,N);
sIso = phased.IsotropicAntennaElement(...
    'FrequencyRange',[1,200]*1e9,...
    'BackBaffled',false);
sULA = phased.ULA('Element',sIso,...
    'NumElements',numelements,...
    'ElementSpacing',d,...
    'Taper',taylorwin(numelements).');
for n = 1:N
    x = get_ULA_response(sULA,fc,azangles(n),elangles(n));
    resp(n) = abs(x);
end
plot(azangles,20*log10(resp));
title('ULA Response');
xlabel('Angle (deg)');
ylabel('Response (db)');
grid;
end

function resp = get_ULA_response(sULA,fc,az,el)
persistent sAR;
c = physconst('LightSpeed');
```

```
if isempty(sAR)
    sAR = phased.ArrayResponse('SensorArray',sULA,...
        'PropagationSpeed',c,...
        'WeightsInputPort',false,...
        'EnablePolarization',false);
end
resp = step(sAR,fc,[az;el]);
end
```

To create the code, run `codegen` to create the mex-file `plot_ULA_response_mex`, and execute the mex-file at the command line:

```
codegen plot_ULA_response
plot_ULA_response_mex;
```

which yields the plot

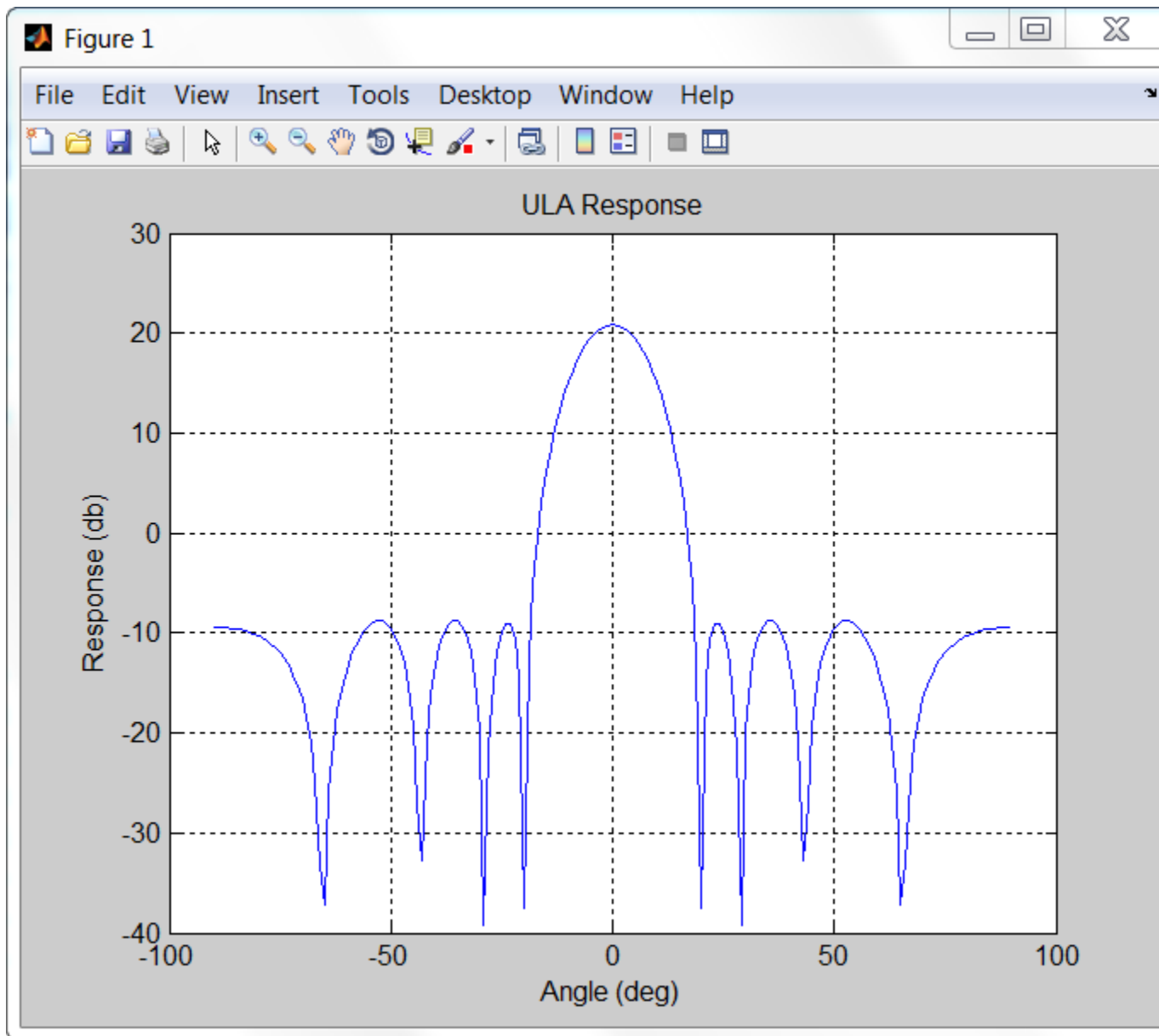

Functions Supported for C/C++ Code Generation

Function	Description
aictest	Dimension of signal subspace
albersheim	Required SNR using Albersheim's equation
ambgfun	Ambiguity function
aperture2gain	Convert effective aperture to gain
az2broadside	Convert azimuth angle to broadside angle
azel2phitheta	Convert angles from azimuth/elevation form to phi/theta form
azel2phithetapat	Convert radiation pattern from azimuth/elevation to phi/theta form
azel2uv	Convert azimuth/elevation angles to u/v coordinates
azel2uvpat	Convert radiation pattern from azimuth/elevation form to u/v form
azelaxes	Spherical basis vectors in 3-by-3 matrix form
beat2range	Convert beat frequency to range
billingsleyicm	Billingsley's intrinsic clutter motion (ICM) model
broadside2az	Convert broadside angle to azimuth angle
cart2sphvec	Convert vector from Cartesian components to spherical representation
cbfweights	Conventional beamformer weights
circpol2pol	Convert circular component representation of field to linear component representation
dechirp	Perform dechirp operation on FMCW signal
delayseq	Delay or advance sequence
depressionang	Depression angle of surface target
dop2speed	Convert Doppler shift to speed
dopsteeringvec	Doppler steering vector
effearthradius	Effective earth radius
espritdoa	Direction of arrival using TLS ESPRIT
fsp1	Free space path loss

Function	Description
gain2aperture	Convert gain to effective aperture
global2localcoord	Convert global to local coordinates
grazingang	Grazing angle of surface target
horizonrange	Horizon range
lcmvweights	Narrowband linearly constrained minimum variance (LCMV) beamformer weights
local2globalcoord	Convert local to global coordinates
mdltest	Dimension of signal subspace
mvdrweights	Minimum variance distortionless response (MVDR) beamformer weights
noisepow	Receiver noise power
npwgnthresh	Detection SNR threshold for signal in white Gaussian noise
phitheta2azel	Convert angles from phi/theta form to azimuth/elevation form
phitheta2azelpat	Convert radiation pattern from phi/theta form to azimuth/elevation form
phitheta2uv	Convert phi/theta angles to u/v coordinates
phitheta2uvpat	Convert radiation pattern from phi/theta form to u/v form
physconst	Physical constants
pol2circpol	Convert linear component representation of field to circular component representation
polellip	Parameters of ellipse traced out by tip of a polarized field vector
polloss	Polarization loss
polratio	Ratio of vertical to horizontal linear polarization components of a field
polsignature	Copolarization and cross-polarization signatures
pulsint	Pulse integration
radareqpow	Peak power estimate from radar equation
radareqrng	Maximum theoretical range estimate

Function	Description
radareqsnr	SNR estimate from radar equation
radarvcd	Vertical coverage diagram
radialspeed	Relative radial speed
range2beat	Convert range to beat frequency
range2bw	Convert range resolution to required bandwidth
range2time	Convert propagation distance to propagation time
rangeangle	Range and angle calculation
rdcoupling	Range Doppler coupling
rocpfa	Receiver operating characteristic curves by false-alarm probability
rocsnr	Receiver operating characteristic curves by SNR
rootmusicdoa	Direction of arrival using Root MUSIC
rotx	Rotation matrix for rotations around x-axis
roty	Rotation matrix for rotations around y-axis
rotz	Rotation matrix for rotations around z-axis
sensorcov	Sensor spatial covariance matrix
sensorsig	Simulate received signal at sensor array
shnidman	Required SNR using Shnidman's equation
speed2dop	Convert speed to Doppler shift
sph2cartvec	Convert vector from spherical basis components to Cartesian components
spsmooth	Spatial smoothing
steervec	Steering vector
stokes	Stokes parameters of polarized field
stretchfreq2rng	Convert frequency offset to range
surfacegamma	Gamma value for different terrains
surfclutterrcs	Surface clutter radar cross section (RCS)
systemp	Receiver system-noise temperature

Function	Description
time2range	Convert propagation time to propagation distance
unigrid	Uniform grid
uv2azel	Convert u/v coordinates to azimuth/elevation angles
uv2azelpat	Convert radiation pattern from u/v form to azimuth/elevation form
uv2phitheta	Convert u/v coordinates to phi/theta angles
uv2phithetapat	Convert radiation pattern from u/v form to phi/theta form
val2ind	Uniform grid index

System Objects Supported for C/C++ Code Generation

Supported Phased Array System Toolbox System Objects

Object	Description
Antenna and Microphone Elements	
phased.CosineAntennaElement	Cosine antenna element
phased.CrossedDipoleAntennaElement	Crossed-dipole antenna element
phased.CustomAntennaElement	Custom antenna element
phased.CustomMicrophoneElement	Custom microphone
phased.IsotropicAntennaElement	Isotropic antenna element
phased.OmnidirectionalMicrophoneElement	Omnidirectional microphone
phased.ShortDipoleAntennaElement	Short-dipole antenna element
Array Geometries and Analysis	
phased.ULA	Uniform linear array
phased.URA	Uniform rectangular array
phased.ConformalArray	Conformal array
phased.PartitionedArray	Phased array partitioned into subarrays
phased.ReplicatedSubarray	Phased array formed by replicated subarrays
phased.SteeringVector	Sensor array steering vector
phased.ArrayGain	Sensor array gain
phased.ArrayResponse	Sensor array response
phased.ElementDelay	Sensor array element delay estimator
Signal Radiation and Collection	
phased.Collector	Narrowband signal collector
phased.Radiator	Narrowband signal radiator
phased.WidebandCollector	Wideband signal collector
Waveforms, Transmitter, and Receiver	

Supported Phased Array System Toolbox System Objects (Continued)

Object	Description
phased.LinearFMWaveform	Linear FM pulse waveform
phased.PhaseCodedWaveform	Phase-coded pulse waveform
phased.RectangularWaveform	Rectangular pulse waveform
phased.SteppedFMWaveform	Stepped FM pulse waveform
phased.FMCWWaveform	FMCW Waveform
phased.MatchedFilter	Matched filter
phased.Transmitter	Transmitter
phased.ReceiverPreamp	Receiver preamp
Beamforming	
phased.PhaseShiftBeamformer	Narrowband phase shift beamformer
phased.LCMVBeamformer	Narrowband LCMV beamformer
phased.MVDRBeamformer	Narrowband MVDR (Capon) beamformer
phased.SubbandPhaseShiftBeamformer	Subband phase shift beamformer
phased.FrostBeamformer	Frost beamformer
phased.TimeDelayBeamformer	Time delay beamformer
phased.TimeDelayLCMVBeamformer	Time delay LCMV beamformer
phased.SteeringVector	Sensor array steering vector
Direction of Arrival (DOA) Estimation	
phased.SumDifferenceMonopulseTracker2D	Sum and difference monopulse for ULA
phased.SumDifferenceMonopulseTracker3D	Sum and difference monopulse for URA
phased.BeamscanEstimator	Beamscan spatial spectrum estimator for ULA
phased.BeamscanEstimator2D	2-D beamscan spatial spectrum estimator
phased.MVDREstimator	MVDR (Capon) spatial spectrum estimator for ULA
phased.MVDREstimator2D	2-D MVDR (Capon) spatial spectrum estimator
phased.RootMUSICEstimator	Root MUSIC direction of arrival (DOA) estimator

Supported Phased Array System Toolbox System Objects (Continued)

Object	Description
phased.RootWSFEstimator	Root WSF direction of arrival (DOA) estimator
phased.ESPRITEstimator	ESPRIT direction of arrival (DOA) estimator
phased.BeamspaceESPRITEstimator	Beamspace ESPRIT direction of arrival (DOA) estimator
Space-Time Adaptive Processing (STAP)	
phased.STAPSMIBeamformer	Sample matrix inversion (SMI) beamformer
phased.DPCACanceller	Displaced phase center array (DPCA) pulse canceller
phased.ADPCACanceller	Adaptive DPCA (ADPCA) pulse canceller
phased.AngleDopplerResponse	Angle-Doppler response
Detection	
phased.CFARDetector	Constant false alarm rate (CFAR) detector
phased.MatchedFilter	Matched filter
phased.RangeDopplerResponse	Range-Doppler response
phased.StretchProcessor	Stretch processor for linear FM waveform
phased.TimeVaryingGain	Time varying gain control
Environment and Target Models	
phased.FreeSpace	Free space environment
phased.RadarTarget	Radar target
phased.ConstantGammaClutter	Constant gamma clutter simulation
phased.BarrageJammer	Barrage jammer
Coordinate Systems and Motion Modeling	
phased.Platform	Motion platform

Define New System Objects

- “Define Basic System Objects” on page 13-2
- “Change Number of Step Inputs or Outputs” on page 13-4
- “Validate Property and Input Values” on page 13-7
- “Initialize Properties and Setup One-Time Calculations” on page 13-10
- “Set Property Values at Construction Time” on page 13-13
- “Reset Algorithm State” on page 13-16
- “Define Property Attributes” on page 13-18
- “Hide Inactive Properties” on page 13-22
- “Limit Property Values to Finite String Set” on page 13-24
- “Process Tuned Properties” on page 13-27
- “Release System Object Resources” on page 13-29
- “Define Composite System Objects” on page 13-31
- “Define Finite Source Objects” on page 13-35
- “Save System Object” on page 13-37
- “Load System Object” on page 13-40
- “Clone System Object” on page 13-43
- “Methods Timing” on page 13-44
- “System Object Input Arguments and ~ in Code Examples” on page 13-47
- “What Are Mixin Classes?” on page 13-48

Define Basic System Objects

This example shows how to create a basic System object that increments a number by one.

The class definition file contains the minimum elements required to define a System object.

Create the Class Definition File

- 1 Create a MATLAB file named `AddOne.m` to contain the definition of your System object.

```
edit AddOne.m
```

- 2 Subclass your object from `matlab.System`. Insert this line as the first line of your file.

```
classdef AddOne < matlab.System
```

- 3 Add the `stepImpl` method, which contains the algorithm that runs when users call the `step` method on your object. You always set the `stepImpl` method access to `protected` because it is an internal method that users do not directly call or run.

All methods, except static methods, expect the System object handle as the first input argument. You can use any name for your System object handle.

In this example, instead of passing in the object handle, `~` is used to indicate that the object handle is not used in the function. Using `~` instead of an object handle prevents warnings about unused variables from occurring.

By default, the number of inputs and outputs are both one. To change the number of inputs or outputs, use the `getNumInputsImpl` or `getNumOutputsImpl` method, respectively.

```
methods (Access=protected)
    function y = stepImpl(~, x)
        y = x + 1;
    end
end
```

Note Instead of manually creating your class definition file, you can use **File > New > System Object** to open a sample System object file in the editor. You then can edit that file, using it as guideline, to create your own System object.

Complete Class Definition File for Basic System Object

```
classdef AddOne < matlab.System
%ADDONE Compute an output value one greater than the input value

    % All methods occur inside a methods declaration.
    % The stepImpl method has protected access
    methods (Access=protected)

        function y = stepImpl(~,x)
            y = x + 1;
        end
    end
end
```

See Also

[stepImpl](#) | [getNumInputsImpl](#) | [getNumOutputsImpl](#) | [matlab.System](#) |

Related Examples

- “Change Number of Step Inputs or Outputs” on page 13-4

Concepts

- “System Design and Simulation in MATLAB”

Change Number of Step Inputs or Outputs

This example shows how to specify two inputs and two outputs for the `step` method.

If you do not specify the `getNumInputsImpl` and `getNumOutputsImpl` methods, the object uses the default values of 1 input and 1 output. In this case, the user must provide an input to the `step` method.

Note You should only use `getNumInputsImpl` or `getNumOutputsImpl` methods to change the number of System object inputs or outputs. Do not use any other handle objects within a System object to change the number of inputs or outputs.

To specify no inputs, you must explicitly set the number of inputs to 0 using the `getNumInputsImpl` method. To specify no outputs, you must explicitly return 0 in the `getNumOutputsImpl` method.

You always set the `getNumInputsImpl` and `getNumOutputsImpl` methods access to `protected` because they are internal methods that users do not directly call or run.

Update the Algorithm for Multiple Inputs and Outputs

Update the `stepImpl` method to accept a second input and provide a second output.

```
methods (Access=protected)
    function [y1,y2] = stepImpl(~,x1,x2)
        y1 = x1 + 1;
        y2 = x2 + 1;
    end
end
```

Update the Associated Methods

Use `getNumInputsImpl` and `getNumOutputsImpl` to specify two inputs and two outputs, respectively.

```

methods (Access=protected)
    function numIn = getNumInputsImpl(~)
        numIn = 2;
    end

    function numOut = getNumOutputsImpl(~)
        numOut = 2;
    end
end

```

Complete Class Definition File with Multiple Inputs and Outputs

```

classdef AddOne < matlab.System
%ADDONE Compute output values two greater than the input values

    % All methods occur inside a methods declaration.
    % The stepImpl method has protected access
    methods(Access=protected)

        function [y1,y2] = stepImpl(~,x1,x2)
            y1 = x1 + 1;
            y2 = x2 + 1;
        end

        % getNumInputsImpl method calculates number of inputs
        function num = getNumInputsImpl(~)
            num = 2;
        end

        % getNumOutputsImpl method calculates number of outputs
        function num = getNumOutputsImpl(~)
            num = 2;
        end
    end
end

```

See Also

[getNumInputsImpl](#) | [getNumOutputsImpl](#) |

Related Examples

- “Validate Property and Input Values” on page 13-7
- “Define Basic System Objects” on page 13-2

Concepts

- “System Object Input Arguments and ~ in Code Examples” on page 13-47

Validate Property and Input Values

This example shows how to verify that the user's inputs and property values are valid.

Validate Properties

This example shows how to validate the value of a single property using `set.PropertyName` syntax. In this case, the *PropertyName* is `Increment`.

```
methods
    % Validate the properties of the object
    function set.Increment(obj,val)
        if val >= 10
            error('The increment value must be less than 10');
        end
        obj.Increment = val;
    end
end
```

This example shows how to validate the value of two interdependent properties using the `validatePropertiesImpl` method. In this case, the `UseIncrement` property value must be true and the `WrapValue` property value must be less than the `Increment` property value.

```
methods (Access=protected)
    function validatePropertiesImpl(obj)
        if obj.UseIncrement && obj.WrapValue < obj.Increment
            error('Wrap value must be less than increment value');
        end
    end
end
```

Validate Inputs

This example shows how to validate that the first input is a numeric value.

```
methods (Access=protected)
    function validateInputsImpl(~,x)
        if ~isnumeric(x)
```

```
        error('Input must be numeric');
    end
end
end
```

Complete Class Definition File with Property and Input Validation

```
classdef AddOne < matlab.System
%ADDONE Compute an output value by incrementing the input value

% All properties occur inside a properties declaration.
% These properties have public access (the default)
properties (Logical)
    UseIncrement = true
end

properties (PositiveInteger)
    Increment = 1
    WrapValue = 10
end

methods
    % Validate the properties of the object
    function set.Increment(obj, val)
        if val >= 10
            error('The increment value must be less than 10');
        end
        obj.Increment = val;
    end
end

methods (Access=protected)
    function validatePropertiesImpl(obj)
        if obj.UseIncrement && obj.WrapValue < obj.Increment
            error('Wrap value must be less than increment value');
        end
    end

    % Validate the inputs to the object
    function validateInputsImpl(~,x)
```



```
        if ~isnumeric(x)
            error('Input must be numeric');
        end
    end

    function out = stepImpl(obj,in)
        if obj.UseIncrement
            out = in + obj.Increment;
        else
            out = in + 1;
        end
    end
end
end
```

Note All inputs default to variable-size inputs. See “Change Input Complexity or Dimensions” for more information.

See Also

[validateInputsImpl](#) | [validatePropertiesImpl](#) |

Related Examples

- “Define Basic System Objects” on page 13-2

Concepts

- “Methods Timing” on page 13-44
- “Property Set Methods”
- “System Object Input Arguments and ~ in Code Examples” on page 13-47

Initialize Properties and Setup One-Time Calculations

This example shows how to write code to initialize and set up a System object.

In this example, you allocate file resources by opening the file so the System object can write to that file. You do these initialization tasks one time during setup, rather than every time you call the step method.

Define Public Properties to Initialize

In this example, you define the public `Filename` property and specify the value of that property as the nontunable string, `default.bin`. Users cannot change *nontunable* properties after the `setup` method has been called. Refer to the `Methods Timing` section for more information.

```
properties (Nontunable)
    Filename = 'default.bin'
end
```

Define Private Properties to Initialize

Users cannot access *private* properties directly, but only through methods of the System object. In this example, you define the `pFileID` property as a private property. You also define this property as *hidden* to indicate it is an internal property that never displays to the user.

```
properties (Hidden,Access=private)
    pFileID;
end
```

Define Setup

You use the `setupImpl` method to perform setup and initialization tasks. You should include code in the `setupImpl` method that you want to execute one time only. The `setupImpl` method is called once during the first call to the `step` method. In this example, you allocate file resources by opening the file for writing binary data.

```
methods
    function setupImpl(obj,data)
        obj.pFileID = fopen(obj.Filename,'wb');
```

```

        if obj.pFileID < 0
            error('Opening the file failed');
        end
    end
end
end

```

Although not part of setup, you should close files when your code is done using them. You use the `releaseImpl` method to release resources.

Complete Class Definition File with Initialization and Setup

```

classdef MyFile < matlab.System
%MyFile write numbers to a file

    % These properties are nontunable. They cannot be changed
    % after the setup or step method has been called.
    properties (Nontunable)
        Filename = 'default.bin' % the name of the file to create
    end

    % These properties are private. Customers can only access
    % these properties through methods on this object
    properties (Hidden,Access=private)
        pFileID; % The identifier of the file to open
    end

    methods (Access=protected)
        % In setup allocate any resources, which in this case
        % means opening the file.
        function setupImpl(obj,data)
            obj.pFileID = fopen(obj.Filename,'wb');
            if obj.pFileID < 0
                error('Opening the file failed');
            end
        end
    end

    % This System object writes the input to the file.
    function stepImpl(obj,data)
        fwrite(obj.pFileID,data);
    end
end

```

```
        % Use release to close the file to prevent the
        % file handle from being left open.
        function releaseImpl(obj)
            fclose(obj.pFileID);
        end

        % You indicate that no outputs are provided by returning
        % zero from getNumOutputsImpl
        function numOutputs = getNumOutputsImpl(-)
            numOutputs = 0;
        end
    end
end
```

See Also

setupImpl | releaseImpl | stepImpl |

Related Examples

- “Release System Object Resources” on page 13-29
- “Define Property Attributes” on page 13-18

Concepts

- “Methods Timing” on page 13-44

Set Property Values at Construction Time

This example shows how to define a System object constructor and allow it to accept name-value property pairs as input.

Set Properties to Use Name-Value Pair Input

Define the System object constructor, which is a method that has the same name as the class (MyFile in this example). Within that method, you use the `setProperties` method to make all public properties available for input when the user constructs the object. `nargin` is a MATLAB function that determines the number of input arguments. `varargin` indicates all of the object's public properties.

```
methods
    function obj = MyFile(varargin)
        setProperties(obj,nargin,varargin{:});
    end
end
```

Complete Class Definition File with Constructor Setup

```
classdef MyFile < matlab.System
%MyFile write numbers to a file

    % These properties are nontunable. They cannot be changed
    % after the setup or step method has been called.
    properties (Nontunable)
        Filename = 'default.bin' % the name of the file to create
        Access = 'wb' % The file access string (write, binary)
    end

    % These properties are private. Customers can only access
    % these properties through methods on this object
    properties (Hidden,Access=private)
        pFileID; % The identifier of the file to open
    end

    methods
        % You call setProperties in the constructor to let
```

```
        % a user specify public properties of object as
        % name-value pairs.
        function obj = MyFile(varargin)
            setProperties(obj,nargin,varargin{:});
        end
    end

    methods (Access=protected)
        % In setup allocate any resources, which in this case is
        % opening the file.
        function setupImpl(obj, ~)
            obj.pFileID = fopen(obj.Filename,obj.Access);
            if obj.pFileID < 0
                error('Opening the file failed');
            end
        end

        % This System object writes the input to the file.
        function stepImpl(obj, data)
            fwrite(obj.pFileID,data);
        end

        % Use release to close the file to prevent the
        % file handle from being left open.
        function releaseImpl(obj)
            fclose(obj.pFileID);
        end

        % You indicate that no outputs are provided by returning
        % zero from getNumOutputsImpl
        function numOutputs = getNumOutputsImpl(~)
            numOutputs = 0;
        end
    end
end
```

See Also

narginsetProperties |

**Related
Examples**

- “Define Property Attributes” on page 13-18
- “Release System Object Resources” on page 13-29

Reset Algorithm State

This example shows how to reset an object state.

Reset Counter to Zero

pCount is an internal counter property of the System object obj. The user calls the reset method, which calls the resetImpl method. In this example, pCount resets to 0.

Note When resetting an object's state, make sure you reset the size, complexity, and data type correctly.

```
methods (Access=protected)
    function resetImpl(obj)
        obj.pCount = 0;
    end
end
```

Complete Class Definition File with State Reset

```
classdef Counter < matlab.System
%Counter System object that increments a counter

    properties(Access=private)
        pCount
    end

    methods (Access=protected)
        % In step, increment the counter and return
        % its value as an output
        function c = stepImpl(obj)
            obj.pCount = obj.pCount + 1;
            c = obj.pCount;
        end

        % Reset the counter to zero.
        function resetImpl(obj)
```



```
        obj.pCount = 0;
    end

    % The step method takes no inputs
    function numIn = getNumInputsImpl(~)
        numIn = 0;
    end
end
end
end
```

See “Methods Timing” on page 13-44 for more information.

See Also `resetImpl` |

Concepts

- “Methods Timing” on page 13-44

Define Property Attributes

This example shows how to specify property attributes.

Property attributes, which add details to a property, provide a layer of control to your properties. In addition to the MATLAB property attributes, System objects can use these three additional attributes—`nontunable`, `logical`, and `positiveInteger`. To specify multiple attributes, separate them with commas.

Specify Property as Nontunable

Use the *nontunable* attribute for a property when the algorithm depends on the value being constant once data processing starts. Defining a property as nontunable may improve the efficiency of your algorithm by removing the need to check for or react to values that change. For code generation, defining a property as nontunable allows the memory associated with that property to be optimized. You should define all properties that affect the number of input or output ports as nontunable.

System object users cannot change nontunable properties after the `setup` or `step` method has been called. In this example, you define the `InitialValue` property, and set its value to 0.

```
properties (Nontunable)
    InitialValue = 0;
end
```

Specify Property as Logical

Logical properties have the value, `true` or `false`. System object users can enter 1 or 0 or any value that can be converted to a logical. The value, however, displays as `true` or `false`. You can use sparse logical values, but they must be scalar values. In this example, the `Increment` property indicates whether to increase the counter. By default, `Increment` is tunable property. The following restrictions apply to a property with the `Logical` attribute,

- Cannot also be `Dependent` or `PositiveInteger`
- Default value must be `true` or `false`. You cannot use 1 or 0 as a default value.

```
properties (Logical)
    Increment = true
end
```

Specify Property as Positive Integer

In this example, the private property `pCount` is constrained to accept only real, positive integers. You cannot use sparse values. The following restriction applies to a property with the `PositiveInteger` attribute,

- Cannot also be `Dependent` or `Logical`

```
properties (PositiveInteger)
    Count
end
```

Specify Property as DiscreteState

If your algorithm uses properties that hold state, you can assign those properties the `DiscreteState` attribute. Properties with this attribute display their state values when users call `getDiscreteStateImpl` via the `getDiscreteState` method. The following restrictions apply to a property with the `DiscreteState` attribute,

- Numeric, logical, or `fi` value, but not a scaled double `fi` value
- Does not have any of these attributes: `Nontunable`, `Dependent`, `Abstract`, `Constant`, or `Transient`.
- No default value
- Not publicly settable
- `GetAccess=Public` by default
- Value set only using the `setupImpl` method or when the `System` object is locked during `resetImpl` or `stepImpl`

In this example, you define the `Count` property.

```
properties (DiscreteState)
    Count;
```

```
end
```

Complete Class Definition File with Property Attributes

```
classdef Counter < matlab.System
%Counter Increment a counter starting at an initial value

    % These properties are nontunable. They cannot be changed
    % after the setup or step method has been called.
    properties (Nontunable)
        % The initial value of the counter
        InitialValue = 0
    end

    properties (Logical)
        % Whether to increment the counter
        Increment = true
    end

    % Count state variable
    properties (DiscreteState, PositiveInteger)
        Count
    end

    methods (Access=protected)
        % In step, increment the counter and return its value
        % as an output
        function c = stepImpl(obj)
            if obj.Increment
                obj.Count = obj.Count + 1;
            end
            c = obj.Count;
        end
        % Setup the Count state variable
        function setupImpl(obj)
            obj.Count = 0;
        end
        % Reset the counter to zero.
        function resetImpl(obj)
            obj.Count = obj.InitialValue;
        end
    end
end
```

```
        end
        % The step method takes no inputs
        function numIn = getNumInputsImpl(~)
            numIn = 0;
        end
    end
end
```

Concepts

- “Class Attributes”
- “Property Attributes”
- “What You Cannot Change While Your System Is Running”
- “Methods Timing” on page 13-44

Hide Inactive Properties

This example shows how to hide the display of a property that is not active for a particular object configuration.

Hide an inactive property

You use the `isInactivePropertyImpl` method to hide a property from displaying. If the `isInactiveProperty` method returns true to the property you pass in, then that property does not display.

```
methods (Access=protected)
    function flag = isInactivePropertyImpl(obj,propertyName)
        if strcmp(propertyName,'InitialValue')
            flag = obj.UseRandomInitialValue;
        else
            flag = false;
        end
    end
end
```

Complete Class Definition File with Hidden Inactive Property

```
classdef Counter < matlab.System
    %Counter Increment a counter

    % These properties are nontunable. They cannot be changed
    % after the setup or step method has been called.
    properties (Nontunable)
        % Allow the user to set the initial value
        UseRandomInitialValue = true
        InitialValue = 0
    end

    % The private count variable, which is tunable by default
    properties (Access=private)
        pCount
    end

    methods (Access=protected)
```

```
% In step, increment the counter and return its value
% as an output
function c = stepImpl(obj)
    obj.pCount = obj.pCount + 1;
    c = obj.pCount;
end

%Reset the counter to either a random value or the initial
% value.
function resetImpl(obj)
    if obj.UseRandomInitialValue
        obj.pCount = rand();
    else
        obj.pCount = obj.InitialValue;
    end
end

% The step method takes no inputs
function numIn = getNumInputsImpl(~)
    numIn = 0;
end

% This method controls visibility of the object's properties
function flag = isInactivePropertyImpl(obj,propertyName)
    if strcmp(propertyName,'InitialValue')
        flag = obj.UseRandomInitialValue;
    else
        flag = false;
    end
end
end
end
```

See Also [isInactivePropertyImpl](#) |

Limit Property Values to Finite String Set

This example shows how to limit a property to accept only a finite set of string values.

Specify a Set of Valid String Values

String sets use two related properties. You first specify the user-visible property name and default string value. Then, you specify the associated hidden property by appending “Set” to the property name. You must use a capital “S” in “Set.”

In the “Set” property, you specify the valid string values as a cell array of the `matlab.system.Stringset` class. This example uses `Color` and `ColorSet` as the associated properties.

```
properties
    Color = 'blue'
end
```

```
properties (Hidden,Transient)
    ColorSet = matlab.system.StringSet({'red','blue','green'});
end
```

Complete Class Definition File with String Set

```
classdef Whiteboard < matlab.System
    %Whiteboard Draw lines on a figure window
    %
    % This System object illustrates the use of StringSets

    properties
        Color = 'blue'
    end

    properties (Hidden,Transient)
        % Let them choose a color
        ColorSet = matlab.system.StringSet({'red','blue','green'});
    end
```



```

methods(Access = protected)
function stepImpl(obj)
    h = Whiteboard.getWhiteboard();
    plot(h, ...
        randn([2,1]),randn([2,1]), ...
        'Color',obj.Color(1));
end
function releaseImpl(obj)
    cla(Whiteboard.getWhiteboard());
    hold('on');
end
function n = getNumInputsImpl(~)
    n = 0;
end
function n = getNumOutputsImpl(~)
    n = 0;
end
end

methods (Static)
function a = getWhiteboard()
    h = findobj('tag','whiteboard');
    if isempty(h)
        h = figure('tag','whiteboard');
        hold('on');
    end
    a = gca;
end
end
end
end

```

String Set System Object Example

```

%%
% Each call to step draws lines on a whiteboard

%% Construct the System object
hGreenInk = Whiteboard;
hBlueInk = Whiteboard;

```

```
% Change the color
% Note: Press tab after typing the first single quote to
% display all enumerated values.
hGreenInk.Color = 'green';
hBlueInk.Color  = 'blue';

% Take a few steps
for i=1:3
    hGreenInk.step();
    hBlueInk.step();
end

%% Clear the whiteboard
hBlueInk.release();

%% Display System object used in this example
type('Whiteboard.m');
```

See Also `matlab.system.StringSet` |

Process Tuned Properties

This example shows how to specify the action to take when a tunable property value changes during simulation.

The `processTunedPropertiesImpl` method is useful for managing actions to prevent duplication. In many cases, changing one of multiple interdependent properties causes an action. With the `processTunedPropertiesImpl` method, you can control when that action is taken so it is not repeated unnecessarily.

Control When a Lookup Table Is Generated

This example of `processTunedPropertiesImpl` causes the `pLookupTable` to be regenerated when either the `NumNotes` or `MiddleC` property changes.

```
methods (Access = protected)
    function processTunedPropertiesImpl(obj)
        obj.pLookupTable = obj.MiddleC * ...
            (1+log(1:obj.NumNotes)/log(12));
    end
end
```

Complete Class Definition File with Tuned Property Processing

```
classdef TuningFork < matlab.System
    %TuningFork Illustrate the processing of tuned parameters
    %

    properties
        MiddleC = 440
        NumNotes = 12
    end

    properties (Access=private)
        pLookupTable
    end

    methods(Access=protected)
        function resetImpl(obj)
            obj.MiddleC = 440;
        end
    end
end
```

```
        obj.pLookupTable = obj.MiddleC * ...
            (1+log(1:obj.NumNotes)/log(12));
    end

    function hz = stepImpl(obj,noteShift)
        % A noteShift value of 1 corresponds to obj.MiddleC
        hz = obj.pLookupTable(noteShift);
    end

    function processTunedPropertiesImpl(obj)
        % Generate a lookup table of note frequencies
        obj.pLookupTable = obj.MiddleC * ...
            (1+log(1:obj.NumNotes)/log(12));
    end
end
end
end
```

See Also [processTunedPropertiesImpl](#) |

Release System Object Resources

This example shows how to release resources allocated and used by the System object. These resources include allocated memory, files used for reading or writing, etc.

Release Memory by Clearing the Object

This method allows you to clear the axes on the Whiteboard figure window while keeping the figure open.

```
methods
    function releaseImpl(obj)
        cla(Whiteboard.getWhiteboard());
        hold('on');
    end
end
```

Complete Class Definition File with Released Resources

```
classdef Whiteboard < matlab.System
%Whiteboard Draw lines on a figure window
%
% This System object shows the use of StringSets
%
    properties
        Color = 'blue'
    end

    properties (Hidden)
        % Let user choose a color
        ColorSet = matlab.system.StringSet({'red','blue','green'});
    end

    methods(Access=protected)
        function stepImpl(obj)
            h = Whiteboard.getWhiteboard();
            plot(h, ...
                randn([2,1]), randn([2,1]), ...
                'Color',obj.Color(1));
        end
    end
end
```

```
end

function releaseImpl(obj)
    cla(Whiteboard.getWhiteboard());
    hold('on');
end

function n = getNumInputsImpl(~)
    n = 0;
end
function n = getNumOutputsImpl(~)
    n = 0;
end
end

methods (Static)
function a = getWhiteboard()
    h = findobj('tag','whiteboard');
    if isempty(h)
        h = figure('tag','whiteboard');
        hold('on');
    end
    a = gca;
end
end
end
```

See Also `releaseImpl` |

Related Examples

- “Initialize Properties and Setup One-Time Calculations” on page 13-10

Define Composite System Objects

This example shows how to define System objects that include other System objects.

This example defines a filter System object from an FIR System object and an IIR System object.

Store System Objects in Properties

To define a System object from other System objects, store those objects in your class definition file as properties. In this example, FIR and IIR are separate System objects defined in their own class-definition files. You use those two objects to calculate the pFir and pIir property values.

```
properties (Nontunable, Access = private)
    pFir % store the FIR filter
    pIir % store the IIR filter
end

methods
    function obj = Filter(varargin)
        setProperties(obj, nargin, varargin{:});
        obj.pFir = FIR(obj.zero);
        obj.pIir = IIR(obj.pole);
    end
end
```

Complete Class Definition File of Composite System Object

```
classdef Filter < matlab.System
% Filter System object with a single pole and a single zero
%
% This System object illustrates composition by
% composing an instance of itself.
%

    properties (Nontunable)
        zero = 0.01
        pole = 0.5
    end
end
```

```
end

properties (Nontunable,Access=private)
    pZero % store the FIR filter
    pPole % store the IIR filter
end

methods
    function obj = Filter(varargin)
        setProperties(obj,nargin, varargin{:});
        % Create instances of FIR and IIR as
        % private properties
        obj.pZero = Zero(obj.zero);
        obj.pPole = Pole(obj.pole);
    end
end

methods (Access=protected)
    function setupImpl(obj,x)
        setup(obj.pZero,x);
        setup(obj.pPole,x);
    end

    function resetImpl(obj)
        reset(obj.pZero);
        reset(obj.pPole);
    end

    function y = stepImpl(obj,x)
        y = step(obj.pZero,x) + step(obj.pPole,x);
    end

    function releaseImpl(obj)
        release(obj.pZero);
        release(obj.pPole);
    end
end
end
```

Class Definition File for IIR Component of Filter

```
classdef Pole < matlab.System

    properties
        Den = 1
    end

    properties (Access=private)
        tap = 0
    end

    methods
        function obj = Pole(varargin)
            setProperties(obj,nargin,varargin{:},'Den');
        end
    end

    methods (Access=protected)
        function y = stepImpl(obj,x)
            y = x + obj.tap * obj.Den;
            obj.tap = y;
        end
    end

end
```

Class Definition File for FIR Component of Filter

```
classdef Zero < matlab.System

    properties
        Num = 1
    end

    properties (Access=private)
        tap = 0
    end

    methods
        function obj = Zero(varargin)
            setProperties(obj, nargin,varargin{:},'Num');
        end
    end

end
```

```
        end
    end

    methods (Access=protected)
        function y = stepImpl(obj,x)
            y = x + obj.tap * obj.Num;
            obj.tap = x;
        end
    end

end
```

See Also `nargin`

Define Finite Source Objects

This example shows how to define a System object that performs a specific number of steps or specific number of reads from a file.

Use the FiniteSource Class and Specify End of the Source

- 1 Subclass from finite source class.

```
classdef RunTwice < matlab.System & ...
    matlab.system.mixin.FiniteSource
```

- 2 Specify the end of the source with the isDoneImpl method. In this example, the source has two iterations.

```
methods (Access = protected)
    function bDone = isDoneImpl(obj)
        bDone = obj.NumSteps==2
    end
```

Complete Class Definition File with Finite Source

```
classdef RunTwice < matlab.System & ...
    matlab.system.mixin.FiniteSource
    %RunTwice System object that runs exactly two times
    %
    properties (Access=private)
        NumSteps
    end

    methods (Access=protected)
        function resetImpl(obj)
            obj.NumSteps = 0;
        end

        function y = stepImpl(obj)
            if ~obj.isDone()
                obj.NumSteps = obj.NumSteps + 1;
                y = obj.NumSteps;
            else
```

```
        y = 0;
    end
end

function bDone = isDoneImpl(obj)
    bDone = obj.NumSteps==2;
end
end

methods (Access=protected)
    function n = getNumInputsImpl(~)
        n = 0;
    end
    function n = getNumOutputsImpl(~)
        n = 1;
    end
end
end

end
```

See Also `matlab.system.mixin.FiniteSource` |

Concepts

- “What Are Mixin Classes?” on page 13-48
- “Subclassing Multiple Classes”
- “System Object Input Arguments and ~ in Code Examples” on page 13-47

Save System Object

This example shows how to save a System object.

Save System Object and Child Object

Define a `saveObjectImpl` method to specify that more than just public properties should be saved when the user saves a System object. Within this method, use the default `saveObjectImpl@matlab.System` to save public properties to the struct, `s`. Use the `saveObject` method to save child objects. Save protected and dependent properties, and finally, if the object is locked, save the object's state.

```
methods(Access=protected)
    function s = saveObjectImpl(obj)
        s = saveObjectImpl@matlab.System(obj);
        s.child = matlab.System.saveObject(obj.child);
        s.protected = obj.protected;
        s.pdependentprop = obj.pdependentprop;
        if isLocked(obj)
            s.state = obj.state;
        end
    end
end
```

Complete Class Definition File with Save and Load

```
classdef MySaveLoader < matlab.System

    properties (Access=private)
        child
        pdependentprop
    end

    properties (Access=protected)
        protected = rand;
    end

    properties (DiscreteState=true)
        state
    end
end
```

```
end

properties (Dependent)
    dependentprop
end

methods
    function obj = MySaveLoader(varargin)
        obj@matlab.System();
        setProperties(obj, nargin, varargin{:});
    end
end

methods(Access = protected)
    function setupImpl(obj, varargin)
        obj.state = 42;
    end

    function out = stepImpl(obj, in)
        obj.state = in;
        out = obj.state;
    end
end

% Serialization
methods(Access=protected)
    function s = saveObjectImpl(obj)
        % Call the base class method
        s = saveObjectImpl@matlab.System(obj);

        % Save the child System objects
        s.child = matlab.System.saveObject(obj.child);

        % Save the protected & private properties
        s.protected = obj.protected;
        s.pdependentprop = obj.pdependentprop;

        % Save the state only if object locked
        if isLocked(obj)
```

```
        s.state = obj.state;
    end
end

function loadObjectImpl(obj,s,wasLocked)
    % Load child System objects
    obj.child = matlab.System.loadObject(s.child);

    % Load protected and private properties
    obj.protected = s.protected;
    obj.pdependentprop = s.pdependentprop;

    % Load the state only if object locked
    if wasLocked
        obj.state = s.state;
    end

    % Call base class method to load public properties
    loadObjectImpl@matlab.System(obj,s,wasLocked);
end
end
end
```

See Also

[saveObjectImpl](#) | [loadObjectImpl](#) |

Related Examples

- “Load System Object” on page 13-40

Load System Object

This example shows how to load a System object.

Load System Object and Child Object

Define a `loadObjectImpl` method to load a previously saved System object. Within this method, use the `matlab.System.loadObject` to assign the child object struct data to the associated object property. Assign protected and dependent property data to the associated object properties. If the object was locked when it was saved, assign the object's state to the associated property. Load the saved public properties with the `loadObjectImpl` method.

```
methods(Access=protected)
    function loadObjectImpl(obj,s,wasLocked)
        obj.child = matlab.System.loadObject(s.child);
        obj.protected = s.protected;
        obj.pdependentprop = s.pdependentprop;
        if wasLocked
            obj.state = s.state;
        end
        loadObjectImpl@matlab.System(obj,s,wasLocked);
    end
end
end
```

Complete Class Definition File with Save and Load

```
classdef MySaveLoader < matlab.System

    properties (Access=private)
        child
        pdependentprop
    end

    properties (Access=protected)
        protected = rand;
    end

    properties (DiscreteState=true)
```



```
        state
    end

    properties (Dependent)
        dependentprop
    end

    methods
        function obj = MySaveLoader(varargin)
            obj@matlab.System();
            setProperties(obj, nargin, varargin{:});
        end
    end

    methods(Access = protected)
        function setupImpl(obj,varargin)
            obj.state = 42;
        end

        function out = stepImpl(obj,in)
            obj.state = in;
            out = obj.state;
        end
    end

    end

% Serialization
methods(Access=protected)
    function s = saveObjectImpl(obj)
        % Call the base class method
        s = saveObjectImpl@matlab.System(obj);

        % Save the child System objects
        s.child = matlab.System.saveObject(obj.child);

        % Save the protected & private properties
        s.protected = obj.protected;
        s.pdependentprop = obj.pdependentprop;

        % Save the state only if object locked
```

```
        if isLocked(obj)
            s.state = obj.state;
        end
    end

function loadObjectImpl(obj,s,wasLocked)
    % Load child System objects
    obj.child = matlab.System.loadObject(s.child);

    % Load protected and private properties
    obj.protected = s.protected;
    obj.pdependentprop = s.pdependentprop;

    % Load the state only if object locked
    if wasLocked
        obj.state = s.state;
    end

    % Call base class method to load public properties
    loadObjectImpl@matlab.System(obj,s,wasLocked);
end
end
end
```

See Also

[saveObjectImpl](#) | [loadObjectImpl](#) |

Related Examples

- “Save System Object” on page 13-37

Clone System Object

This example shows how to clone a System object.

Clone System Object

You can define your own clone method, which is useful for copying objects without saving their state. The default `cloneImpl` method copies both a System object™ and its current state. If an object is locked, the default `cloneImpl` creates a cloned object that is also locked. An example of when you may want to write your own clone method is for cloning objects that handle resources. These objects cannot allocate resources twice and you would not want to save their states. To write your clone method, use the `saveObject` and `loadObject` methods to perform the clone within the `cloneImpl` method.

```
methods(Access=protected)
    function obj2 = cloneImpl(obj1)
        s = saveObject (obj1);
        obj2 = loadObject(s);
    end
end
```

Complete Class Definition File with Clone

```
classdef PassThrough < matlab.System
    methods (Access=protected)
        function y = stepImpl(~,u)
            y = u;
        end
        function obj2 = cloneImpl(obj1)
            s = matlab.System.saveObject(obj1);
            obj2 = matlab.System.loadObject(s);
        end
    end
end
```

See Also

`cloneImpl` | `saveObjectImpl` | `loadObjectImpl` |

Methods Timing

In this section...
“Setup Method Call Sequence” on page 13-44
“Step Method Call Sequence” on page 13-45
“Reset Method Call Sequence” on page 13-45
“Release Method Call Sequence” on page 13-46

Setup Method Call Sequence

This hierarchy shows the actions performed when you call the `setup` method.

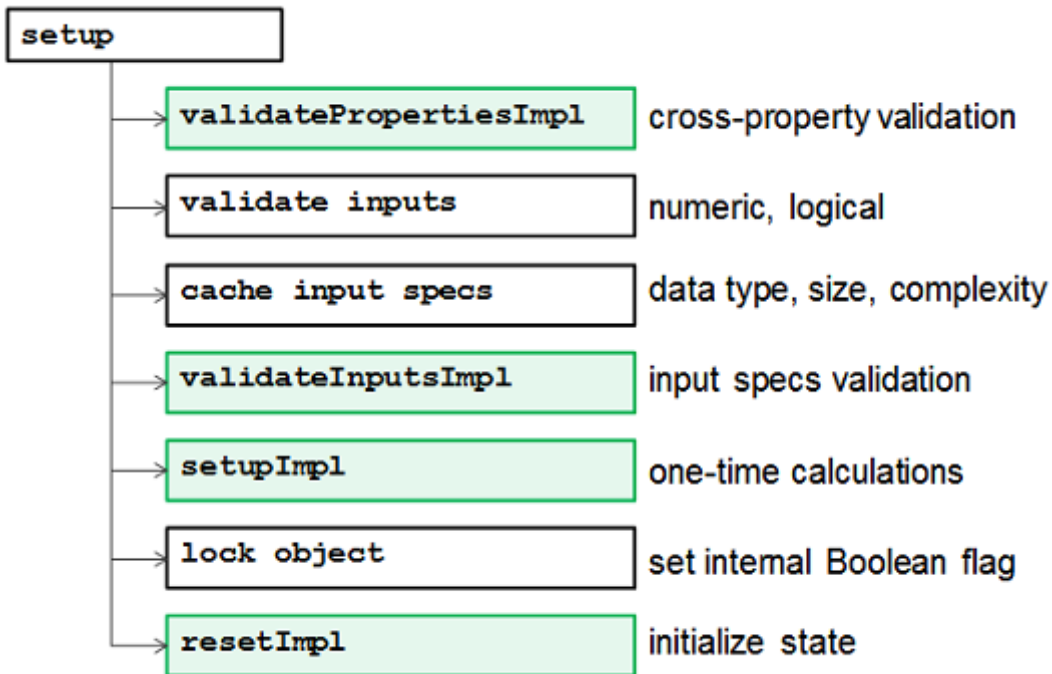

Step Method Call Sequence

This hierarchy shows the actions performed when you call the step method.

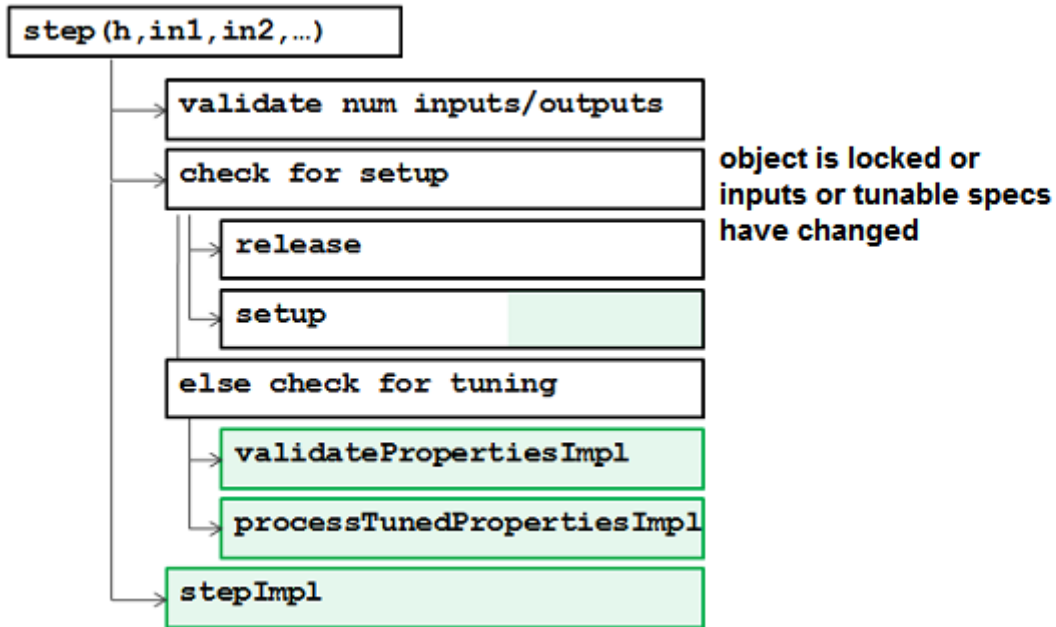

Reset Method Call Sequence

This hierarchy shows the actions performed when you call the reset method.

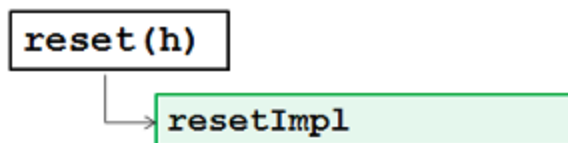

Release Method Call Sequence

This hierarchy shows the actions performed when you call the release method.

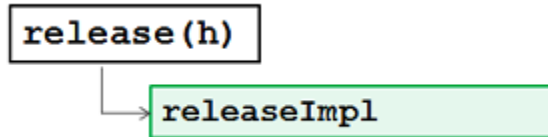

See Also

setupImpl | stepImpl | releaseImpl | resetImpl |

Related Examples

- “Release System Object Resources” on page 13-29
- “Reset Algorithm State” on page 13-16
- “Set Property Values at Construction Time” on page 13-13
- “Define Basic System Objects” on page 13-2

Concepts

- “What Are System Object Methods?”
- “The Step Method”
- “Common Methods”

System Object Input Arguments and ~ in Code Examples

All methods, except static methods, expect the System object handle as the first input argument. You can use any name for your System object handle. In many examples, instead of passing in the object handle, ~ is used to indicate that the object handle is not used in the function. Using ~ instead of an object handle prevents warnings about unused variables.

What Are Mixin Classes?

Mixin classes are partial classes that you can combine in various combinations to form desired behaviors using multiple inheritance. System objects are composed of a base class, `matlab.System` and may include one or more mixin classes. You specify the base class and mixin classes on the first line of your class definition file.

The following mixin classes are available for use with System objects.

- `matlab.system.mixin.CustomIcon` — Defines a block icon for System objects in the MATLAB System block
- `matlab.system.mixin.FiniteSource` — Adds the `isDone` method to System objects that are sources
- `matlab.system.mixin.Nondirect` — Allows the System object, when used in the MATLAB System block, to support nondirect feedthrough by making the runtime callback functions, `output` and `update` available
- `matlab.system.mixin.Propagates` — Enables System objects to operate in the MATLAB System block using the interpreted execution